



**DAN JOHNSON**  
DIRECTOR

DEPARTMENT OF TRANSPORTATION AND DEVELOPMENT  
DEVELOPMENT SERVICES BUILDING  
150 BEAVERCREEK ROAD OREGON CITY, OR 97045

Board of County Commissioners  
Clackamas County

Members of the Board:

Approval of a Contract with S-2 Contractors, Inc, for the  
Salmonberry Drive Paving Project. Total value is \$201,630.00.  
Funding through County Road Fund. County General Funds are not involved.

<b>Purpose/Outcome</b>	The contract will resurface about 0.3 miles of roads. This contract will resurface two local roads: Salmonberry Drive and Columbine Court.
<b>Dollar Amount and Fiscal Impact</b>	Contract value \$201,630.00
<b>Funding Source</b>	County Road fund
<b>Duration</b>	Contract Execution through December 31, 2022.
<b>Previous Board Action/Review</b>	05/10/2022 Discussion item at issues
<b>Strategic Plan Alignment</b>	This project will provide strong infrastructure and ensure safe communities by maintaining the County's existing road infrastructure.
<b>Counsel Review</b>	Counsel Date: April 26, 2022 Counsel Initials: AN
<b>Procurement Review</b>	Was this project processed through Procurement? Yes.
<b>Contact Person</b>	Jon Sparks, Engineering Technician 503-650-3235
<b>Contract No.</b>	5414

**Background:**

The Salmonberry Paving Project will resurface approximately 0.3 miles of local roads. This paving contract will resurface Salmonberry Drive between South End Road and the end of County maintenance as well as Columbine Ct. with asphalt. This will preserve the existing road base preventing a complete reconstruction in the future.

**Procurement Process:**

This project was advertised in accordance with ORS and LCRB Rules on March 8, 2022. Bids were publicly opened on March 31, 2022. The County received four (4) bids: S-2 Contractors, Inc., \$201,630.00, Eagle-Elsner, \$235,000.00, Brix Paving, \$225,930.75, and Knife River, \$221,239.00. After review of the bids, S-2 Contractors, Inc., was determined to be the lowest responsive bidder.

**Recommendation:**

Staff respectfully recommends that the Board approve and sign this public improvements contract with S-2 Contractors, Inc, for the Salmonberry Drive Paving Project.

Sincerely,

*Jon Sparks*

Jon Sparks  
Engineering Technician

Placed on the BCC Agenda \_\_\_\_\_ by Procurement



**CLACKAMAS COUNTY  
PUBLIC IMPROVEMENT CONTRACT**

Contract #5414

This Public Improvement Contract (the "Contract"), is made by and between the Clackamas County, a political subdivision of the State of Oregon, hereinafter called "Owner," and **S-2 Contractors, Inc.**, hereinafter called the "Contractor" (collectively the "Parties"), shall become effective on the date this Contract has been signed by all the Parties and all County approvals have been obtained, whichever is later.

**Project Name: # 2022-26 Salmonberry Drive Paving Project**

**1. Contract Price, Contract Documents and Work.**

The Contractor, in consideration of the sum of **Two Hundred and One Thousand Six Hundred and Thirty Dollars (\$201,630.00)** (the "Contract Price"), to be paid to the Contractor by Owner in the manner and at the time hereinafter provided, and subject to the terms and conditions provided for in the Instructions to Bidders and other Contract Documents (as defined in the project specifications) referenced within the Instructions to Bidders), all of which are incorporated herein by reference, hereby agrees to perform all Work described and reasonably inferred from the Contract Documents. The Contract Price is the amount contemplated by the Base Bid as indicated in the accepted Bid.

Also, the following documents are incorporated by reference in this Contract and made a part hereof:

- Notice of Contract Opportunity
- Supplemental Instructions to Bidders
- Bid Form
- Performance Bond and Payment Bond
- Payroll and Certified Statement Form
- Instructions to Bidders
- Bid Bond
- Public Improvement Contract Form
- Prevailing Wage Rates
- Plans, Specifications and Drawings

The Plans, Specifications and Drawings expressly incorporated by reference into this Contract includes, but is not limited to, the Special Provisions for Salmonberry Paving Project (the "Specifications"), together with the provisions of the Oregon Standard Specifications for Construction (2021) referenced therein.

The Contractor shall comply with the prohibitions set forth in ORS 652.220, compliance of which is a material element of this Contract and failure to comply is a material breach that entitles County to exercise any rights and remedies available under this Contract including, but not limited to, termination for default

**2. Representatives.**

Contractor has named William Shunn as its Authorized Representative to act on its behalf. Owner designates, or shall designate, its Authorized Representative as indicted below (check one):

Unless otherwise specified in the Contract Documents, the Owner designates Vince Hall as its Authorized Representative in the administration of this Contract. The above-named individual shall be the initial point of contact for matters related to Contract performance, payment, authorization, and to carry out the responsibilities of the Owner.

Name of Owner's Authorized Representative shall be submitted by Owner in a separate writing.

**3. Key Persons.**

The Contractor's personnel identified below shall be considered Key Persons and shall not be replaced during the project without the written permission of Owner, which shall not be unreasonably withheld. If the Contractor intends to substitute personnel, a request must be given to Owner at least 30 days prior to the intended time of substitution. When replacements have been approved by Owner, the Contractor shall provide

a transition period of at least 10 working days during which the original and replacement personnel shall be working on the project concurrently. Once a replacement for any of these staff members is authorized, further replacement shall not occur without the written permission of Owner. The Contractor's project staff shall consist of the following personnel:

**Project Executive:** William Shunn shall be the Contractor's project executive, and will provide oversight and guidance throughout the project term.

**Project Manager:** Kerry Rdtich shall be the Contractor's project manager and will participate in all meetings throughout the project term.

**Job Superintendent:** Mike Casey shall be the Contractor's on-site job superintendent throughout the project term.

#### **4. Contract Dates.**

COMMENCEMENT DATE: Upon Issuance of Notice to Proceed ("NTP")

SUBSTANTIAL COMPLETION DATE: September 1, 2022

FINAL COMPLETION DATE: December 31, 2022

Time is of the essence for this Contract. It is imperative that the Work in this Contract reach Substantial Completion and Final Completion by the above specified dates.

#### **5. Insurance Certificates and Required Performance and Payment Bonds.**

5.1 In accordance with Section 00170.70 of the Specifications, Contractor shall furnish proof of the required insurance naming Clackamas County as an additional insured. Insurance certificates may be returned with the signed Contract or may be emailed to [Procurement@clackamas.us](mailto:Procurement@clackamas.us).

5.2 Primary Coverage: Insurance carried by Contractor under the Contract shall be the primary coverage. The coverages indicated are minimums unless otherwise specified in the Contract Documents.

5.2.1 Workers' Compensation: All employers, including Contractor, that employ subject workers who work under the Contract in the State of Oregon shall comply with ORS 656.017 and provide the required Workers' Compensation coverage, unless such employers are exempt under ORS 656.126. This shall include Employer's Liability Insurance with coverage limits of not less than the minimum amount required by statute for each accident. Contractors who perform the Work without the assistance or labor of any employee need not obtain such coverage if the Contractor certifies so in writing. Contractor shall ensure that each of its Subcontractors complies with these requirements. The Contractor shall require proof of such Workers' Compensation coverage by receiving and keeping on file a certificate of insurance from each Subcontractor or anyone else directly employed by either the Contractor or its Subcontractors.

5.3 Builder's Risk Insurance: During the term of the Contract, for new construction the Contractor shall obtain and keep in effect Builder's Risk insurance on an all risk forms, including earthquake and flood, for an amount equal to the full amount of the Contract, plus any changes in values due to modifications, Change Orders and loss of materials added. Such Builder's Risk shall include, in addition to earthquake and flood, theft, vandalism, mischief, collapse, transit, debris removal, and architect's fees "soft costs" associated with delay of Project due to insured peril. Any deductible shall not exceed \$50,000 for each loss, except the earthquake and flood deductible which shall not exceed 2 percent of each loss or \$50,000, whichever is greater. The deductible shall be paid by Contractor. The policy will include as loss payees Owner, the Contractor and its Subcontractors as their interests may appear.

5.4 Builder's Risk Installation Floater: For Work other than new construction, Contractor shall obtain and keep in effect during the term of the Contract, a Builder's Risk Installation Floater for coverage of the Contractor's labor, materials and equipment to be used for completion of the Work performed under the Contract. The minimum amount of coverage to be carried shall be equal to the full amount of the Contract. The policy will include as loss payees Owner, the Contractor and its Subcontractors as their interests may appear. Owner may waive this requirement at its sole and absolute discretion.

5.4.1 Such insurance shall be maintained until Owner has occupied the facility.

5.4.2 A loss insured under the Builder's Risk insurance shall be adjusted by the Owner and made payable to the Owner as loss payee. The Contractor shall pay Subcontractors their just shares of insurance proceeds received by the Contractor, and by appropriate agreements, written where legally required for validity, shall require Subcontractors to make payments to their Sub-subcontractors in similar manner. The Owner shall have power to adjust and settle a loss with insurers.

5.5 "Tail" Coverage: If any of the required liability insurance is arranged on a "claims made" basis, "tail" coverage will be required at the completion of the Contract for a duration of 36 months or the maximum time period available in the marketplace if less than 36 months. Contractor shall furnish certification of "tail" coverage as described or continuous "claims made" liability coverage for 36 months following Final Completion. Continuous "claims made" coverage will be acceptable in lieu of "tail" coverage, provided its retroactive date is on or before the effective date of the Contract. Owner's receipt of the policy endorsement evidencing such coverage shall be a condition precedent to Owner's obligation to make final payment and to Owner's final acceptance of Work or services and related warranty (if any).

5.6 Notice of Cancellation or Change: If the Contractor receives a non-renewal or cancellation notice from an insurance carrier affording coverage required herein, or receives notice that coverage no longer complies with the insurance requirements herein, Contractor agrees to notify Owner by fax within five (5) business days with a copy of the non-renewal or cancellation notice, or written specifics as to which coverage is no longer in compliance. When notified by Owner, the Contractor agrees to stop Work pursuant to the Contract at Contractor's expense, unless all required insurance remain in effect. Any failure to comply with the reporting provisions of this insurance, except for the potential exhaustion of aggregate limits, shall not affect the coverages provided to the Owner and its institutions, divisions, officers, and employees.

Owner shall have the right, but not the obligation, of prohibiting Contractor from entering the Project Site until a new certificate(s) of insurance is provided to Owner evidencing the replacement coverage. The Contractor agrees that Owner reserves the right to withhold payment to Contractor until evidence of reinstated or replacement coverage is provided to Owner.

5.7 Before execution of the Contract, the Contractor shall file with the Construction Contractors Board, and maintain in full force and effect, the separate public works bond required by Oregon Revised Statutes, Chapter 279C.830 and 279C.836, unless otherwise exempt under those provisions. The Contractor shall also include in every subcontract a provision requiring the Subcontractor to have a public works bond filed with the Construction Contractors Board before starting Work, unless otherwise exempt, and shall verify that the Subcontractor has filed a public works bond before permitting any Subcontractor to start Work.

5.8 When the Contract Price is \$50,000 or more, the Contractor shall furnish and maintain in effect at all times during the Contract Period a performance bond in a sum equal to the Contract Price and a separate payment bond also in a sum equal to the Contract Price. Contractor shall furnish such bonds even if the Contract Price is less than the above thresholds if otherwise required by the Contract Documents.

5.9 Bond forms furnished by the Owner and notarized by Contractor's surety company authorized to do business in Oregon are the only acceptable forms of performance and payment security, unless otherwise specified in the Contract Documents.

## **6. Responsibility for Damages/Indemnity.**

6.1 Contractor shall be responsible for all damage to property, injury to persons, and loss, expense, inconvenience, and delay that may be caused by, or result from, the carrying out of the Work to be done under the Contract, or from any act, omission or neglect of the Contractor, its Subcontractors, employees, guests, visitors, invitees and agents.

6.2 To the fullest extent permitted by law, Contractor shall indemnify, defend (with counsel approved by Owner) and hold harmless the Owner and its elected officials, officers, directors, agents, and employees (collectively "Indemnitees") from and against all liabilities, damages, losses, claims, expenses, demands and actions of any nature whatsoever which arise out of, result from or are related to: (a) any damage, injury, loss, expense, inconvenience or delay described in this Section 6.1; (b) any accident or occurrence which happens or is alleged to have happened in or about the Project Site or any place where the Work is being performed, or in the vicinity of either, at any time prior to the time the Work is fully completed in all respects; (c) any failure of the Contractor to observe or perform any duty or obligation under the Contract Documents which is to be observed or performed by the Contractor, or any breach of any agreement, representation or warranty of the Contractor contained in the Contract Documents or in any subcontract; (d) the negligent acts or omissions of the Contractor, a Subcontractor or anyone directly or indirectly employed by them or any one of them or anyone for whose acts they may be liable, regardless of whether or not such claim, damage, loss or expense is caused in part by a party indemnified hereunder (except to the extent otherwise void under ORS 30.140); and (e) any lien filed upon the Project or bond claim in connection with the Work. Such obligation shall not be construed to negate, abridge, or reduce other rights or obligations of indemnity which would otherwise exist as to a party or person described in this Section 6.2.

6.3 In claims against any person or entity indemnified under Section 6.2 by an employee of the Contractor, a Subcontractor, anyone directly or indirectly employed by them or anyone for whose acts they may be liable, the indemnification obligation under Section 6.2 shall not be limited on amount or type of damages, compensation or benefits payable by or for the Contractor or a Subcontractor under workers' compensation acts, disability benefit acts or other employee benefit acts.

## **7. Tax Compliance.**

Contractor must, throughout the duration of this Contract and any extensions, comply with all tax laws of this state and all applicable tax laws of any political subdivision of this state. Any violation of this section shall constitute a material breach of this Contract. Further, any violation of Contractor's warranty in this Contract that Contractor has complied with the tax laws of this state and the applicable tax laws of any political subdivision of this state also shall constitute a material breach of this Contract. Any violation shall entitle County to terminate this Contract, to pursue and recover any and all damages that arise from the breach and the termination of this Contract, and to pursue any or all of the remedies available under this Contract, at law, or in equity, including but not limited to: (A) Termination of this Contract, in whole or in part; (B) Exercise of the right of setoff, and withholding of amounts otherwise due and owing to Contractor, in an amount equal to County's setoff right, without penalty; and (C) Initiation of an action or proceeding for damages, specific performance, declaratory or injunctive relief. County shall be entitled to recover any and all damages suffered as the result of Contractor's breach of this Contract, including but not limited to direct, indirect, incidental and consequential damages, costs of cure, and costs incurred in securing replacement performance. These remedies are cumulative to the extent the remedies are not inconsistent, and County may pursue any remedy or remedies singly, collectively, successively, or in any order whatsoever.

The Contractor represents and warrants that, for a period of no fewer than six calendar years preceding the effective date of this Contract, has faithfully complied with: (A) All tax laws of this state, including but not

limited to ORS 305.620 and ORS chapters 316, 317, and 318; (B) Any tax provisions imposed by a political subdivision of this state that applied to Contractor, to Contractor's property, operations, receipts, or income, or to Contractor's performance of or compensation for any work performed by Contractor; (C) Any tax provisions imposed by a political subdivision of this state that applied to Contractor, or to goods, services, or property, whether tangible or intangible, provided by Contractor; and (D) Any rules, regulations, charter provisions, or ordinances that implemented or enforced any of the foregoing tax laws or provisions.

### **8. Confidential Information.**

Contractor acknowledges that it and its employees or agents may, in the course of performing their responsibilities under this Contract, be exposed to or acquire information that is confidential to Owner. Any and all information of any form obtained by Contractor or its employees or agents in the performance of this Contract shall be deemed confidential information of Owner ("Confidential Information"). Contractor agrees to hold Confidential Information in strict confidence, using at least the same degree of care that Contractor uses in maintaining the confidentiality of its own confidential information, and not to copy, reproduce, sell, assign, license, market, transfer or otherwise dispose of, give, or disclose Confidential Information to third parties or use Confidential Information for any purpose unless specifically authorized in writing under this Contract.

### **9. Counterparts.**

This Contract may be executed in several counterparts, all of which when taken together shall constitute an agreement binding on all Parties, notwithstanding that all Parties are not signatories to the same counterpart. Each copy of the Contract so executed shall constitute an original.

### **10. Integration.**

All provisions of state law required to be part of this Contract, whether listed in the General or Special Conditions or otherwise, are hereby integrated and adopted herein. Contractor acknowledges the obligations thereunder and that failure to comply with such terms is a material breach of this Contract.

The Contract Documents constitute the entire agreement between the parties. There are no other understandings, agreements or representations, oral or written, not specified herein regarding this Contract. Contractor, by the signature below of its authorized representative, hereby acknowledges that it has read this Contract, understands it, and agrees to be bound by its terms and conditions.

### **11. Liquidated Damages**

The Contractor acknowledges that the Owner will sustain damages as a result of the Contractor's failure to substantially complete the Project in accordance with the Contract Documents. These damages may include, but are not limited to delays in completion, use of the Project, and costs associated with Contract administration and use of temporary facilities.

- 11.1 Liquidated Damages shall be as follows if the actual Substantial Completion exceeds the required date of Substantial Completion:
  - 11.1.1. \$ 600.00 per Calendar day past the Substantial Completion date as identified in section 00180.85 (b) and 00180.85 (c).

**12. Compliance with Applicable Law.** Contractor shall comply with all federal, state, county, and local laws, ordinances, and regulations applicable to the Work to be done under this Contract including, but not limited to, compliance with the prohibitions set forth in ORS 652.220, compliance of which is a material element of this Contract and failure to comply is a material breach that entitles County to exercise any rights and remedies available under this Contract including, but not limited to, termination for default.

**13. Responsibility for Taxes.** Contractor is solely responsible for payment of any federal, state, or local taxes required as a result of the Contract or the Work including, but not limited, to payment of the corporate activity

tax imposed under enrolled HB 3427 (2019 Oregon regular legislative session). Contractor may not include its federal, state, or local tax obligations as part of the cost to perform the Work.

**14. Escrow and Retainage.** If retainage is withheld, unless the Contractor requests and the Owner accepts a form of retainage permitted under ORS 279C.560, the Owner will deposit the retainage in an interest-bearing escrow account as required by ORS 279C.570(2). The Contractor shall execute such documentation and instructions respecting the interest-bearing escrow account as the Owner may require to protect its interests, including but not limited to a provision that no funds may be paid from the account to anyone without the Owner's advance written authorization.

**15. No Attorney Fees.** In the event any arbitration, action or proceeding, including any bankruptcy proceeding, is instituted to enforce any term of this Contract, each party shall be responsible for its own attorneys' fees and expenses.

**In witness whereof,** Clackamas County executes this Contract and the Contractor does execute the same as of the day and year first above written.

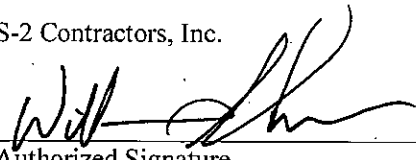
Contractor DATA:  
**S-2 Contractors, Inc**  
**6860 S Anderson Road**  
**Aurora, Oregon 97002**

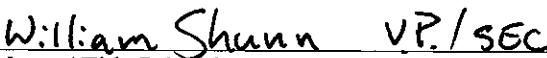
Contractor CCB # 67253 Expiration Date: 6/11/23  
Oregon Business Registry # 183399-86 Entity Type: DBC State of Formation: Oregon

*Payment information will be reported to the IRS under the name and taxpayer ID# provided by the Contractor. Information must be provided prior to contract approval. Information not matching IRS records could subject Contractor to 28 percent backup withholding.*


S-2 Contractors, Inc.

Clackamas County

  
\_\_\_\_\_  
Authorized Signature Date Chair Date

 VP./SEC.  
\_\_\_\_\_  
Name / Title Printed Recording Secretary

APPROVED AS TO FORM

  
\_\_\_\_\_  
County Counsel Date

04/19/2022





**CLACKAMAS COUNTY  
PUBLIC IMPROVEMENT CONTRACT OPPORTUNITY**

Table of Contents

**Section B-1**.....Notice of Public Improvement Contract Opportunity

**Section B-2**.....Instructions to Bidders

**Section B-3**.....Supplemental Instructions to Bidders

**Section B-4**.....Bid Bond

**Section B-5**.....Bid Form

**Section B-6**.....Public Improvement Contract

**Section B-7**.....Performance Bond

**Section B-8**..... Payment Bond

**Section B-9**..... Project Information, Plans, Specifications and Drawings



CLACKAMAS COUNTY  
NOTICE OF PUBLIC IMPROVEMENT CONTRACT OPPORTUNITY

INVITATION TO BID #2022-26  
Salmonberry Drive Paving Project  
March 8, 2022

Clackamas County ("County") through its Board of County Commissioners is accepting sealed bids for the **Salmonberry Drive Paving Project** until **March 31 2022, 2:00 PM**, Pacific Time, ("Bid Closing") at the following location:

**DELIVER BIDS TO:** Clackamas County Procurement Division via email to [procurement@clackamas.us](mailto:procurement@clackamas.us).

Bidding Documents can be downloaded from the state of Oregon procurement website ("OregonBuys") at the following address: <https://oregonbuys.gov/bsv/view/login/login.xhtml>, Document No.S-C01010-00002358.

Prospective Bidders will need to sign in to download the information and that information will be accumulated for a Plan Holder's List. Prospective Bidders are responsible for obtaining any Addenda from Website listed above.

Engineers Estimate: \$200,000.00

Contact Information

Procurement Process and Technical Questions: Tralee Whitley at [TWhitley@clackamas.us](mailto:TWhitley@clackamas.us)

Bids will be opened and publicly read aloud at the above Delivery address after the Bid Closing. Bid results will also be posted to the OregonBuys listing shortly after the opening.

To be eligible for award under this Invitation to Bid, bidders (prime contractors) must submit a prequalification application (either ODOT or County) to the County at least two business days prior to the Bid Closing. County will reject bids from bidders who are not prequalified for the class of work indicated prior to the Bid Closing. **Bidders must be prequalified in Asphalt Concrete Paving (ACP), and Temporary Traffic Control (TTC)**

State Prevailing Wage

Prevailing Wage Rates requirements apply to this Project because the maximum compensation for all Owner-contracted Work is more than \$50,000. Contractor and all subcontractors shall comply with the provisions of ORS 279C.800 through 279C.870, relative to Prevailing Wage Rates. The Bureau of Labor and Industries (BOLI) wage rates and requirements set forth in the following BOLI booklet (and any listed amendments to that booklet), which are incorporated herein by reference, apply to the Work authorized under this Agreement:

PREVAILING WAGE RATES for Public Works Contracts in Oregon, January 1, 2022, which can be downloaded at the following web address:

[http://www.oregon.gov/boli/WHD/PWR/Pages/pwr\\_state.aspx](http://www.oregon.gov/boli/WHD/PWR/Pages/pwr_state.aspx) The Work will take place in Clackamas County, Oregon.

Clackamas County encourages bids from Minority, Women, and Emerging Small Businesses.



## CLACKAMAS COUNTY PUBLIC IMPROVEMENT CONTRACT

### INSTRUCTIONS TO BIDDERS

Clackamas County Local Contract Review Board Rules (“LCRB Rules”) govern this procurement process. LCRB Rules may be found at: <http://www.clackamas.us/code/documents/appendixc.pdf>. The Instructions to Bidders is applicable to the procurement process for Clackamas County, or any component unit thereof identified on the Notice of Public Improvement Contract Opportunity, herein after referred to as the “Owner.”

#### **Article 1. Scope of Work**

The work contemplated under this contract with the Owner, includes all labor, materials, transportation, equipment and services necessary for, and reasonably incidental to, the completion of all construction work in connection with the project described in the Project Manual which includes, but is not necessarily limited to, the Notice of Public Improvement Contract Opportunity, Instructions to Bidders, Supplemental Instructions to Bidders, Bid Form, Bid Bond, Public Improvement Contract Form, Performance Bond, Payment Bond, and Plans, Specifications and Drawings.

#### **Article 2. Examination of Site and Conditions**

Before making a Bid, the Bidder shall examine the site of the work and ascertain all the physical conditions in relation thereto. The Bidder shall also make a careful examination of the Project Manual including the plans, specifications, and drawings and other contract documents, and shall be fully informed as to the quality and quantity of materials and the sources of supply of the materials. Failure to take these steps will not release the successful Bidder from entering into the contract nor excuse the Bidder from performing the work in strict accordance with the terms of the contract at the price established by the Bid.

The Owner will not be responsible for any loss or for any unanticipated costs, which may be suffered by the successful Bidder, as a result of such

Bidder's failure to be fully informed in advance with regard to all conditions pertaining to the work and the character of the work required, including site conditions. No statement made by an elected official, officer, agent, or employee of the Owner in relation to the physical or other conditions pertaining to the site of the work will be binding on the Owner, unless covered by the Project Manual or an Addendum.

#### **Article 3. Interpretation of Project Manual and Approval of Materials Equal to Those Provided in the Specifications**

If any Bidder contemplating submitting a Bid for the proposed contract is in doubt as to the true meaning of any part of the plans, specifications or forms of contract documents, or detects discrepancies or omissions, such Bidder may submit to the Architect (read "Engineer" throughout in lieu of Architect as appropriate) a written request for an interpretation thereof at least ten (10) calendar days prior to the date set for the Bid Closing.

When a prospective Bidder seeks approval of a particular manufacturer's material, process or item of equal value, utility or merit other than that designated by the Architect in the Project Manual, the Bidder may submit to the Architect a written request for approval of such substitute at least ten (10) calendar days prior to the date set for the Bid Closing. The prospective Bidder submitting the request will be responsible for its prompt delivery.

Requests of approval for a substitution from that specified shall be accompanied by samples, records of performance, certified copies of tests by impartial and recognized laboratories, and such other information as the Architect may request.

To establish a basis of quality, certain processes, types of machinery and equipment or kinds of materials may be specified in the Project Manual either by description of process or by designating a

manufacturer by name and referring to a brand or product designation or by specifying a kind of material. Whenever a process is designated or a manufacturer's name, brand or item designation is given, or whenever a process or material covered by patent is designated or described, it shall be understood that the words "or approved equal" follow such name, designation or description, whether in fact they do so or not.

Any interpretation of the Project Manual or approval of manufacturer's material will be made only by an Addendum duly issued. All Addenda will be posted to the OregonBuys listing and will become a part of the Project Manual. The Owner will not be responsible for any other explanation or interpretation of the Project Manual nor for any other approval of a particular manufacturer's process or item for any Bidder.

When the Architect approves a substitution by Addendum, it is with the understanding that the Contractor guarantees the substituted article or material to be equal or better than the one specified.

#### **Article 4. Security to Be Furnished by Each Bidder**

Each Bid must be accompanied by either 1) a cashier's check or a certified check drawn on a bank authorized to do business in the State of Oregon, or 2) a Bid bond described hereinafter, executed in favor of the Owner, for an amount equal to ten percent (10%) of the total amount Bid as a guarantee that, if awarded the contract, the Bidder will execute the contract and provide a performance bond and payment bond as required. The successful Bidder's check or Bid bond will be retained until the Bidder has entered into a contract satisfactory to Owner and furnished a one hundred percent (100%) performance bond and one hundred percent (100%) payment bond. The Owner reserves the right to hold the Bid security as described in Article 10 hereof. Should the successful Bidder fail to execute and deliver the contract as provided for in Article 12 hereof, including a satisfactory performance bond and payment bond within twenty (20) calendar days after the Bid has been accepted by the Owner, then the contract award made to such Bidder may be considered canceled and the Bid security may be

forfeited as liquidated damages at the option of the Owner. The date of the acceptance of the Bid and the award of the contract as contemplated by the Project Manual shall mean the date of acceptance specified in the Notice of Intent to Award.

#### **Article 5. Execution of Bid Bond**

Should the Bidder elect to utilize a Bid bond as described in Article 4 in order to satisfy the Bid security requirements, such form must be completed in the following manner:

- A. Bid bonds must be executed on the County forms, which will be provided to all prospective Bidders by the Owner.
- B. The Bid bond shall be executed on behalf of a bonding company licensed to do business in the State of Oregon.
- C. In the case of a sole individual, the bond need only be executed as principal by the sole individual. In the case of a partnership, the bond must be executed by at least one of the partners. In the case of a corporation, the bond must be executed by stating the official name of the corporation under which is placed the signature of an officer authorized to sign on behalf of the corporation followed by such person's official capacity, such as president, etc. The corporation seal should then be affixed to the bond.
- D. The name of the surety must be stated in the execution over the signature of its duly authorized attorney-in-fact and accompanied by the seal of the surety corporation.

#### **Article 6. Execution of the Bid Form**

Each Bid shall be made in accordance with: (i) the sample Bid Form accompanying these instructions; (ii) the appropriate signatures for a sole individual, partnership, corporation or limited liability corporation shall be added as noted in Article 5C above; (iii) numbers pertaining to base Bids shall be stated both in writing and in figures; and (iv) the Bidder's address shall be typed or printed.

The Bid Form relates to Bids on a specific Project

Manual. Only the amounts and information asked for on the Bid Form furnished will be considered as the Bid. Each Bidder shall Bid upon the work exactly as specified and provided in the Bid Form. The Bidder shall include in the Bid a sum to cover the cost of all items contemplated by the Contract. The Bidder shall Bid upon all alternates that may be indicated on the Bid Form. When Bidding on an alternate for which there is no charge, the Bidder shall write the words "No Charge" in the space provided on the Bid Form. If one or more alternates are shown on the Bid Form, the Bidder shall indicate whether each is "add" or "deduct."

#### **Article 7. Prohibition of Alterations to Bid**

Bids that are incomplete, or contain ambiguities or have differing conditions required by the Bidder, including requested changes or exceptions to the Public Improvement Contract form or other portions of the Project Manual, may be rejected in Owner's sole and absolute discretion.

#### **Article 8. Submission of Bid**

Each Bid shall be sealed in an envelope, properly addressed to the Owner, showing on the outside of the envelope the name of the Bidder and the name of the project. Bids will be received at the time and place stated in the Notice of Public Improvement Contract Opportunity.

#### **Article 9. Bid Closing and Opening of Bids**

All Bids must be received by the Owner at the place and time set for the Bid Closing. Any Bids received after the scheduled Bid Closing time for receipt of Bids will be rejected.

At the time of opening and reading of Bids, each Bid received will be publicly opened and read aloud, irrespective of any irregularities or informalities in such Bids.

Generally, Bid results will be posted to the Procurement Website within a couple hours of the opening.

#### **Article 10. Acceptance or Rejection of Bids by Owner**

Unless all Bids are rejected, the Owner will award a contract based on the lowest responsive Bid from a responsible Bidder. If that Bidder does not execute the contract, it will be awarded to the next lowest responsible Bidder or Bidders in succession.

The Owner reserves the right to reject all Bids and to waive minor informalities. The procedures for contract awards shall be in compliance with the provisions of the LCRB Rules in effect at that time.

The Owner reserves the right to hold the Bid and Bid security of the three lowest Bidders for a period of thirty (30) calendar days from and after the time of Bid opening pending award of the contract. Following award of the contract the Bid security of the three lowest Bidders may be held twenty (20) calendar days pending execution of the contract. All other Bids will be rejected and Bid security will be returned.

In determining the lowest Bidder, the Owner reserves the right to take into consideration any or all authorized base Bids as well as alternates or combinations indicated in the Bid Form.

If no Bid has been accepted within thirty (30) calendar days after the opening of the Bids, each of the three lowest Bidders may withdraw the Bid submitted and request the return of the Bid security.

#### **Article 11. Withdrawal of Bid**

At any time prior to the Bid Closing, a Bidder may withdraw its Bid. This will not preclude the submission of another Bid by such Bidder prior to the time set for the Bid Closing.

After the time set for the Bid Closing, no Bidder will be permitted to withdraw its Bid within the time frames specified in Article 10 for award and execution, except as provided for in that Article.

#### **Article 12. Execution of Contract, Performance Bond and Payment Bond**

The Owner will provide the successful Bidder with contract forms within seven (7) calendar days after

the completion of the award protest period. The Bidder is required to execute the contract forms as provided, including a performance bond and a payment bond from a surety company licensed to do surety business in the State of Oregon, within seven (7) calendar days after receipt of the contract forms. The contract forms shall be delivered to the Owner in the number called for and to the location as instructed by the Owner.

### **Article 13. Recyclable Products**

Contractors will use recyclable products to the maximum extent economically feasible in the performance of the Contract.

### **Article 14. Clarification or Protest of the Solicitation Document or Specifications**

Any request for clarification or protest of the solicitation document or specifications must be submitted in the manner provided for in the applicable section of the LCRB Rules to the Procurement Representative referenced in the Notice of Public Improvement Contract Opportunity.

A protest of the Solicitation Document must be received within seven (7) business days of the issuance of the Bid or within three (3) business days of issuance of an addendum.

Requests for clarification may be submitted no less than five (5) business days prior to the Bid Closing Date.

### **Article 15. Protest of Intent to Award**

Owner will name the apparent successful Bidder in a "Notice of Intent to Award" letter. Identification of the apparent successful Bidder is procedural only and creates no right in the named Bidder to the award of the contract. Competing Bidders will be notified by publication of the Notice of Intent to Award on the Clackamas County Procurement Website of the selection of the apparent successful Bidder(s) and Bidders shall be given seven (7) calendar days from the date on the "Notice of Intent to Award" letter to review the file at the Procurement Division office and file a written protest of award, pursuant to C-

049-0450. Any award protest must be in writing and must be delivered by hand delivery or mail to the Procurement Division Director at:  
Procurement Division, 2051 Kaen Road, Oregon City, OR 97045.

### **Article 16. Disclosure of First-Tier Subcontractors**

Within two (2) working hours after the Bid Closing, all Bidders shall submit to the County a disclosure form identifying any first-tier subcontractors (those entities that would be contracting directly with the prime contractor) that will be furnishing labor and materials on the contract, if awarded, whose subcontract value would be equal to or greater than: (a) Five percent (5%) of the total contract price, but at least \$15,000; or (b) \$350,000, regardless of the percentage of the total contract price.

Disclosures may be submitted with the Bid or may be hand delivered to the Bid Closing address or emailed to [procurement@clackamas.us](mailto:procurement@clackamas.us).



**CLACKAMAS COUNTY  
PUBLIC IMPROVEMENT CONTRACT**

**SUPPLEMENTAL INSTRUCTIONS TO BIDDERS**

**Project Name: # 2022-26 Salmonberry Drive Paving Project**

**The following modify the Clackamas County “Instructions to Bidders” for this Project. Where a portion of the Instructions to Bidders has been modified by these Supplemental Instructions to Bidders, the unaltered portions shall remain in effect.**

1. To be eligible for award under this Invitation to Bid, bidders (prime contractors) must submit a prequalification application (either ODOT or County) to the County at least two business days prior to the Bid Closing. County will reject bids from bidders who are not prequalified for the class of work indicated prior to the Bid Closing. **Bidders must be prequalified in Asphalt Concrete Paving & Oiling (ACP), and Temporary Traffic Control (TTC).**
2. **Email of Bids** - The County is requiring all bids for this project be electronically submitted. Complete Bids (including all attachments) must be received by the closing time and date 2:00 p.m. Pacific Time, **March 31, 2022**. The Bid must be emailed to the following address: [Procurement@clackamas.us](mailto:Procurement@clackamas.us). **The email subject line must read “Bid for #2022-26 Salmonberry Drive Paving Project.”** Upon receiving of the bid, the County will send bidders an email confirmation acknowledging receipt. Bids delayed or lost by email system filtering or failures may be considered at Clackamas County’s sole and absolute discretion.  
Bids will be publicly read aloud via the computer application, Zoom. Bidders will be allowed to video conference or listen by phone to the bid results. The projects Zoom meeting can be accessed via the information below:

**ZOOM LINK**

Join Zoom Meeting

<https://clackamascounty.zoom.us/j/81142442144>

Meeting ID: 811 4244 2144

One tap mobile

+12532158782,,81142442144# US (Tacoma)

+13462487799,,81142442144# US (Houston)

Dial by your location

+1 253 215 8782 US (Tacoma)

+1 346 248 7799 US (Houston)

+1 408 638 0968 US (San Jose)

+1 669 900 6833 US (San Jose)  
+1 312 626 6799 US (Chicago)  
+1 646 876 9923 US (New York)  
+1 301 715 8592 US (Washington DC) Meeting ID: 811 4244 2144 Find  
your local number: <https://clackamascounty.zoom.us/j/kdr1ZyPnOh>

**\*\*The Apparent Low bid results will be posted to the projects OregonBuys listing as soon as possible following the bid opening.**

- 3. Good Faith Effort:** Clackamas County encourages participation in contracts by Historically Underrepresented Businesses. “Historically Underrepresented Businesses” are State of Oregon-certified and self-identified minority, women and emerging small business as well as firms that are certified federally or by another state or entity with substantially similar requirements as the State of Oregon.

Bidders must perform Good Faith Effort (defined below) and submit **Form 1 and Form 2** for the Bidders Bid to be considered responsive. **Form 1 and Form 2** must be submitted within **two (2) hours** after the Closing Date and Time. Form 1 and Form 2 may be submitted by hand delivery to the location the Bid was due or may email the completed Forms to [Procurement@clackamas.us](mailto:Procurement@clackamas.us). “Good Faith Effort” is a requirement of a prime contractor to reach out to at least three Historically Underrepresented Business Subcontractors for each division of work that will be subcontracted out and to complete the required forms. If fewer than three Historically Underrepresented Business Subcontractors are reasonably available for a particular division of work, the Bidder must specifically note the reason for there being fewer than three contacts. The outreach should be performed with sufficient time to give the subcontractors at least 5 calendar days to respond to the opportunity. Form 3, which documents the actual amount of subcontractors on the project, must be submitted with the project final pay application. Compliance with the Good Faith Effort and submission of Forms 1, 2 and 3 is a contractual requirement for final payment.

The sufficiency of the documentation or the performance of Good Faith Effort shall be in the sole and absolute determination of Clackamas County. Only those Bidders that Clackamas County has determined have not sufficiently performed Good Faith Effort shall have protest rights of the determination for such Bidder. No Bidder shall have protest rights of the sufficiency of any other Bidder completing Good Faith Effort.





CLACKAMAS COUNTY
PUBLIC IMPROVEMENT CONTRACT

BID BOND

Project Name: # 2022-26 Salmonberry Drive Paving Project

We, S-2 Contractors, Inc., as "Principal,"
(Name of Principal)

and Western Surety Company, an South Dakota Corporation,
(Name of Surety)

authorized to transact Surety business in Oregon, as "Surety," hereby jointly and severally bind ourselves, our respective heirs, executors, administrators, successors and assigns to pay unto Clackamas County ("Obligee") the sum of (\$ 10% of Bid---

Ten Percent of Total Amount Bid--- dollars.

WHEREAS, the condition of the obligation of this bond is that Principal has submitted its proposal or bid to an agency of the Obligee in response to Obligee's procurement document (No. 2022-26 ) for the project identified above which proposal or bid is made a part of this bond by reference, and Principal is required to furnish bid security in an amount equal to ten (10%) percent of the total amount of the bid pursuant to the procurement document.

NOW, THEREFORE, if the Obligee shall accept the bid of the Principal and the Principal shall enter into a Contract with the Obligee in accordance with the terms of such bid, and give such bond or bonds as may be specified in the bidding or Contract Documents with good and sufficient surety for the faithful performance of such Contract and for the prompt payment of labor and material furnished in the prosecution thereof, or in the event of the failure of the Principal to enter such Contract and give such bond or bonds, if the Principal shall pay to the Obligee the difference not to exceed the penalty hereof between the amount specified in said bid and such larger amount for which the Obligee may in good faith contract with another party to perform the Work covered by said bid, then this obligation shall be null and void, otherwise to remain in full force and effect.

IN WITNESS WHEREOF, we have caused this instrument to be executed and sealed by our duly authorized legal representatives this 31st day of March, 20 22.

Principal: S-2 Contractors, Inc.

Surety: Western Surety Company

By: [Signature]
Signature

By: Gloria Bruning
By: Attorney-In-Fact

President
Official Capacity

Gloria Bruning
Name

Attest: [Signature]
Corporation Secretary

PO Box 2808
Address

Portland, OR 97208
City State Zip

503-224-2500 503-224-9830
Phone Fax



# Western Surety Company

## POWER OF ATTORNEY APPOINTING INDIVIDUAL ATTORNEY-IN-FACT

Know All Men By These Presents, That WESTERN SURETY COMPANY, a South Dakota corporation, is a duly organized and existing corporation having its principal office in the City of Sioux Falls, and State of South Dakota, and that it does by virtue of the signature and seal herein affixed hereby make, constitute and appoint

**Philip O Forker, Vicki Mather, Gloria Bruning, J Patrick Dooney, Richard W Kowalski, Brent Olson, Leticia Romano, Joel Dietzman, Christopher A Reburn, Gail A Price, Justin Cumnock, Andrew Choruby, Casey J Geske, Sterling Drew Roddan, Amanda J Lee, Individually**

of Lake Oswego, OR, its true and lawful Attorney(s)-in-Fact with full power and authority hereby conferred to sign, seal and execute for and on its behalf bonds, undertakings and other obligatory instruments of similar nature

**- In Unlimited Amounts -**

and to bind it thereby as fully and to the same extent as if such instruments were signed by a duly authorized officer of the corporation and all the acts of said Attorney, pursuant to the authority hereby given, are hereby ratified and confirmed.

This Power of Attorney is made and executed pursuant to and by authority of the By-Law printed on the reverse hereof, duly adopted, as indicated, by the shareholders of the corporation.

In Witness Whereof, WESTERN SURETY COMPANY has caused these presents to be signed by its Vice President and its corporate seal to be hereto affixed on this 14th day of December, 2021.



WESTERN SURETY COMPANY

*Paul T. Bruflat*

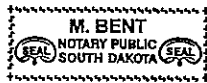
Paul T. Bruflat, Vice President

State of South Dakota }  
County of Minnehaha } ss

On this 14th day of December, 2021, before me personally came Paul T. Bruflat, to me known, who, being by me duly sworn, did depose and say: that he resides in the City of Sioux Falls, State of South Dakota; that he is the Vice President of WESTERN SURETY COMPANY described in and which executed the above instrument; that he knows the seal of said corporation; that the seal affixed to the said instrument is such corporate seal; that it was so affixed pursuant to authority given by the Board of Directors of said corporation and that he signed his name thereto pursuant to like authority, and acknowledges same to be the act and deed of said corporation.

My commission expires

March 2, 2026



*M. Bent*

M. Bent, Notary Public

### CERTIFICATE

I, L. Nelson, Assistant Secretary of WESTERN SURETY COMPANY do hereby certify that the Power of Attorney hereinabove set forth is still in force, and further certify that the By-Law of the corporation printed on the reverse hereof is still in force. In testimony whereof I have hereunto subscribed my name and affixed the seal of the said corporation this 31<sup>st</sup> day of March 2022



WESTERN SURETY COMPANY

*L. Nelson*

L. Nelson, Assistant Secretary



CLACKAMAS COUNTY
PUBLIC IMPROVEMENT CONTRACT

BID FORM

PROJECT: # 2022-26 Salmonberry Drive Paving Project
BID CLOSING: March 31, 2022, 2:00 PM, Pacific Time
BID OPENING: March 31, 2022, 2:05 PM, Pacific Time

FROM: S-2 Contractors Inc.
Bidder's Name (must be full legal name, not ABN/DBA)

TO: Clackamas County
Procurement Division - procurement@clackamas.us

1. Bidder is (check one of the following and insert information requested):

- a. An individual; or
b. A partnership registered under the laws of the State of ...; or
c. A corporation organized under the laws of the State of Oregon; or
d. A limited liability corporation organized under the laws of the State of ...;

and authorized to do business in the State of Oregon hereby proposes to furnish all material and labor and perform all work hereinafter indicated for the above project in strict accordance with the Contract Documents for the Basic Bid as follows:

Two hundred one thousand six hundred thirty Dollars (\$201,630.00)

and the Undersigned agrees to be bound by the following documents:

- Notice of Public Improvement Contract Opportunity
• Instructions to Bidders
• Bid Bond
• Public Improvement Contract Form
• Prevailing Wage Rates
• Plans, Specifications and Drawings
• Supplemental Instructions to Bidders
• Bid Form
• Performance Bond and Payment Bond
• Payroll and Certified Statement Form

• ADDENDA numbered 0 through 0, inclusive (fill in blanks)

2. The Undersigned proposes to add to or deduct from the Base Bid indicated above the items of work relating to the following Alternate(s) as designated in the Specifications: N/A

3. The Undersigned proposes to add to or deduct from the Base Bid indicated above the items or work relating to the following Unit Price(s) as designated in the Specifications, for which any adjustments in the Contract amount will be made in accordance with the project specifications: Provide the attached Bid Schedules with Bid.

4. The work shall be completed within the time stipulated and specified in 00180.50(h) of the Special Provisions for **Salmonberry Paving Project**.
5. Accompanying herewith is Bid Security which is equal to ten percent (10%) of the total amount of the Basic Bid, plus the total sum of Alternatives (if any).
6. The Undersigned agrees, if awarded the Contract, to execute and deliver to Clackamas County, within twenty (20) calendar days after receiving the Contract forms, a Contract Form, and a satisfactory Performance Bond and Payment Bond each in an amount equal to one hundred percent (100% ) of the Contract sum, using forms provided by the Owner. The surety requested to issue the Performance Bond and Payment Bond will be:

Western Surety Company  
 (name of surety company - not insurance agency)

The Undersigned hereby authorizes said surety company to disclose any information to the Owner concerning the Undersigned's ability to supply a Performance Bond and Payment Bond each in the amount of the Contract.

7. The Undersigned further agrees that the Bid Security accompanying the Bid is left in escrow with Clackamas County; that the amount thereof is the measure of liquidated damages which the Owner will sustain by the failure of the Undersigned to execute and deliver the above-named Contract Form, Performance Bond and Payment Bond, each as published, and that if the Undersigned defaults in either executing the Contract Form or providing the Performance Bond and Payment Bond within twenty (20) calendar days after receiving the Contract forms, then the Bid Security shall become the property of the Owner at the Owner's option; but if the Bid is not accepted within thirty (30) calendar days of the time set for the opening of the Bids, or if the Undersigned executes and timely delivers said Contract Form, Performance Bond and Payment Bond, the Bid Security shall be returned.

8. The Undersigned certifies that: (i) This Bid has been arrived at independently and is being submitted without collusion with and without any agreement, understanding, or planned common course of action with any other vendor of materials, supplies, equipment or services described in the invitation to bid designed to limit independent bidding or competition; and (ii) the contents of the Bid have not been communicated by the Undersigned or its employees or agents to any person not an employee or agent of the Undersigned or its surety on any Bond furnished with the Bid and will not be communicated to such person prior to the official opening of the Bid.

9. The undersigned  HAS,  HAS NOT (check one) paid unemployment or income taxes in Oregon within the past 12 months and  DOES,  DOES NOT (check one) a business address in Oregon. The undersigned acknowledges that, if the selected bidder, that the undersigned will have to pay all applicable taxes and register to do business in the State of Oregon before executing the Contract Form.

10. The Undersigned agrees, if awarded a contract, to comply with the provisions of ORS 279C.800 through 279C.870 pertaining to the payment of the prevailing rates of wage.

11. Contractor's CCB registration number is 67253. As a condition to submitting a bid, a Contractor must be registered with the Oregon Construction Contractors Board in accordance with ORS 701.035 to 701.055, and disclose the registration number. Failure to register and disclose the number will make the bid unresponsive and it will be rejected, unless contrary to federal law.

12. The successful Bidder hereby certifies that all subcontractors who will perform construction work as described in ORS 701.005(2) were registered with the Construction Contractors Board in accordance with ORS 701.035 to 701.055 at the time the subcontractor(s) made a bid to work under the contract.

13. The successful Bidder hereby certifies that, in compliance with the Worker's Compensation Law of the State of Oregon, its Worker's Compensation Insurance provider is ~~SAIF Corp~~ SAIF Corp Policy No. 782973, and that Contractor shall submit Certificates of Insurance as required.

14. Contractor's Key Individuals for this project (supply information as applicable):

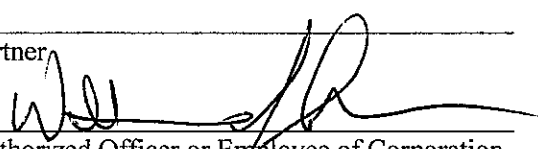
Project Executive: <u>William Shunn</u>	Cell Phone: <u>503-347-0580</u>
Project Manager: <u>Kerry Rditsch</u>	Cell Phone: <u>503-320-2626</u>
Job Superintendent: <u>Mike Casey</u>	Cell Phone: <u>503-349-9378</u>
Project Engineer: _____	Cell Phone: _____

15. The Undersigned certifies that it has not discriminated against minority, women, or emerging small businesses in obtaining any subcontracts for this project.

16. The Undersigned certifies that it has a drug testing program in accordance with ORS 279C.505.

**REMINDER:** Bidder must submit the below First-Tier Subcontractor Disclosure Form.

By signature below, Contractor agrees to be bound by this Bid.

NAME OF FIRM	<u>S-2 Contractors Inc.</u>
ADDRESS	<u>6860 S Anderson Rd</u> <u>Aurora, OR 97002</u>
TELEPHONE NO	<u>503-651-4000</u>
EMAIL	<u>Krobitsch@s2contractorsinc.com</u>
SIGNATURE 1)	_____
	Sole Individual
or 2)	_____
	Partner
or 3)	
	Authorized Officer or Employee of Corporation

\*\*\*\*\* END OF BID \*\*\*\*\*


S SALMONBERRY DRIVE RD# 31062 & S COLUMBINE CT RD# 31063						
Item #	Spec #	Item Description	Unit	Quantity	Unit Price	Amount
<b>TEMPORARY FEATURES AND APPURTENANCES</b>						
101	00197	EXTRA WORK DONE ON FORCE ACCOUNT BASIS	LS	1	\$7,500.00	\$7,500.00
102	00210	MOBILIZATION	LS	1	14,500. <sup>00</sup>	14,500. <sup>00</sup>
103	00210	DOOR HANGERS: PAVING INFORMATION	LS	1	1,000. <sup>00</sup>	1,000. <sup>00</sup>
104	00221	TEMPORARY WORK ZONE TRAFFIC CONTROL, COMPLETE	LS	1	7,000. <sup>00</sup>	7,000. <sup>00</sup>
105	00222	TEMPORARY SIGNS: PROJECT INFORMATION SIGNS	SQFT	30	30. <sup>00</sup>	900. <sup>00</sup>
106	00225	TEMPORARY PAVEMENT BARS	SQFT	20	10. <sup>00</sup>	200. <sup>00</sup>
107	00280	EROSION CONTROL	LS	1	1,000. <sup>00</sup>	1,000. <sup>00</sup>
108	00290	POLLUTION CONTROL PLAN	LS	1	700. <sup>00</sup>	700. <sup>00</sup>
<b>TEMPORARY FEATURES AND APPURTENANCES-SUBTOTAL</b>						<b>32,800.<sup>00</sup></b>
<b>ROADWORK</b>						
109	00310	REMOVAL OF SURFACINGS	SQYD	5,055	5. <sup>00</sup>	25,275. <sup>00</sup>
110	00310	ASPHALT PAVEMENT SAW CUTTING	FOOT	60	10. <sup>00</sup>	600. <sup>00</sup>
<b>ROADWORK-SUBTOTAL</b>						<b>25,875.<sup>00</sup></b>
<b>BASES</b>						
111	00610	RECONDITIONING OF SURFACINGS	SQYD	5,055	1. <sup>00</sup>	5,055. <sup>00</sup>
<b>BASE - SUBTOTAL</b>						<b>5,055.<sup>00</sup></b>
<b>WEARING SURFACES</b>						
112	00744	LEVEL 2, 1/2 INCH ACP	TON	1,200	108. <sup>00</sup>	129,600. <sup>00</sup>
113	00748	12 INCH DEPTH OF SUBGRADE STABILIZATION	SQYD	150	50. <sup>00</sup>	7,500. <sup>00</sup>
<b>WEARING SURFACES - SUBTOTAL</b>						<b>137,100.<sup>00</sup></b>
<b>PERMANENT TRAFFIC CONTROL</b>						
114	00867	PAVEMENT BARS, TYPE B-HS	SQFT	20	40. <sup>00</sup>	800. <sup>00</sup>
<b>PERMANENT TRAFFIC CONTROL-SUBTOTAL</b>						<b>800.<sup>00</sup></b>
<b>TOTAL</b>						<b>201,630.<sup>00</sup></b>

S SALMONBERRY DRIVE RD# 31062 & S COLUMBINE CT RD# 31063

Total Price Two hundred one Thousand six Hundred Thirty Dollars and  
zero Cents

Name of Firm S-2 Contractors, Inc.

Name (Print) William Shinn

Signature  3/31/22  
Date

**FIRST-TIER SUBCONTRACTOR DISCLOSURE FORM**  
**PROJECT: #2022-26 Salmonberry Drive Paving Project**

**BID OPENING: March 31, 2021, 2:00 PM, Pacific Time**

**Failure to submit this Form by the disclosure deadline will result in a nonresponsive bid.**

**INSTRUCTIONS:**

This First-Tier Subcontractor Disclosure Form ("Form") must be submitted and received at the location specified in the Notice of Public Improvement Contract Opportunity on the advertised Bid Closing, and within two working hours after the advertised Bid Closing Time.

The Form may be mailed, hand-delivered or emailed to: Procurement@clackamas.us. It is the responsibility of Bidders to submit this Form and any additional sheets with the Project name clearly marked on the envelope or the subject line of the email.

Subcontractor lists may be submitted with the bid in the same envelope or email at the Bid Closing date and time. Subcontractor lists **MUST** be submitted within **two (2) hours** of the Bid Closing date and time.

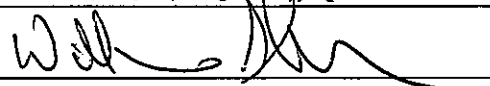
List below the name of each subcontractor that will be furnishing labor, or labor and materials, for which disclosure is required, the category of work that the subcontractor will be performing, and the dollar value of the subcontract. Enter "**NONE**" if the value of the project bid is less than \$100,000 or there are no subcontractors that need to be disclosed. **ATTACH ADDITIONAL SHEETS IF NECESSARY.**

	SUBCONTRACTOR NAME	DOLLAR VALUE	CATEGORY OF WORK
1.	<u>NONE</u>	_____	_____
2.	_____	_____	_____
3.	_____	_____	_____
4.	_____	_____	_____
5.	_____	_____	_____
6.	_____	_____	_____

The above listed first-tier subcontractor(s) are providing labor, or labor and material, with a Dollar Value equal to or greater than:

- a) 5% of the total Contract Price, but at least \$15,000. If the Dollar Value is less than \$15,000 do not list the subcontractor above; or
- b) \$350,000 regardless of the percentage of the total Contract Price.

Firm Name: SE Contractors Inc

Bidder Signature:  Phone # 503-651-4000



**CLACKAMAS COUNTY  
GOOD FAITH EFFORT  
SUBCONTRACTOR AND SELF-PERFORMED WORK LIST  
(FORM 1)**

Prime Contractor Name: *S-Z Contractors, Inc.*

Total Contract Amount:

Project Name: # 2022-26 Salmonberry Drive Paving Project

**PRIME SELF-PERFORMING:** Identify below ALL GFE Divisions of Work (DOW) to be self-performed. Good Faith Efforts are otherwise required.

<u>DOW BIDDER WILL SELF-PERFORM (GFE not required)</u>	
<i>Paving</i>	<i>Trucking</i>
<i>Striping</i>	
<i>Traffic Control</i>	
<i>Excavation</i>	

**PRIME CONTRACTOR SHALL DISCLOSE AND LIST ALL SUBCONTRACTORS**, including those Minority-owned, Woman-owned, and Emerging Small Businesses ("M/W/ESB") that you intend to use on the project. Hand delivery to Procurement, 2051 Kaen Road, Oregon City, OR 97045 or email to [procurement@clackamas.us](mailto:procurement@clackamas.us) within 2 hours of the BID/Quote Closing Date/Time

<b>LIST ALL SUBCONTRACTORS BELOW</b> Use <u>correct legal name</u> of Subcontractor (No Assumed Business Names)	Division of Work (Painting, electrical, landscaping, etc.) List ALL DOW performed by Subcontractors	DOLLAR AMOUNT OF SUBCONTRACT	If Certified or self-reporting MBE/WBE/ESB Subcontractor  Check box <input checked="" type="checkbox"/>		
			MBE	WBE	ESB
Name <i>Brothers Concrete Cutting, Inc.</i> Address <i>1721 Fescue St SE</i> City/St/Zip <i>Albany, OR 97322</i> Phone# <i>541-928-2502</i> OCCB# <i>48661</i>	<i>Sawcutting</i>	<i>\$350.00</i>	<input checked="" type="checkbox"/>	<input type="checkbox"/>	<input type="checkbox"/>
Name Address City/St/Zip Phone# OCCB#			<input type="checkbox"/>	<input type="checkbox"/>	<input type="checkbox"/>
Name Address City/St/Zip Phone# OCCB#			<input type="checkbox"/>	<input type="checkbox"/>	<input type="checkbox"/>
Name Address City/St/Zip Phone# OCCB#			<input type="checkbox"/>	<input type="checkbox"/>	<input type="checkbox"/>

**CLACKAMAS COUNTY  
GOOD FAITH EFFORT  
M/W/ESB CONTACT / BIDS RECEIVED LOG  
(FORM 2)**

Prime Contractor:  
Project: # 2022-26 Salmonberry Drive Paving Project

Prime Contractor must contact or endeavor to contact at least 3 M/W/ESB Subcontractors for each Division of Work. Prime Contractor shall record its contacts with M/W/ESB Subcontractors through use of this log (or equivalent) entering all required information. All columns shall be completed where applicable. Additional forms may be copied if needed.

NAME OF M/W/ESB SUBCONTRACTOR	Divisions of Work (Painting, electrical, landscaping, etc.)	Date Solicitation Letter / Fax Sent	PHONE CONTACT		BID ACTIVITY Check Yes or No			REJECTED BIDS (if bid received & not used)		Notes
			Date of Call	Person Receiving Call	Will Bid	Bid Received	Bid Used	Bid Amount	Reason Not Used (Price, Scope or Other. If Other, explain in Notes>>)	
Brothers Concrete Cutting	Saw Cutting	3/25	N/A		<input type="checkbox"/> Yes <input type="checkbox"/> No	<input type="checkbox"/> Yes <input type="checkbox"/> No	<input type="checkbox"/> Yes <input type="checkbox"/> No	\$350.00		Bid received before calling
Cutting Edge Concrete Cutting	Saw Cutting	3/25	N/A		<input type="checkbox"/> Yes <input type="checkbox"/> No	<input type="checkbox"/> Yes <input type="checkbox"/> No	<input type="checkbox"/> Yes <input type="checkbox"/> No	\$865.00	Price	Bid received before calling
Bedrock Commercial Concrete Cutting LLC	Saw Cutting	3/25	N/A		<input type="checkbox"/> Yes <input type="checkbox"/> No	<input type="checkbox"/> Yes <input type="checkbox"/> No	<input type="checkbox"/> Yes <input type="checkbox"/> No	\$600.00	Price	Bid received before calling
					<input type="checkbox"/> Yes <input type="checkbox"/> No	<input type="checkbox"/> Yes <input type="checkbox"/> No	<input type="checkbox"/> Yes <input type="checkbox"/> No			
					<input type="checkbox"/> Yes <input type="checkbox"/> No	<input type="checkbox"/> Yes <input type="checkbox"/> No	<input type="checkbox"/> Yes <input type="checkbox"/> No			
					<input type="checkbox"/> Yes <input type="checkbox"/> No	<input type="checkbox"/> Yes <input type="checkbox"/> No	<input type="checkbox"/> Yes <input type="checkbox"/> No			
					<input type="checkbox"/> Yes <input type="checkbox"/> No	<input type="checkbox"/> Yes <input type="checkbox"/> No	<input type="checkbox"/> Yes <input type="checkbox"/> No			



CLACKAMAS COUNTY  
PUBLIC IMPROVEMENT CONTRACT

PERFORMANCE BOND

Bond No.: 30145940  
Solicitation: #2022-26  
Project Name: Salmonberry Drive Paving Project

Western Surety Company(Surety #1)	Bond Amount No. 1:	\$ 201,630.00
_____ (Surety #2)*	Bond Amount No. 2:*	\$ _____
<i>* If using multiple sureties</i>	Total Penal Sum of Bond:	\$ 201,630.00

We, S-2 Contractors, Inc. as Principal, and the above identified Surety(ies), authorized to transact surety business in Oregon, as Surety, hereby jointly and severally bind ourselves, our respective heirs, executors, administrators, successors and assigns firmly by these presents to pay unto Clackamas County, the sum of (Total Penal Sum of Bond)~~Two Hundred One Thousand Six Hundred Thirty & No/100---~~(\$201,630.00) Dollars(Provided, that we the Sureties bind ourselves in such sum "jointly and severally" as well as "severally" only for the purpose of allowing a joint action or actions against any or all of us, and for all other purposes each Surety binds itself, jointly and severally with the Principal, for the payment of such sum only as is set forth opposite the name of such Surety); and

WHEREAS, the Principal has entered into a contract with Clackamas County, along with the plans, specifications, terms and conditions of which are contained in the above-referenced Solicitation; and

WHEREAS, the terms and conditions of the contract, together with applicable plans, standard specifications, special provisions, schedule of performance, and schedule of contract prices, are made a part of this Performance Bond by reference, whether or not attached to the contract (all hereafter called "Contract"); and

WHEREAS, the Principal has agreed to perform the Contract in accordance with the terms, conditions, requirements, plans and specifications, and all authorized modifications of the Contract which increase the amount of the work, the amount of the Contract, or constitute an authorized extension of the time for performance, notice of any such modifications hereby being waived by the Surety:

NOW, THEREFORE, THE CONDITION OF THIS BOND IS SUCH that if the Principal herein shall faithfully and truly observe and comply with the terms, conditions and provisions of the Contract, in all respects, and shall well and truly and fully do and perform all matters and things undertaken by Contractor to be performed under the Contract, upon the terms set forth therein, and within the time prescribed therein, or as extended as provided in the Contract, with or without notice to the Sureties, and shall defend, indemnify, and save harmless Clackamas County and its elected officials, officers, employees and agents, against any direct or indirect damages or claim of every kind and description that shall be suffered or claimed to be suffered in connection with or arising out of the performance of the Contract by the Principal or its subcontractors, and shall in

all respects perform said contract according to law, then this obligation is to be void; otherwise, it shall remain in full force and effect for so long as any term of the Contract remains in effect.

Nonpayment of the bond premium will not invalidate this bond nor shall Clackamas County, be obligated for the payment of any premiums.

This bond is given and received under authority of Oregon Revised Statutes Chapter 279C and the Clackamas County Local Contractor Review Board Rules, the provisions of which hereby are incorporated into this bond and made a part hereof.

IN WITNESS WHEREOF, WE HAVE CAUSED THIS INSTRUMENT TO BE EXECUTED AND SEALED BY OUR DULY AUTHORIZED LEGAL REPRESENTATIVES.

Dated this \_\_\_\_\_ day of April, 20 22.



PRINCIPAL: S-2 Contractors, Inc.

By: \_\_\_\_\_

*[Handwritten Signature]*  
Signature

*PRES.*

Official Capacity

Attest: \_\_\_\_\_

*[Handwritten Signature]*  
Corporatfon Secretary

SURETY: Western Surety Company

*[Add signatures for each if using multiple bonds]*

BY ATTORNEY-IN-FACT:

*[Power-of-Attorney must accompany each bond]*

Gloria Bruning

*[Handwritten Signature]*  
Name  
Signature

PO Box 2808

Address

Portland, OR 97208

City State Zip  
503-224-2500 503-224-9830

Phone Fax

# Western Surety Company

## POWER OF ATTORNEY APPOINTING INDIVIDUAL ATTORNEY-IN-FACT

Know All Men By These Presents, That WESTERN SURETY COMPANY, a South Dakota corporation, is a duly organized and existing corporation having its principal office in the City of Sioux Falls, and State of South Dakota, and that it does by virtue of the signature and seal herein affixed hereby make, constitute and appoint

**Philip O Forker, Vicki Mather, Gloria Bruning, J Patrick Dooney, Richard W Kowalski, Brent Olson, Leticia Romano, Joel Dietzman, Christopher A Reburn, Gail A Price, Justin Cumnock, Andrew Choruby, Casey J Geske, Sterling Drew Roddan, Amanda J Lee, Individually**

of Lake Oswego, OR, its true and lawful Attorney(s)-in-Fact with full power and authority hereby conferred to sign, seal and execute for and on its behalf bonds, undertakings and other obligatory instruments of similar nature

### - In Unlimited Amounts -

and to bind it thereby as fully and to the same extent as if such instruments were signed by a duly authorized officer of the corporation and all the acts of said Attorney, pursuant to the authority hereby given, are hereby ratified and confirmed.

This Power of Attorney is made and executed pursuant to and by authority of the By-Law printed on the reverse hereof, duly adopted, as indicated, by the shareholders of the corporation.

In Witness Whereof, WESTERN SURETY COMPANY has caused these presents to be signed by its Vice President and its corporate seal to be hereto affixed on this 14th day of December, 2021.



WESTERN SURETY COMPANY

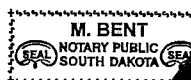
Paul T. Bruflat, Vice President

State of South Dakota }  
County of Minnehaha } ss

On this 14th day of December, 2021, before me personally came Paul T. Bruflat, to me known, who, being by me duly sworn, did depose and say: that he resides in the City of Sioux Falls, State of South Dakota; that he is the Vice President of WESTERN SURETY COMPANY described in and which executed the above instrument; that he knows the seal of said corporation; that the seal affixed to the said instrument is such corporate seal; that it was so affixed pursuant to authority given by the Board of Directors of said corporation and that he signed his name thereto pursuant to like authority, and acknowledges same to be the act and deed of said corporation.

My commission expires

March 2, 2026



M. Bent, Notary Public

### CERTIFICATE

I, L. Nelson, Assistant Secretary of WESTERN SURETY COMPANY do hereby certify that the Power of Attorney hereinabove set forth is still in force, and further certify that the By-Law of the corporation printed on the reverse hereof is still in force. In testimony whereof I have hereunto subscribed my name and affixed the seal of the said corporation this April day of 2022



WESTERN SURETY COMPANY

L. Nelson, Assistant Secretary



CLACKAMAS COUNTY
PUBLIC IMPROVEMENT CONTRACT

PAYMENT BOND

Bond No.: 30145940
Solicitation: #2022-26
Project Name: Salmonberry Drive Paving Project

Table with 3 columns: Surety Name, Bond Amount No., and Amount. Includes entries for Western Surety Company (Surety #1), (Surety #2)\*, and Total Penal Sum of Bond.

We, S-2 Contractors, Inc., as Principal, and the above identified Surety(ies), authorized to transact surety business in Oregon, as Surety, hereby jointly and severally bind ourselves, our respective heirs, executors, administrators, successors and assigns firmly by these presents to pay unto Clackamas County, the sum of (Total Penal Sum of Bond) Two Hundred One Thousand Six Hundred Thirty & No/100--(\$201,630.00) Dollars

WHEREAS, the Principal has entered into a contract with Clackamas County, along with the plans, specifications, terms and conditions of which are contained in above-referenced Solicitation; and

WHEREAS, the terms and conditions of the contract, together with applicable plans, standard specifications, special provisions, schedule of performance, and schedule of contract prices, are made a part of this Payment Bond by reference, whether or not attached to the contract (all hereafter called "Contract"); and

WHEREAS, the Principal has agreed to perform the Contract in accordance with the terms, conditions, requirements, plans and specifications, and schedule of contract prices which are set forth in the Contract and any attachments, and all authorized modifications of the Contract which increase the amount of the work, or the cost of the Contract, or constitute authorized extensions of time for performance of the Contract, notice of any such modifications hereby being waived by the Surety:

NOW, THEREFORE, THE CONDITION OF THIS BOND IS SUCH that if the Principal shall faithfully and truly observe and comply with the terms, conditions and provisions of the Contract, in all respects, and shall well and truly and fully do and perform all matters and things by it undertaken to be performed under said Contract and any duly authorized modifications that are made, upon the terms set forth therein, and within the time prescribed therein, or as extended therein as provided in the Contract, with or without notice to the Sureties, and shall defend, indemnify, and save harmless Clackamas County and its elected officials, officers, employees and agents, against any claim for direct or indirect damages of every kind and description that shall be suffered or claimed to be suffered in connection with or arising out of the performance of the Contract by the Contractor or its subcontractors, and shall promptly pay all persons supplying labor, materials or both to the Principal or its subcontractors for prosecution of the work provided in the Contract; and shall promptly pay all contributions due the State Industrial Accident Fund and the State Unemployment Compensation Fund from the Principal or its subcontractors in connection with the performance of the Contract; and shall pay over to the Oregon Department of Revenue all sums required to be deducted and retained from the wages of employees of the Principal and its subcontractors pursuant to ORS 316.167, and

shall permit no lien nor claim to be filed or prosecuted against Clackamas County on account of any labor or materials furnished; and shall do all things required of the Principal by the laws of this State, then this obligation shall be void; otherwise, it shall remain in full force and effect for so long as any term of the Contract remains in effect.

Nonpayment of the bond premium will not invalidate this bond nor shall Clackamas County be obligated for the payment of any premiums.

This bond is given and received under authority of Oregon Revised Statutes Chapter 279C and the Clackamas County Local Contractor Review Board Rules, the provisions of which hereby are incorporated into this bond and made a part hereof.

IN WITNESS WHEREOF, WE HAVE CAUSED THIS INSTRUMENT TO BE EXECUTED AND SEALED BY OUR DULY AUTHORIZED LEGAL REPRESENTATIVES:

Dated this \_\_\_\_\_ day of April, 20 22 .



PRINCIPAL: S-2 Contractors, Inc

By: \_\_\_\_\_  
Signature

*Pres.*

Official Capacity

Attest: \_\_\_\_\_  
Corporation Secretary

SURETY: Western Surety Company

[Add signatures for each if using multiple bonds]

BY ATTORNEY-IN-FACT:

[Power-of-Attorney must accompany each bond]

Gloria Bruning  
Name

Gloria Bruning  
Signature

PO Box 2808  
Address

Portland, OR 97208  
City State Zip

503-224-2500 503-224-9830  
Phone Fax

# Western Surety Company

## POWER OF ATTORNEY APPOINTING INDIVIDUAL ATTORNEY-IN-FACT

Know All Men By These Presents, That WESTERN SURETY COMPANY, a South Dakota corporation, is a duly organized and existing corporation having its principal office in the City of Sioux Falls, and State of South Dakota, and that it does by virtue of the signature and seal herein affixed hereby make, constitute and appoint

**Philip O Forker, Vicki Mather, Gloria Bruning, J Patrick Dooney, Richard W Kowalski, Brent Olson, Leticia Romano, Joel Dietzman, Christopher A Reburn, Gail A Price, Justin Cumnock, Andrew Choruby, Casey J Geske, Sterling Drew Roddan, Amanda J Lee, Individually**

of Lake Oswego, OR, its true and lawful Attorney(s)-in-Fact with full power and authority hereby conferred to sign, seal and execute for and on its behalf bonds, undertakings and other obligatory instruments of similar nature

### - In Unlimited Amounts -

and to bind it thereby as fully and to the same extent as if such instruments were signed by a duly authorized officer of the corporation and all the acts of said Attorney, pursuant to the authority hereby given, are hereby ratified and confirmed.

This Power of Attorney is made and executed pursuant to and by authority of the By-Law printed on the reverse hereof, duly adopted, as indicated, by the shareholders of the corporation.

In Witness Whereof, WESTERN SURETY COMPANY has caused these presents to be signed by its Vice President and its corporate seal to be hereto affixed on this 14th day of December, 2021.



WESTERN SURETY COMPANY

*Paul T. Bruflat*

Paul T. Bruflat, Vice President

State of South Dakota }  
County of Minnehaha } ss

On this 14th day of December, 2021, before me personally came Paul T. Bruflat, to me known, who, being by me duly sworn, did depose and say: that he resides in the City of Sioux Falls, State of South Dakota; that he is the Vice President of WESTERN SURETY COMPANY described in and which executed the above instrument; that he knows the seal of said corporation; that the seal affixed to the said instrument is such corporate seal; that it was so affixed pursuant to authority given by the Board of Directors of said corporation and that he signed his name thereto pursuant to like authority, and acknowledges same to be the act and deed of said corporation.

My commission expires  
March 2, 2026



*M. Bent*

M. Bent, Notary Public

### CERTIFICATE

I, L. Nelson, Assistant Secretary of WESTERN SURETY COMPANY do hereby certify that the Power of Attorney hereinabove set forth is still in force, and further certify that the By-Law of the corporation printed on the reverse hereof is still in force. In testimony whereof I have hereunto subscribed my name and affixed the seal of the said corporation this day of April 2022



WESTERN SURETY COMPANY

*L. Nelson*

L. Nelson, Assistant Secretary





CLACKAMAS COUNTY
PUBLIC IMPROVEMENT CONTRACT

PAYMENT BOND

Bond No.:
Solicitation: #2022-26
Project Name: Salmonberry Drive Paving Project

(Surety #1) Bond Amount No. 1: \$
(Surety #2)\* Bond Amount No. 2:\* \$
\* If using multiple sureties Total Penal Sum of Bond: \$

We, as Principal, and the above identified Surety(ies), authorized to transact surety business in Oregon, as Surety, hereby jointly and severally bind ourselves, our respective heirs, executors, administrators, successors and assigns firmly by these presents to pay unto Clackamas County, the sum of (Total Penal Sum of Bond) (Provided, that we the Sureties bind ourselves in such sum "jointly and severally" as well as "severally" only for the purpose of allowing a joint action or actions against any or all of us, and for all other purposes each Surety binds itself, jointly and severally with the Principal, for the payment of such sum only as is set forth opposite the name of such Surety); and

WHEREAS, the Principal has entered into a contract with Clackamas County, along with the plans, specifications, terms and conditions of which are contained in above-referenced Solicitation; and

WHEREAS, the terms and conditions of the contract, together with applicable plans, standard specifications, special provisions, schedule of performance, and schedule of contract prices, are made a part of this Payment Bond by reference, whether or not attached to the contract (all hereafter called "Contract"); and

WHEREAS, the Principal has agreed to perform the Contract in accordance with the terms, conditions, requirements, plans and specifications, and schedule of contract prices which are set forth in the Contract and any attachments, and all authorized modifications of the Contract which increase the amount of the work, or the cost of the Contract, or constitute authorized extensions of time for performance of the Contract, notice of any such modifications hereby being waived by the Surety:

NOW, THEREFORE, THE CONDITION OF THIS BOND IS SUCH that if the Principal shall faithfully and truly observe and comply with the terms, conditions and provisions of the Contract, in all respects, and shall well and truly and fully do and perform all matters and things by it undertaken to be performed under said Contract and any duly authorized modifications that are made, upon the terms set forth therein, and within the time prescribed therein, or as extended therein as provided in the Contract, with or without notice to the Sureties, and shall defend, indemnify, and save harmless Clackamas County and its elected officials, officers, employees and agents, against any claim for direct or indirect damages of every kind and description that shall be suffered or claimed to be suffered in connection with or arising out of the performance of the Contract by the Contractor or its subcontractors, and shall promptly pay all persons supplying labor, materials or both to the Principal or its subcontractors for prosecution of the work provided in the Contract; and shall promptly pay all contributions due the State Industrial Accident Fund and the State Unemployment Compensation Fund from the Principal or its subcontractors in connection with the performance of the Contract; and shall pay over to the Oregon Department of Revenue all sums required to be deducted and retained from the wages of employees of the Principal and its subcontractors pursuant to ORS 316.167, and

shall permit no lien nor claim to be filed or prosecuted against Clackamas County on account of any labor or materials furnished; and shall do all things required of the Principal by the laws of this State, then this obligation shall be void; otherwise, it shall remain in full force and effect for so long as any term of the Contract remains in effect.

Nonpayment of the bond premium will not invalidate this bond nor shall Clackamas County be obligated for the payment of any premiums.

This bond is given and received under authority of Oregon Revised Statutes Chapter 279C and the Clackamas County Local Contractor Review Board Rules, the provisions of which hereby are incorporated into this bond and made a part hereof.

IN WITNESS WHEREOF, WE HAVE CAUSED THIS INSTRUMENT TO BE EXECUTED AND SEALED BY OUR DULY AUTHORIZED LEGAL REPRESENTATIVES:

Dated this \_\_\_\_\_ day of \_\_\_\_\_, 20\_\_.

**PRINCIPAL:** \_\_\_\_\_

By: \_\_\_\_\_  
Signature

\_\_\_\_\_  
Official Capacity

Attest: \_\_\_\_\_  
Corporation Secretary

**SURETY:** \_\_\_\_\_  
*[Add signatures for each if using multiple bonds]*

**BY ATTORNEY-IN-FACT:**  
*[Power-of-Attorney must accompany each bond]*

\_\_\_\_\_  
Name

\_\_\_\_\_  
Signature

\_\_\_\_\_  
Address

\_\_\_\_\_  
City State Zip

\_\_\_\_\_  
Phone Fax



CLACKAMAS COUNTY  
PUBLIC IMPROVEMENT CONTRACT  
PROJECT INFORMATION, PLANS, SPECIFICATIONS AND DRAWINGS

**PROJECT: #2022-26 Salmonberry Drive Paving Project**

**Project Background:**

The Salmonberry Drive Paving Package is an asphalt paving project. This contract will resurface about 0.3 miles of roads. This contract will resurface two local roads and they are: Salmonberry Drive and Columbine Court.

Road improvements will also include placing approximately, 1200 tons of asphalt; reconditioning 5,055 square yards of asphalt surfaces; installing, maintaining, and removing temporary work zone traffic control measures; and performing additional incidental work as called for by the specifications and plans.

**Engineers Estimate:** \$200,000.00

**Key Dates:**

All Basic Bid Work may begin as soon as the Notice to Proceed (“NTP”) is issued

Substantial Completion: September 1, 2022

Final Completion: December 31, 2022

Time is of the essence for this Project. Note the Liquidated Damages requirements as described in the project Specifications.

**The Scope further includes the following Plans, Specifications and Drawings:**

SPECIAL PROVISIONS FOR Salmonberry Paving Project, dated Summer 2022

SALMONBERRY DRIVE LOCAL PAVING PROJECT Drawing Set, Sheets No. 1-6

**SPECIAL PROVISIONS**

**FOR**

**Salmonberry Paving Project**

**CLACKAMAS COUNTY DEPARTMENT OF  
TRANSPORTATION AND DEVELOPMENT**

**CLACKAMAS COUNTY, OREGON**

Asphalt Paving & Oiling and Temporary Traffic Control

**Summer 2022**






CLACKAMAS COUNTY DEPARTMENT OF TRANSPORTATION AND DEVELOPMENT

SPECIAL PROVISIONS

FOR

**SALMONBERRY DRIVE PAVING PROJECT**

**PROFESSIONAL OF RECORD CERTIFICATION(s):**

<p>Seal w/signature</p>  <p>RENEWAL DATE: 6/30/2023</p>	<p>I certify the Special Provision Sections listed below are applicable to the design for the Salmonberry Drive Paving Project.</p> <p>Sections: 00210, 00220, 00221, 00222, 00225, 00280, 00290, 00310, 00440, 00470, 00480, 00490, 00620, 00744, 00748, and 00867.</p>
<p>Date Signed: <u>1/21/2022</u></p>	



## **SPECIAL PROVISIONS**

### **WORK TO BE DONE**

#### **SALMONBERRY DRIVE PAVING PROJECT, CLACKAMAS COUNTY, OREGON**

The Salmonberry Drive Paving Project is an asphalt paving project. This contract will resurface about 0.3 miles of road.

This contract will resurface two local roads and they are: Salmonberry Drive and Columbine Court.

This contract will include, but not be limited to: placing approximately 1200 tons of asphalt; reconditioning 5,055 square yards of asphalt surfaces; installing, maintaining, and removing temporary work zone traffic control measures; and performing additional incidental work as called for by the specifications and plans. The project estimate for this contract is \$200,000.

### **AUTHORITY OF CONSULTANT**

The consultant will be directly in charge of the Project. However, the consultant's authority on this Project is as designated in the official "Consultant Agreement" for this Project, and as designated by the Engineer. This does not include authority to approve Contract changes or semifinal and Final Inspection of the Project.

### **APPLICABLE SPECIFICATIONS**

The Specification that is applicable to the Work on this Project is the 2021 edition of the "Oregon Standard Specifications for Construction" produced by the Oregon Department of Transportation and the Oregon Chapter or the APWA.

All number references in these Special Provisions shall be understood to refer to the Sections and subsections of the Standard Specifications and Supplemental Specifications bearing like numbers and to Sections and subsections contained in these Special Provisions in their entirety.

### **CLASS OF PROJECT**

This is a Clackamas County Project and it is not federally funded.

### **CLASS OF WORK**

Asphalt Concrete Paving and Oiling (ACP)  
Temporary Traffic Control (TTC)



## **Section 00110 – Organization, Conventions, Abbreviations and Definitions**

Comply with Section 00110 of the Standard Specifications modified as follows:

**00110.05(a) Grammar** - Add the following bullet to the bullet list:

For the purposes of this Contract, the terms "sidewalk ramp" and "sidewalk ramps" shall respectively refer to and shall be read to mean "curb ramp" and "curb ramps".

Replace the bullet that begins "Certain Subsections labeled "Payment" contain..." with the following bullet:

Certain Subsections labeled "Payment" contain statements to the effect that the accepted quantities "will be paid for at the Contract unit price, per unit of measurement, for the following items" (followed by a list of items). In such cases, the Agency will pay for only those Pay Items listed in the Schedule of Items.

**00110.05(d) References to Laws, Acts, Regulations, Rules, Ordinances, Statutes, Orders, and Permits**

Add the following to the first bullet (Statutes and Rules):

- Clackamas County's Local Contract Review Board (LCRB) Rules are accessible online on the County's website <https://dochub.clackamas.us/documents/drupal/ef976bc9-14f4-495b-9bd8-c69ee7334685>.

**00110.05(e) Reference to Websites** - Add the following bullet list to the end of this subsection:

American Traffic Safety Services Association (ATSSA)  
[www.atssa.com](http://www.atssa.com)

ODOT Construction Section  
[www.oregon.gov/odot/construction/pages/index.aspx](http://www.oregon.gov/odot/construction/pages/index.aspx)

ODOT Construction Section - Qualified Products List (QPL)  
[www.oregon.gov/ODOT/Construction/Pages/Qualified-Products.aspx](http://www.oregon.gov/ODOT/Construction/Pages/Qualified-Products.aspx)

Oregon Legislative Counsel  
[www.oregonlegislature.gov/lc](http://www.oregonlegislature.gov/lc)

Oregon Secretary of State: State Archives  
[sos.oregon.gov/archives/Pages/default.aspx](http://sos.oregon.gov/archives/Pages/default.aspx)

ODOT Traffic Control Plans Unit  
[www.oregon.gov/ODOT/Engineering/Pages/Work-Zone.aspx](http://www.oregon.gov/ODOT/Engineering/Pages/Work-Zone.aspx)

## 00110.10      **Abbreviations**

Add the following:

CCDA -	Clackamas County Development Agency
DTD -	Clackamas County Department of Transportation and Development
LCRB -	Local Contract Review Board
ODFW -	Oregon Department of Fish and Wildlife
UNS -	Utility Notification System
WES -	Water Environment Services of Clackamas County

## 00110.20      **Definitions**-Add the following to this subsection:

**Agreement Form** – The written agreement between the Owner and Contractor covering the work to be performed under the contract.

**Amendment** – A contract modification for Additional Work, Changed Work, Extra Work, Field Directives, or other changes. An Amendment changes the contract value, scope, and/or time. Amendments require formal approval by the Board of County Commissioners, pursuant to LCRB Rule Division C-049-160, prior to approval of such work.

**Approved Equal** - Materials or services proposed by the contractor and approved by the County as equal substitutes for those materials or services specified.

**Award** – Same as “Notice to Intent to Award”.

**BCC** – The Clackamas County Board of County Commissioners

**Bid** - A written offer by a bidder on forms furnished by the County to do work stated in the bid documents at the prices quoted. "Bid" is synonymous with "proposal" in these bid documents.

**Bid Closing** - The date and time for Bid Closing is the same as the date and time for Bid Opening.

**Bid Documents**- The following documents together comprise the Bid Documents:

- Invitation to Bid, Instructions to Bidders, Bid Form, Bid Proposal, Schedule of Prices, Bid
- Bond, Performance Bond
- Certificate of Insurance, Prevailing Wage Rates
- The "Oregon Standard Specifications for Construction" by ODOT and APWA, 2018 edition.
- Plans and drawings
- Other bid documents included or referenced in the bid documents

- Addenda, if any
- The Agreement Form and Special Provisions

**Bonds** -The bond or surety bond is a written document given by the surety and principal to the obligee to guarantee a specific obligation.

**Change Order** - A price agreement for Extra Work, Changed Work, field directives or other changes. A Change Order does not change the contract value, scope, or time until it is incorporated into an Amendment. Change Orders will be agreed upon, in writing, by the County Project Manager and the Contractor's designated representative.

**Contract** - The written contract agreement, including amendments, signed by the Contractor and Clackamas County, which describes the work to be done, the contract amount, and defines the relationships and obligations of the Contractor and the County.

**Contract Documents** - The Invitation to Bid, the Instructions to Bidders, the accepted Bid Proposal and Schedule of Prices, the Subcontractor List, the Bid Bond, the Performance and Payment Bond, the Certificate of Insurance, the Prevailing Wage Rates, the Standard Specifications and Special Provisions, Amendments, the Plans and Drawings, the Agreement, as well as all documents incorporated by reference therein, and any and all addenda prepared by or at the direction of and adopted by the County and further identified by the signature of the parties and all modifications thereof incorporated in the documents before their execution.

**County** - The term "County" shall mean Clackamas County, including the Board of County Commissioners, employees and agents of the County authorized to administer the conditions of these contract documents.

**Department** – A subdivision of the Agency.

**Engineer** - The County's Project Manager either acting directly or through an authorized representative(s). When referring to approval of extra work or other Contract modifications, "Engineer" also refers to the County's legal authority according to the LCRB rules.

**Invitation to Bid** - The public announcement (Notice to Contractors) inviting bids for work to be performed or materials to be furnished.

**Legal Holiday** - As defined in ORS 279C.540.

**Lump Sum** - A method of payment providing for one all-inclusive cost for the work or for a particular portion of the work.

**Notice of Intent to Award** - A written notice from the County notifying bidders that the County intends to award to the responsible bidder submitting lowest responsive bid.

**ODOT Procurement Office** – Clackamas County Procurement Division.

**Owner** – Synonymous with Agency.

**Plan Holder's List** – A list of contractor's names, contact names, phone and fax numbers that the County's Purchasing Department creates during bidding of the Project.

**Project Manager** – The Owner’s representative who directly supervises the engineering and administration of the contract.

**Shop Drawings** – Synonymous with Working Drawings.

**Solicitation Document** – Synonymous with Bid Documents.

**Standard Drawings** – The Agency-prepared detailed drawings for Work or methods of construction that normally do not change from project to project. The Standard Drawings include the ODOT Standard Drawings.

**Standard Specifications** - "Oregon Standard Specifications for Construction", current edition, published by the Oregon Department of Transportation and as amended by **the Agency**.

**State** - Where the term “State” or “State of Oregon” or “ODOT” appears in the contract documents it shall mean “Clackamas County”, “State of Oregon”, or “ODOT” as applicable because of context.

Replace the sentence that begins “**Surfacing** – The Course or Courses...” with the following sentence:

**Surfacing** – The Course or Courses of material on the Traveled Way, auxiliary lanes, Shoulder, or parking areas for pedestrian, bicycle or vehicle use.

**Work Day** - Any and every calendar day from January 1 to December 31 of every year, excluding Saturdays, Sundays and Legal Holidays.

Add the following to the end of this subsection:

See Clackamas County General Conditions for Public Improvement Contracts for additional definitions.

**END OF SECTION**

## Section 00120 – Bidding Requirements and Procedures

Comply with Section 00120 of the Standard Specifications modified as follows:

**00120.00 Prequalification of Bidders** - Replace with the following:

**00120.00 Prequalification of Bidders** - See Clackamas County Public Improvement Contract: Instructions to Bidders.

**00120.01 General Bidding Requirements** – Replace with the following:

**00120.01 General Bidding Requirements** – See Clackamas County Public Improvement Contract: Instructions to Bidders.

**00120.05 Request for Plans, Special Provisions, and Bid Booklets:** – Replace with the following:

**00120.05 Request for Plans, Special Provisions, and Bid Booklets:** – Bid documents may be obtained from the Clackamas County Procurement Division as indicated in Notice of Public Improvement Contract Opportunity.

Copies of the 2018 Oregon Standard Specifications for Construction and Supplements might be found on the Oregon Department of Transportation website at:

[http://www.oregon.gov/ODOT/Business/Pages/Standard\\_Specifications.aspx](http://www.oregon.gov/ODOT/Business/Pages/Standard_Specifications.aspx)

**00120.10 Bid Booklet** - In the paragraph that begins "The Bid Section includes all pages after...", add the following bullet to the bullet list:

Certificate of nondiscrimination regarding ORS 279A.110 and certificate regarding policy and practice against sexual harassment, sexual assault and discrimination against employees who are members of a protected class as required by ORS 279A.112 (House Bill 3060, 2017)

**00120.15 Examination of Work Site and Solicitation Documents; Consideration of Conditions to be Encountered** – Delete the third paragraph.

**00120.30 Changes to Plans, Specifications, or Quantities before Opening of Bids** - Replace with the following:

**00120.30 Changes to Plans, Specifications, or Quantities before Opening of Bids** - See Clackamas County Public Improvement Contract: Instructions to Bidders.

**00120.40 Preparation of Bids** – Replace with the following:

**00120.40 Preparation of Bids** – See Clackamas County Public Improvement Contract: Instructions to Bidders.

**00120.45 Submittal of Bids** - Replace with the following:

**00120.45 Submittal of Bids** - See Clackamas County Public Improvement Contract: Instructions to Bidders.

- 00120.50 Submitting Bids for More than One Contract** – Delete this subsection.
- 00120.60 Revision or Withdrawal of Bids** - Replace with the following:
- 00120.60 Revision or Withdrawal of Bids** - See Clackamas County Public Improvement Contract: Instructions to Bidders.
- 00120.68 Mistakes in Bids** – Replace with the following:
- 00120.68 Mistakes in Bids** – See Clackamas County Public Improvement Contract: Instructions to Bidders.
- 00120.70 Rejection of Nonresponsive Bids** – Replace with the following:
- 00120.70 Rejection of Nonresponsive Bids** – See Clackamas County Public Improvement Contract: Instructions to Bidders.
- 00120.95 Opportunity for Cooperative Arrangement** – Delete this subsection.

## **END OF SECTION**

### **Section 00130 – Award and Execution of Contract**

Comply with Section 00130 of the Standard Specifications modified as follows:

- 00130.00 Consideration of Bids** - Delete third paragraph.
- 00130.10 Award of Contract** - Replace with the following:
- 00130.10 Award of Contract** - See Clackamas County Public Improvement Contract: Instructions to Bidders.
- 00130.15 Right to Protest Award** – Replace with the following:
- 00130.15 Right to Protest Award** – See Clackamas County Public Improvement Contract: Instructions to Bidders.
- 00130.30 Contract Booklet** – Add the following:

Other documents are part of the contract documents by reference. These include, but are not limited to:

- The "Oregon Standard Specifications for Construction", 2018 Edition, as published by the Oregon Department of Transportation (ODOT).
- "Oregon Standard Drawings" latest edition, as published by ODOT.

- Clackamas County Service District No. 1 "Surface Water Standard Specifications", latest edition.

**00130.40 Contract Submittals** - Replace with the following:

**00130.40 Contract Submittals** - See Clackamas County Public Improvement Contract: Instructions to Bidders.

**00130.70 Release of Bid Guaranties** – Replace with the following:

**00130.70 Release of Bid Guaranties** – See Clackamas County Public Improvement Contract: Instructions to Bidders.

**00130.80 Project Site Restriction-** Replace the paragraph that begins "Until the Agency sends...", with the following paragraph:

Until the Agency sends the Contractor written Notice to Proceed with the Work, and the Contractor has filed the public works bonds required in 00170.20, the Contractor shall not go onto the Project Site on which the Work is to be done, nor move Materials, Equipment or workers onto the Project Site.

## END OF SECTION

### Section 00140 – Scope of Work

Comply with Section 00140 of the Standard Specifications supplemented modified as follows:

**00140.30 Agency-Required Changes in the Work** – Replace the last paragraph with the following:

Upon receipt of an Engineer's written order modifying the Work, the Contractor shall perform the Work as modified via Change Order, which may be subject to approval as an Amendment.

If an Amendment incorporating changes to the Work increases the Contract amount, the Contractor shall notify its Surety of the increase and shall provide the Agency with a copy of any resulting modification to bond documents. The Contractor's performance of Work pursuant to Amendments shall neither invalidate the Contract nor release the Surety. Payment for changes in the Work shall be made in accordance with 00195.20. Contract Time adjustments shall be made in accordance with 00180.80.

**00140.31 "As-Built" Records** - Add the following:

Maintain a current and accurate record of the work completed during the course of this contract. This may be in the form of "as-built" drawings kept by accurately marking a designated set of the contract plans with the specified information as the Work proceeds. Accurate, complete and current "as-built" drawings are a specified requirement for full partial payment of the work

completed. At project completion and as a condition of final payment, the Contractor shall deliver to the Project Manager a complete and legible set of "as-built" drawings.

The "as-built" drawings must show the information listed below. Where the term "locate" or "location" is used, it shall mean record of position with respect to both the construction vertical datum and either construction horizontal datum or a nearby permanent improvement.

- 1) Record location of underground services and utilities as installed.
- 2) Record location of existing underground utilities and services that are to remain and that are encountered during the course of the work.
- 3) Record changes in dimension, location, grade or detail to that shown on the plans.
- 4) Record changes made by change order.
- 5) Record details not in the original plans.
- 6) Provide fully completed shop drawings reflecting all revisions.

## **END OF SECTION**

### **Section 00150 – Control of Work**

Comply with Section 00150 of the Standard Specifications modified as follows:

**00150.00 Authority of the Engineer** – Replace the first sentence with the following:

Except as indicated elsewhere in the Contract (e.g. Amendment approval by the BCC), the Engineer has full authority over the Work and its suspension.

**00150.05 Cooperative Arrangements** – Delete this subsection.

**00150.10 Coordination of Contract Documents**

**(a) Order of Precedence** – Replace with the following:

The Engineer will resolve any discrepancies between these documents in the following order of precedence:

- Approved Amendments;
- Approved Change Orders;
- Bid Schedule with Schedule of Prices;
- Permits from governmental agencies;
- Special Provisions;



- Agency-prepared drawings specifically applicable to the Project and bearing the Project title;
- Reviewed and accepted, stamped Working Drawings;
- Agreement Form;
- Standard Drawings;
- Approved Unstamped Working Drawings;
- Standard Specifications;
- All other Contract Documents not listed above.

Notes on a drawing shall take precedence over drawing details.

Dimensions shown on the drawings, or that can be computed, shall take precedence over scaled dimensions.

**00150.50 Cooperation with Utilities:** Add the following to the end of Paragraph (a):

There may be other utility servers who are not specifically listed in these Special Provisions or on the Plans that may be adjusting or inspecting their facilities within the project limits.

**00150.50(c) Contractor Responsibilities** – Add the following to the bulleted list:

- Follow applicable rules adopted by the Oregon Utility Notification Center;
- Contact Utility owners during Bid preparation and after Contract is awarded to verify all Utilities involvement on the Project Site;
- Hold a utility scheduling meeting and monthly utility coordination meetings (see also 00180.42);
- Coordinate Project construction with Utilities' planned adjustments, take all precautions necessary to prevent disruption of Utility service, and perform its Work in the manner that results in the least inconvenience to the Utility owners;
- Include all Utility adjustment work, whether to be performed by the Contractor or the Utilities, on the Contractor's Project Work schedule submitted under 00180.41;
- Protect from damage or disturbance any Utility that remains within the area in which Work is being performed. Maintain and re-establish utility location marks according to OAR 952-001-0090(2)(a). Coordinate re-establishment of the location marks with the associated Utility;
- Not disturb an existing Utility if it requires an unanticipated adjustment, but shall protect the Utility from damage or disturbance and promptly notify the Engineer;
- Determine the exact location before excavating within the reasonable accuracy zone according to OAR 952-001-0090(2)(c);
- Backfill any exposed utilities as recommended and approved by the Utility representative. Obtain utility locate warning tape from the Utility and replace damaged or removed warning tape. Utility locate warning tape may not be present at all existing utilities;
- Stake, place warning tape, and maintain no work limits around critical Utility facilities as shown or directed by the Engineer and the Utility;
- In addition to the notification required in OAR 952-001-0090(5), notify the Engineer and the Utility as soon as the Contractor discovers any previously unknown Utility conflicts or issues. Contrary to the OAR, stop excavating until directed by the Engineer and

- allow the Utility a minimum of two weeks to relocate or resolve the previously unknown utility issues;
- Report to the Engineer any Utility owner who fails to cooperate or fails to follow the planned Utility adjustment.

Subject to the Engineer's approval, the Contractor may adjust the Utilities by asking the Utility owners to move, remove, or alter their facilities in ways other than as shown on the Plans or in the Special Provisions. The Contractor shall conduct all negotiations, make all arrangements, and assume all costs that arise from such changes.

The existing underground utilities shown on the Plans have been determined by as-built records and field surveys, but are not guaranteed to be complete or accurate. The Contractor shall be responsible for contacting the individual utility companies to mark locations, and arranging with them for any relocation work that should be required.

The Contractor shall make excavations and borings ahead of the work where necessary to determine the exact location of underground pipes or other features, which might interfere with construction. The Contractor shall support and protect pipes or other services where they cross the trench and shall be responsible for all damages incidental in interruptions of service that may be caused by Contractor operations. Where a new utility line crosses an existing pipeline or other conduit, the trench backfill shall be well compacted in a manner that provides for the required backfill and compaction standards while protecting the utility in question.

**00150.70 Detrimental Operations** – Add the following:

Portions of this project will be constructed in close proximity to existing private improvements. All private improvements disturbed by the Contractor's operations shall be repaired or replaced to equal or better condition at the Contractor's expense. The Engineer may withhold from future payments to the Contractor, an amount equal to the costs reasonably estimated by the Engineer to repair or replace, as the case may be, those private improvements disturbed by the Contractor's operations. Engineer shall release the retained amount once Engineer has determined that the Contractor has completed the repair consistent with the requirements of this provision. In addition, prior to construction, the Contractor shall provide to the Engineer video showing private property, which may be disturbed during construction.

**END OF SECTION**

**Section 00160 – Source of Materials**

Comply with Section 00160 of the Standard Specifications modified as follows:

**00160.05 Qualified Products List (QPL)** - Replace this subsection, except for the subsection number and title, with the following:

The QPL is a listing of manufactured products available on the market (shelf items) that ODOT has evaluated and found suitable for a specified use in highway construction. The QPL is available from ODOT's Construction Section website at:

<http://www.oregon.gov/ODOT/HWY/CONSTRUCTION/pages/index.aspx>

The most current published PDF version of the QPL on ODOT's Construction Section website at the time of Advertisement is the version in effect for the Project. The Engineer may approve for use a conditionally qualified product, or a product qualified for inclusion in a later edition of the QPL, if the Engineer finds the product acceptable for use on the Project.

Use of listed products shall be restricted to the category of use for which they are listed. The Contractor shall install all products as recommended by the manufacturer. The Contractor shall replace qualified products not conforming to Specifications or not properly handled or installed at no additional cost to the Agency.

**00160.20(a) Buy America** – Replace with the following: Federal highway funds are NOT involved on this Project.

## END OF SECTION

### Section 00165 – Quality of Materials

Comply with Section 00165 of the Standard Specifications modified as follows:

**00165.04 Costs of Testing** – Replace this section with the following sentence: All testing required to be performed by the Contractor will be at the Contractor's expense.

**00165.10(a) Field-Tested Materials** – Add the following sentence: The County follows the most current version of the MFTP on its projects:

**00165.10(b) Nonfield-Tested Materials** - Add the following sentence:

The County follows the most current version of the NTMAG on its projects.

**00165.91 Fabrication Inspection Expense** - In the paragraph that begins "Fabrication of certain items...", replace the sentence that begins "Therefore, each time that..." with the following sentence:

Therefore, each time that inspection by or on behalf of the Agency is necessary, payment to the Contractor will be reduced by an amount computed at the following rates:

In the paragraph that begins "This Subsection applies to all...", replace the first sentence, but not the bullet list, with the following sentence:

This Subsection applies to all fabricated items or manufactured Materials that are inspected by or on behalf of the Agency, which include, but are not limited to:

## END OF SECTION

## Section 00170 – Legal Relations and Responsibilities

Comply with Section 00170 of the Standard Specifications modified as follows:

**00170.04 Patents, Copyrights, and Trademarks** - Replace the paragraph that begins " Prior to use of designs, devices, materials, or processes..." with the following paragraph:

Prior to use of designs, devices, materials, or processes protected by patent, copyright, or trademark, the Contractor shall obtain from the Entity entitled to enforce the patent, copyright, or trademark all necessary evidence of Contractor's legal right to use such design, device, material, or process.

**00170.05 Assignment of Antitrust Rights** - Replace the bullet that reads "ORS 646.725; and" with the following bullet:

ORS 646.725; or

**00170.07 Record Requirements** - In the paragraph that begins "For purposes of this Subsection, the term...", replace the words "OAR 731-005-0780" with the words "OAR 734-010-0400".

**00170.07(a) Records Required** - In the paragraph that begins "These records shall include...", replace the bullet that begins "Contracts or documents of other...", with the following bullet:

Contracts or documents of other arrangements with any Related Entity as defined in OAR 734-010-0400.

In the paragraph that begins "The Contractor shall include...", replace the words "OAR 731-005-0780" with the words "OAR 734-010-0400".

**00170.07(b) Access to Records** - In the paragraph that begins "The Contractor shall provide...", replace the words "OAR 731-005-0780(9)" with the words "OAR 734-010-0400(9)".

**00170.61(a) Workers' Compensation** - In the paragraph, replace "00170.70(d)" with "the Agreement".

**00170.62 Labor Nondiscrimination** - Add the following sentence to the end of this subsection:

It is a material term of this Contract that the Contractor certifies by entering into this Contract that the Contractor has a written policy and practice that meets the requirements described in ORS 279A.112 (House Bill 3060, 2017) for preventing sexual harassment, sexual assault and discrimination against employees who are members of a protected class and that the Contractor shall maintain the policy and practice in force during the entire term of this Contract.

**00170.65(a) General:** Replace the paragraph that begins " As required by ORS 279C.520, compliance by the ..." with the following paragraphs:

As required by ORS 279C.520, the Contractor shall comply with ORS 652.220 and shall not unlawfully discriminate against any of Contractor's employees in the payment of wages or other

compensation for work of comparable character on the basis of an employee's membership in a protected class. "Protected class" means a group of persons distinguished by race, color, religion, sex, sexual orientation, national origin, marital status, veteran status, disability, or age. Contractor's compliance with this provision constitutes a material element of the Contract and failure to comply constitutes a material breach that entitles the Agency to exercise any remedies available under the Contract, including, but not limited to, termination for default.

As required by ORS 279C.520, the Contractor shall not prohibit any of the Contractor's employees from discussing the employee's rate of wage, salary, benefits or other compensation with another employee or another person and shall not retaliate against an employee who discusses the employee's rate of wage, salary, benefits or other compensation with another employee or another person.

Add the following subsection:

**00170.67 Fees** - The fee required by ORS 279C.825(1) will be paid by the Agency to the Commissioner of the Oregon Bureau of Labor and Industries under the administrative rules of the Commissioner.

**00170.70 Insurance** - Replace with the following:

**00170.70 Insurance** - See Clackamas County Public Improvement Contract.

**00170.70(c) Additional Insured** - Add the following paragraph and bullets to the end of this subsection:

Add the following as Additional Insureds under the Contract:

Clackamas County and its officers, agents, and employees  
Clackamas County Board of Commissioners

**00170.72 Indemnity/Hold Harmless** – Replace with the following:

**00170.72 Indemnity/Hold Harmless** – See Clackamas County Public Improvement Contract.

Extend indemnity and hold harmless to the Agency and the following:

- Clackamas County and its officers, agents, and employees
- Clackamas County Board of Commissioners

**00170.79 Third Party Beneficiary** – Replace the text of this section with the following:

- Third-party beneficiaries to the Contract include the Oregon Department of Transportation and its officers, agents, and employees.

**END OF SECTION**

## Section 00180 – Prosecution and Progress

Comply with Section 00180 of the Standard Specifications modified as follows:

**00180.05 Assignment/Delegation of Contract** – Replace this subsection, except for the subsection number and title, with the following:

Unless the Agency gives prior written consent, which will not be unreasonably withheld, the Contractor shall not assign, delegate, sell, or otherwise transfer or dispose of any rights or obligations under the Contract, whether voluntarily or involuntarily, and whether by merger, consolidation, dissolution, operation of law, or any other manner, including, without limitation:

The power to execute or duty to perform the Contract; or

- Any of its right, title or interest in the Contract.

Any purported or attempted assignment, delegation, sale, transfer or disposition without prior Agency consent shall be voidable.

If written Agency consent is given to assign, delegate, sell, or otherwise transfer or dispose of any rights or obligations under the Contract, such consent shall not relieve the Contractor or its Surety of any part of their duties, obligations, responsibilities, or liabilities under or pursuant to the Contract.

**00180.06 Assignment of Funds Due under the Contract** – Replace this subsection, except for the subsection number and title, with the following:

Assignment of funds due or to become due under the Contract to the Contractor will not be permitted unless:

The assignment request is made on the form provided by the Agency;

- The Contractor secures the written consent of the Contractor's Surety to the assignment; and

The Engineer gives prior written consent to the assignment, which will not be unreasonably withheld.

**00180.20(b) Own Organization** - Replace this subsection, except for the subsection number and title, with the following:

The term "own organization", as used in Section 00180, includes only employees of the Contractor, Equipment owned or rented by the Contractor, Incidental rental of operated Equipment, truck hauling of Materials not included in or requiring a subcontract, and Materials and Equipment to be incorporated into the Work purchased or produced by the Contractor.

**00180.20(c)(2) Limitations** - Replace this subsection, except for the subsection number and title, with the following:

The use of Equipment rented with operators is limited to performing minor, Incidental, short-duration work or services under the direct supervision of the Contractor or Subcontractor, with

Equipment not customarily owned, rented, leased, or operated by a Contractor, or with Equipment that is temporarily unavailable to the Contractor.

**00180.20(c)(3) Submittals** - Replace this subsection, except for the subsection number and title, with the following:

The Contractor shall provide the Engineer with a copy of the rental agreement or purchase order covering the work or service to be provided. The Contractor shall make certain that the provider of approved work or services submits payrolls required under Section 00170 and complies with applicable Contract provisions, including, without limitation, 00170.07. The work or service provider will not be considered a Subcontractor under the Contract, but the work or services will be considered to have been performed by the Contractor's own organization for the purposes of determining compliance with 00180.20(a).

**00180.20(e) Trucking** - Replace the paragraph that begins " This Section does not apply to delivery ..." with the following paragraph:

This Section does not apply to delivery of Materials by or for or from a Supplier. This subsection applies to all truck hauling of Materials not performed with trucks owned (or rented) and operated by the Contractor:

**00180.20(e)(2) Limitations** - Replace this subsection, except for the subsection number and title, with the following:

The approved trucking services agreements shall be used for all trucking services for hauling Materials not provided by trucks owned (or rented) and operated by the Contractor except for trucking services provided by committed DBEs that require a subcontract under 00180.21. The Contractor shall execute a trucking services agreement with every trucking services provider for hauling Materials prior to the trucking services provider doing any Work on the Project Site.

**00180.20(e)(3) Submittals** - Replace this subsection, except for the subsection number and title, with the following:

The Contractor shall provide the Engineer with an executed copy of the trucking services agreement not later than 2 Days after the trucking services provider for hauling Materials has started work. The Contractor shall make certain that the provider of approved trucking services submits payrolls required under Section 00170, complies with applicable Contract provisions, including, without limitation, 00170.07, and complies with applicable trucking services agreement provisions. The work or service provider will not be considered a Subcontractor under the Contract, but the work or services will be considered to have been performed by the Contractor's own organization for the purposes of determining compliance with 00180.20(a). If the trucking services are provided by an owner/operator:

Attach a copy of the data required under 00170.65(b)(4) to the trucking services agreement; and

- Each truck shall have the name of the owner/operator clearly displayed on the side of the truck.

**00180.21(a) Subcontracting** - Add the following to the end of this subsection:

All contracts with subcontractors or suppliers shall have provisions making the contract assignable to the County, at the option of the County, if the Contractor terminates, goes out of business, declares bankruptcy, or otherwise is unable to perform provided that the County gives the subcontractor notice of assignment within fourteen (14) days of learning of the inability of the Contractor to perform.

The Engineer may revoke consent to subcontract. If the Engineer revokes consent to subcontract, the subcontractor shall be immediately removed from the Project Site.

**00180.21(d) Terms of Subcontracts** - Replace the paragraph that begins " Subcontracts shall provide that work performed under ..." with the following paragraph:

- All subcontracts shall provide that work performed under the subcontract shall be conducted and performed according to, and shall include, the pertinent requirements, provisions, terms, and conditions of the Contract. Compliance with 00170.07 is required. All subcontracts, including Contractor's with the first-tier Subcontractors and those of the first-tier Subcontractors with their Subcontractors, and any other lower-tier subcontracts shall contain a clause or condition that if the Contractor or a Subcontractor fails, neglects, or refuses to make payment to an Entity furnishing labor or Materials in connection with the Contract, the Entity may file a complaint with the Construction Contractors Board, unless payment is subject to a good-faith dispute as defined in ORS 279C.580. Additionally, according to the provisions of ORS 279C.580, subcontracts shall include:

**00180.22 Payments to Subcontractors and Agents of the Contractor** - Replace the paragraph that begins "To the extent practicable..." with the following paragraph:

To the extent practicable, the Contractor shall pay in the same units and on the same basis of measurement as listed in the Schedule of Items for subcontracted Work or other Work not done by the Contractor's own organization. The Agency will not be responsible for any overpayment or losses resulting from overpayment by the Contractor to subcontractors and to its other agents, work providers, service providers, and trucking services providers.

**00180.40 Limitation of Operations** - Add the following to subsection (a):

The Contractor must provide, at a minimum, a 48-hour notice to the Clackamas County Project Manager in order to perform any work on Saturdays.

**00180.40(b) On-Site Work** – Add the following sentence to the end of this subsection:

The Contractor shall not begin On-Site Work before July 1, 2022, unless approved by the Engineer.

**00180.40(c) Specific Limitations** - Limitations of operations specified in these Special Provisions include, but are not limited to, the following:

<b>Limitations</b>	<b>Subsection</b>
Cooperation with Utilities .....	00150.50



Cooperation with Other Contractors .....	00150.55
Railway Work .....	00170.01(e)
On-Site Work .....	00180.40(b)
Contract Completion Time .....	00180.50(h)
Right-of-Way and Access Delays .....	00180.65
Traffic Lane Restrictions .....	00220.40(e)
Special Events .....	00220.40(e)
In-water Work Restrictions .....	00290.34(a)
Noise Control .....	00290.32
Maintenance Under Traffic .....	00620.43
Opening Sections to Traffic.....	00744.51
Opening Sections to Traffic .....	00745.51

Be aware of and subject to schedule limitations in the Standard Specifications that are not listed in this Subsection.

**00180.41 Project Work Schedules** – Add the following:

A Type B schedule as detailed in the Supplemental Specifications is required on this Contract. In addition, a three-week look ahead schedule shall be prepared by the Contractor on a weekly basis and submitted to the Engineer. It shall include all construction activities planned for the following three-week period. The three-week look ahead schedule can be hand-written and shall be in a format agreed upon by the Contractor and the Engineer.

**The Contractor shall notify the County 2 weeks before the first substantial work activity commences on the project site. When the contract schedule of bid items does include Portable Change Message Signs, Portable Changeable Message Signs shall be in place 2 weeks before the first substantial work activity commences on the project site.**

**00180.42 Preconstruction Conference** - Add the following:

Before beginning On-Site Work and before meeting with the Engineer for the preconstruction conference, hold a group utilities scheduling meeting with representatives from the utility companies involved with this project. Incorporate the utilities time needs into the Contractor's schedule submitted prior to the preconstruction conference.

Submit the following during the preconstruction conference unless otherwise directed:

- The names, addresses, and telephone numbers of two or more persons employed by the Contractor who can be reached day or night to handle emergency matters.
- Subcontractor's list including contact list for each subcontractor with phone numbers and addresses and work to be performed.
- List of personnel authorized to sign change orders and receive progress payment warrants.
- Video recording of private properties affected by construction per 00150.70. A representative of each subcontractor shall be required to attend the pre-construction conference.

**00180.43 Commencement and Performance of Work** - Add the following bullet item:

- Conduct the work at all times in a manner and sequence that will insure minimal interference with traffic. The Contractor shall not begin work that will interfere with work already started. If it is in the County's best interest to do so, the County may require the Contractor to finish a portion or unit of the project on which work is in progress or to finish a construction operation before work is started on an additional portion or unit of the project.
- **The Contractor shall notify the County 2 weeks before the first substantial work activity commences on the project site.**
- **When the contract schedule of bid items does include Portable Changeable Message Signs, Portable Changeable Message Signs shall be in place 2 weeks before the first substantial work activity commences on the project site.**
- Conduct the work at all times in a manner and sequence that will insure minimal interference with traffic. The Contractor shall not begin work that will interfere with work already started. If it is in the County's best interest to do so, the County may require the Contractor to finish a portion or unit of the project on which work is in progress or to finish a construction operation before work is started on an additional portion or unit of the project.
- The Contractor will be notified in writing of the specified date to commence work and will not begin work until receipt of this Notice to Proceed. Upon the commencement of grinding, tilling, grading or paving operations on any one respective work site, all necessary work including paving of driveways and road approaches shall be vigorously pursued to reach substantial completion within a 14 calendar day duration. **If at any time a work site is left prior to substantial completion (completed paving of driveways, road approaches, etc.) without written consent from the owner's project manager, this will be considered abandonment by the Contractor.** Failure to meet these time constraints or abandonment shall subject the contractor to the full amount of Liquidated Damages as detailed in Section 00180.50 of these Special Provisions.
- At the time Substantial Completion is reached, the Contractor shall submit a Notice of Substantial Completion.

Add the following subsection:

**00180.50(h) Contract Time** - Complete all Work to be done under the Contract not later than September 1, 2022.

**00180.70 Suspension of Work** - Add the following to the first bullet item:

If the Inspector has reason to believe that any safety provisions are not being adhered to, the Inspector will immediately notify the Contractor's site foreman and/or the appropriate person and the County Project Manager. The purpose of this discussion is to determine the validity of

the alleged violation. This will also allow the Contractor a reasonable amount of time to correct or improve any of the provisions for the safety on this project. If the County Project Manager finds the problem still unresolved or uncorrected, they will notify the Contractor's Project Manager and the County's Risk Management Safety Analyst. If the County's Risk Management Safety Analyst finds that the job site contains any unresolved safety issues they will take appropriate action up to and including suspension of the Contractor's operations on all or part of the Work.

**00180.85(b) Liquidated Damages** - Add the following paragraphs:

The liquidated damages for failure to complete the Work on time required by 00180.50(h) will be \$600 per Calendar Day \*.

\* Calendar Day amounts are applicable when the Contract time is expressed on the Calendar Day or fixed date basis.

Add the following subsection:

**00180.85(c) Lane Closures and Road Closures** - Lane closures and road closures beyond the limits specified will inconvenience the traveling public and will be a cost to the Agency.

**(1) Lane Closures** - It is impractical to determine the actual damages the Agency will sustain in the event traffic lanes are closed beyond the limits listed in 00220.40(e). Therefore, the Contractor shall pay to the Agency, not as a penalty, but as liquidated damages, \$500 per 15 minutes, or for a portion of 15 minutes, per lane, for any lane closure beyond the limits listed in 00220.40(e). In addition to the liquidated damages, all added cost for traffic control measures, including flagging, required to maintain the lane closures beyond the allowed time limits, will be at no additional cost to the Agency. The required traffic control measures will be as determined by the Engineer.

The Engineer will determine when it is safe to reopen lanes to traffic. Assessment of liquidated damages will stop when all lanes have been safely reopened. Any liquidated damages assessed under these provisions will be in addition to those listed in 00180.85(b).

**00180.85(e) Traffic Delays Beyond 20 Minutes** - Stopping or holding vehicles beyond the limits specified will inconvenience the traveling public and will be a cost to the Agency.

It is impractical to determine the actual damages the Agency will sustain in the event traffic is stopped or held longer than the 20-minute limit listed in 00220.02. Therefore, the Contractor shall pay to the Agency, not as a penalty, but as liquidated damages, \$500 per 20 minutes, or for a portion of 20 minutes, for stopping or holding traffic longer than 20 minutes. In addition to the liquidated damages, any added cost for traffic control measures, including flagging, required to stop or hold traffic beyond the 20-minute time limit, will be at no additional cost to the Agency. The required traffic control measures will be as determined by the Engineer.

Assessment of liquidated damages will stop when the Engineer determines that traffic is no longer stopped or held beyond the 20-minute limit. Any liquidated damages assessed under these provisions will be in addition to those listed in 00180.85(b).

**00180.90(a) Termination for Default** - In the paragraph that begins "Termination of the Contract for default...", add the following bullet to the end of the bullet list:

Has liquidated and delinquent debt owed to the State or any department or Agency of the County,

**END OF SECTION**

**Section 00190 – Measurement of Pay Quantities**

Comply with Section 00190 of the Standard Specifications modified as follows:

**00190.20(g) Agency-Provided Weigh Technician:** Replace subsection (g) with the following:

The Contractor must provide a weigh technician. The Agency will not provide one for the Contractor.

**END OF SECTION**

**Section 00195 – Payment**

Comply with Section 00195 of the Standard Specifications modified as follows:

**00195.10 Payment for Changes in Material Costs** - Delete and replace with the following:

No asphalt cement cost adjustment shall be used on this project.

**00195.12 Steel Material Price Escalation/De-Escalation Clause** – Add the following sentence:

No steel material price escalation/de-escalations shall be used on this project. There is no option for Contractor participation.

**00195.20(b) Significant Changed Work** - Replace the paragraph that begins “Any such adjustments...” with the following paragraph:

Any adjustments may be less than, but will not be more than the amount justified by the Engineer on the basis of the established procedures set out in Section 00197 for determining rates. This does not limit the application of Section 00199.

Significant is defined as:

- a) An increase or decrease of more than 25 percent of the total cost of the Work calculated from the original proposal quantities and the unit contract prices; or,
- b) An increase or decrease of more than 25 percent in the quantity of any one major contract item.

For condition b) above, a major item is defined as any item that amounts to 10 percent or more of the original total contract price.

**00195.50 Progress Payments and Retained Amounts** - Modify as follows:

**00195.50(a) Progress Payments** - Modify as follows:

**(1) Progress Estimates** - Delete the first sentence and replace with the following:

At a regular period each month to be determined at the Preconstruction Conference, the Contractor will make an estimate of the amount and value of pay item work completed and in place. This estimate will be submitted to the Project Manager for review and approval.

**(2) Value of Material on Hand** - Replace with the following:

**(2) Value of Material on Hand** - The Contractor will make an estimate of the amount and value of acceptable material to be incorporated in the completed work which has been delivered and stored as given in 00195.60(a) for review and approval.

**(4) Limitations on Value of Work Accomplished** - In the first sentence, change "Engineer's estimate" to "Contractor's reviewed estimate".

**00195.50 (b) Retainage** - Replace the first paragraph with the following:

The amount to be retained from progress payments will be 5.0% of the value of payments made, and will be retained in one of the forms specified in Subsection (c) below. The County will withhold Retainage from all force account and change order work.

**00195.50(c) Forms of Retainage** – Replace the first paragraph with the following:

Forms of acceptable retainage are set forth below in Subsections (1) through (3). "Cash, Alternate A" or "Cash, Alternate B" (Retainage Surety Bond) are the Agency-preferred forms of retainage. Unless the Contractor notifies the County otherwise in writing, the County will automatically hold retainage per paragraph (2) "Cash, Alternate B (No Interest Earned)". If the Agency incurs additional costs as a result of the Contractor's election to use "Bonds and Securities", the Agency may recover such costs from the Contractor by a reduction of the final payment.

Replace paragraph (2) with the following:

**(2) Cash, Alternate B (No Interest Earned)** – Retainage will be deducted from progress payments and held by the Agency until final payment is made in accordance with 00195.90, unless otherwise specified in the Contract.

**00195.50(d) Release of Retainage** – Replace with the following:

**(d) Release of Retainage** - As the Work progresses, release of the amounts to be retained under (b) of this Subsection will only be considered for Pay Items that have been satisfactorily completed. For purposes of this Subsection, a Pay Item will be considered satisfactorily completed only if all of the Work for the Pay Item is complete and all contractual requirements pertaining to the Pay Item and Work have been satisfied. Work not included in a Pay Item, or

which constitutes part of an uncompleted Pay Item, will not be regarded as satisfactorily completed Work for the purposes of this Subsection.

When the Work is 50% completed and upon written application of the Contractor and written approval of the Surety, the Engineer or Project Manager may reduce or eliminate retainage on remaining progress payments if the Work is progressing satisfactorily.

A determination of satisfactory completion of Pay Items or Work or release of retainage shall not be construed as acceptance or approval of the Work and shall not relieve the Contractor of responsibility for defective Materials or workmanship or for latent defects and warranty obligations.

#### **END OF SECTION**

#### **Section 00196 – Payment for Extra Work**

Comply with Section 00196 of the Standard Specifications modified as follows:

**00196.91 Extra Work Allowance** – Add the following section:

The Bid schedule of prices contains a bid item for a pre-determined amount of Engineer ordered extra work. All Bidders shall reflect this same amount in their total Bid. No Bidder shall presume in the preparation of the bid or in the course of contract work that there will be a certain payment under that item or a certain order for extra work.

#### **END OF SECTION**

#### **Section 00197 – Payment for Force Account Work**

Comply with Section 00197 of the Standard Specifications modified as follows:

**00197.20(a) General** - Replace the paragraph that begins "Except as modified by these..." with the following paragraph:

Except as modified by these provisions, Equipment use approved by the Engineer will be paid at the rental rates given in the most current edition of the EquipmentWatch Cost Recovery (Blue Book) published by EquipmentWatch, a division of Penton Business Media, Inc., and available from EquipmentWatch (phone 1-800-669-3282) (<http://equipmentwatch.com>).

#### **END OF SECTION**

## Section 00199 – Disagreements, Protests and Claims

Comply with Section 00199 of the Standard Specifications modified as follows:

**00199.40 Claim Decision; Review; Exhaustion of Administrative Remedies** - Replace the entire section with the following:

The Contractor must properly submit a claim as detailed in 00199.30.

**(a) Engineer Claim Review** - The Engineer or Project Manager will, as soon as practicable, consider and investigate a Contractor's properly submitted claim for additional compensation, Contract Time, or for a combination of additional compensation and Contract Time. Once the Engineer or Project Manager determines the Agency is in receipt of a properly submitted claim, the Engineer or Project Manager will arrange a meeting, within 28 Calendar Days, or as otherwise agreed by the parties, with the Contractor in order to present the claim for formal review and discussion. A person authorized by the Contractor to execute Change Orders on behalf of the Contractor must be present and attend all claim meetings.

If the Engineer or Project Manager determines that the Contractor must furnish additional information, records, or documentation to allow proper evaluation of the claim, the Engineer will schedule a second meeting, to be held within 14 calendar days, or as otherwise agreed by the parties, at which the Contractor shall present the requested information, records and documentation.

The Engineer or Project Manager will advise the Contractor of the decision to accept or reject the claim. If the Engineer or Project Manager finds the claim has merit, an equitable adjustment will be offered. If the Engineer or Project Manager finds the claim has no merit, no offer of adjustment will be made and the claim will be denied. The County intends to resolve claims at the lowest possible level.

If, at any step in the claim decision or review process, the Contractor fails to promptly submit requested information or documentation that the Agency deems necessary to analyze the claim, the Contractor is deemed to have waived its right to further review, and the claim will not be considered properly filed and preserved.

If the Engineer or Project Manager has denied a claim, in full or in part, for Contract Time only according to 00180.80, or has denied a claim, in full or in part, for correction of final compensation according to 00195.95, those disputed claims may then be resolved, in full or in part, at either of the two progressive steps of claim review procedure as specified in this Subsection. For all claims, all of the actions and review under each step of the review process shall occur before the review can be advanced to the next higher step.

**(b) Director Claim Review** - Upon request by the Contractor, the Department Director will review the Engineer or Project Manager's decision on the claim and advise the Contractor of the decision in writing. If the Director finds the claim has merit, and equitable adjustment will be offered. If the Director finds the claim has no merit, no offer of adjustment will be made and the claim will be denied.

Once the Engineer determines the Agency is in receipt of a properly submitted claim, the Engineer will arrange a meeting, within 21 Calendar Days or as otherwise agreed by the parties, with the Contractor in order to present the claim for formal review and discussion.

If the Engineer determines that the Contractor must furnish additional information, records or documentation to allow proper evaluation of the claim, the Engineer will schedule a second meeting, to be held within 14 Calendar Days or as otherwise agreed by the parties, at which the Contractor shall present the requested information, records and documentation.

The Director shall evaluate the claim based on the information provided by the Contractor to the Engineer or Project Manager. However, if the Department Director (or designee) determines that the Contractor must furnish additional information, records or documentation to allow proper evaluation of the claim, the Department Director (or designee) will schedule a meeting, to be held within 14 Calendar Days, or as otherwise agreed by the parties, at which the Contractor shall present the requested information, records and documentation.

The claim is subject to records review, if not all of the records requested by the Department Director (or designee) were furnished. If applicable, advancement of the claim is subject to the provisions regarding waiver and dismissal of the claim or portions of the claim.

The decision of the Department Director shall be the final decision of the Agency.

**(c) Commencement of Litigation** - If the Contractor does not accept the Director's decision, then the Contractor shall commence any suit or action to collect or enforce any claim filed in accordance with 00199.30 within a period of one (1) year following the mailing of the decision or within one (1) year following the date of "Second Notification", whichever is later. If said suit or action is not commenced in said one (1) year period, the Contractor expressly waives any **and** all claims for additional compensation and any and all causes of suit or action for the enforcement thereof that he might have had.

The Contractor must follow each step in order, and exhaust all available administrative remedies before resorting to litigation. Litigation of a claim that cannot be resolved through the process described above shall be initiated by filing a complaint in the Clackamas County Circuit Court for the State of Oregon.

In any litigation, the entire text of any order or permit issued by the County or any other governmental or regulatory authority, as well as any documents referenced or incorporated therein by reference, shall be admissible for purposes of Contract interpretation.

The Contract shall not be construed against either party regardless of which party drafted it. Other than as modified by the Contract, the applicable rules of contract construction and evidence shall apply. This Contract shall be governed by and construed according to the laws of the State of Oregon without regard to principles of conflict of laws.

The Contractor shall comply with 00170.00.

**00199.50 Mediation** - Delete the entire section.

**00199.60 Review of Determination Regarding Records** - Delete the entire section.

**END OF SECTION**



**SECTION 00210 - MOBILIZATION**

Comply with Section 00210 of the Standard Specifications modified as follows:

**00210.40 Mobilization** – add the following to the end of the bullet list:

- Property owners shall be notified at least 7 days prior to Work within the project area. Prior to commencing any work, the Contractor shall place a general project informational door hanger at each property within the project area. Content, appearance, and design will be provided to the Contractor by the County. All labor, materials, direct costs, and indirect costs associated with the project informational door hanger shall be included in "Door Hanger #1: General Project Information" lump sum bid item.
  
- Property owners shall be notified at least 48 hours prior to pavement paving work within the project area. Prior to commencing any work, the Contractor shall place a paving informational door hanger at each property within the project area. Content, appearance, and design will be provided to the Contractor by the County. All labor, materials, direct costs, and indirect costs associated with the project informational door hanger shall be included in "Door Hanger #2: Paving Information" lump sum bid item.

**00210.90 Payment** - Add the following Pay Item(s) to the Pay Items list:

- (a) Mobilization ..... Lump Sum
- (b) Door Hanger: Paving Information ..... Lump Sum

Payment for Mobilization will be made at the Contract lump sum amount for the Mobilization item and will include everything except (b).

Payment for Door Hanger will made on the progress payment after the Work for those bid items are complete. Partial payment won't be allowed for Door Hangers.

**END OF SECTION**

**SECTION 00220 - ACCOMMODATIONS FOR PUBLIC TRAFFIC**

Comply with Section 00220 of the Standard Specifications.

**END OF SECTION**

## **SECTION 00221 - COMMON PROVISIONS FOR WORK ZONE TRAFFIC CONTROL**

Comply with Section 00221 of the Standard Specifications modified as follows:

**00221.90(b) Temporary Protection and Direction of Traffic** - Delete the bullet that begins "Moving temporary barrier to and from Contractor's stockpile areas".

**END OF SECTION**

## **SECTION 00222 – TEMPORARY TRAFFIC CONTROL SIGNS**

Comply with Section 00222 of the Standard Specifications.

**END OF SECTION**

## **SECTION 00225 - TEMPORARY PAVEMENT MARKINGS**

Comply with Section 00225 of the Standard Specifications.

**END OF SECTION**

## **SECTION 00280 - EROSION AND SEDIMENT CONTROL**

Comply with Section 00280 of the Standard Specifications modified as follows:

**00280.06 Erosion and Sediment Control Manager** - Delete this subsection.

**00280.62 Inspection and Monitoring** - Replace this subsection, except for the subsection number and title, with the following:

Inspect the Project Site and all ESC devices for potential erosion or sediment movement on a weekly basis and when 1/2 inch or more of rainfall occurs within a 24-hour period, including weekends and holidays.

If a significant noncompliance or serious water quality issue occurs that could endanger health or the environment, verbally report it to the Engineer within 24 hours.

**00280.90 Payment** - In the paragraph that begins "Item (a) includes..." delete the bullet that specifies "providing the Erosion and Sediment Control Manager".

**END OF SECTION**

## **SECTION 00290 - ENVIRONMENTAL PROTECTION**

Comply with Section 00290 of the Standard Specifications.

**END OF SECTION**

## **SECTION 00305 - CONSTRUCTION SURVEY WORK**

Comply with Section 00305 of the Standard Specifications.

**END OF SECTION**

## **SECTION 00310 - REMOVAL OF STRUCTURES AND OBSTRUCTIONS**

Comply with Section 00310 of the Standard Specifications modified as follows:

**00310.90 Payment** - Add the following to the end of this subsection:

No separate or additional payment will be made for removal or disposal Work included in Section 00330 according to 00310.02.

**END OF SECTION**

## **SECTION 00330 – EARTHWORK**

Comply with Section 00330 of the Standard Specifications supplemented and/or modified as follows:

**00330.00 Scope** – Supplement this section with the following:

This work also includes removal of asphalt pavement, aggregate and subgrade to the top of proposed subgrade within the roadway prism as shown on the Plans.

**00330.41(a-6) Excavation of Existing Surfaces** – Add the following to this section:

Remove surfacings as shown on the Plans. Surfacings to be removed shall be sawcut in neat, straight lines with vertical edges along the limits of pavement removal. The cut lines for removal of asphaltic concrete pavement shall be favorably reviewed by the Engineer in the field before cutting. Remove pavement adjacent to the curb as shown on the Plans.

Take care not to disturb existing utilities when removing various types of pavement. If existing utilities are found to be in conflict with the proposed improvements, notify the Engineer immediately. Repair utilities damaged during pavement removal at no cost to the Contracting Agency.

**00330.43(c) Non-Moisture-Density Testable Materials** – Supplement this section with the following:

The native roadway subgrade or aggregate base surface shall be approved by the Engineer prior to placing any fill, base rock or ACP layers. Onsite proof roll deflection tests shall be performed with a 20,000 lb. vehicle and must be performed and witnessed as directed by the Engineer. No deflection is allowed and all pavement areas shall be tested. During wet weather construction (as approved by the Engineer), provide the proof-roll test over the base rock surfaces prior to placement of any pavement.

**00330.80 Measurement** - Replace this section with the following:

No measurement will be made under this section and all work performed shall be considered incidental to other bid items.

**00330.90 Payment** - Replace with the following:

No payment will be made under this section and all work performed shall be considered incidental to other bid items.

#### **END OF SECTION**

#### **SECTION 00331 - SUBGRADE STABILIZATION**

Comply with Section 00331 of the Standard Specifications.

#### **END OF SECTION**

#### **SECTION 00480 - DRAINAGE CURBS**

Comply with Section 00480 of the Standard Specifications.

#### **END OF SECTION**

#### **SECTION 00610 – RECONDITIONING EXISTING ROADWAY**

Comply with Section 00610 of the Standard Specifications modified as follows:

**00610.00 Scope** – Supplement this subsection with the following:

If existing paved surfaces and bases are to be excavated and removed, the performance, measurement, and payment of the Work will be according to Sections 00310 and 00330 as indicated in the Contract Schedule of Items.

**00610.42 Aggregate Subbase, Base and Surfacing** – Supplement this subsection with the following:

Finish the surface to the necessary grade which establishes a smooth and driveable surface free from bumps, humps or other vertical abnormalities. Establish positive drainage which matches or improves the existing conditions of the site prior to grading. Grading shall be approved by the Engineer prior to paving.

Add the following section:

**00610.44 Protect Existing Subgrade** – The Contractor shall protect the existing roadway base and subgrade from damage following asphalt pavement removal. Protection will include limiting all construction activities that could damage either exposed or aggregate base covered subgrade such as continued loading with construction equipment as part of haul routes for other work, continued loading during periods with inclement weather or as part of hauling operations that could compromise subgrade soils and all other activities within control of the Contractor. The Contractor shall protect subgrades from excessive moisture after pavement removal. Preventative measures shall be utilized to protect the subgrade during forecasted precipitation. Any damage to the subgrade as a result of the Contractors negligence shall be repaired at the Contractors expense.

The Contractor shall prepare and submit a subgrade protection plan that identifies the Contractors intended means and methods of removing existing surfaces, constructing new subgrade surfaces as prescribed in the Contract Documents, and protecting the existing subgrade from potential damage by the Contractors operations or outside factors such as weather. The Contractor shall be responsible to phase all work that places construction loads directly on the existing subgrade and select equipment sizes and classes in an effort to minimize potential overloading of the existing subgrade. If the Contractor's plan includes running haul equipment on exposed subgrades or aggregate covered subgrades, the haul equipment shall be limited to half of the maximum load.

**00610.80 Measurement** – Replace this subsection, except for the number and title, with the following:

The quantities of finishing roadbeds will be measured on the area basis, computed by multiplying the length of the roadway by the width of the roadbed actually graded, compacted, and finished as accepted by the Engineer.

**00610.90 Payment** – Replace this subsection, except for the number and title, with the following:

Pay Item	Unit of Measurement
(a) Reconditioning Existing Roadway.....	Square Yard

Payment will be payment in full for furnishing all Materials, Equipment, labor, and Incidentals necessary to complete the Work as specified.

Item (a) includes all labor, equipment and materials necessary to trim, shape, finish, compact and proof-roll the roadway in preparation for new asphalt concrete pavement placement. Payment also includes all materials, equipment and labor necessary to protect the subgrade from damage prior to and during new asphalt concrete pavement construction.

No additional pavement will be made for additional grading necessary to re-establish existing drainage patterns, improve drainage patterns as noted on the plans or provide a smooth and driveable roadway free of ruts, depressions and irregularities.

#### **END OF SECTION**

### **SECTION 00620 - COLD PLANE PAVEMENT REMOVAL**

Comply with Section 00620 of the Standard Specifications.

#### **END OF SECTION**

### **SECTION 00730 - EMULSIFIED ASPHALT TACK COAT**

Comply with Section 00730 of the Standard Specifications modified as follows:

**00730.11 Emulsified Asphalt** - In the paragraph that begins "Obtain samples according to AASHTO T 40..." replace the words "AASHTO T 40" with the words "AASHTO R 66".

### **SECTION 00744 - ASPHALT CONCRETE PAVEMENT**

**00744.11(a) Asphalt Cement** - Add the following to the end of this subsection:

Provide PG 64-22. grade asphalt cement for this Project.

**00744.16 Sampling and Testing** - Replace this subsection, except for the subsection number and title, with the following:

For each road, have a CAT I perform a minimum of one of each of the following test methods as modified in the MFTP:

Asphalt Content - AASHTO T 308 with ODOT TM 323 determined Calibration Factor

- Gradation - AASHTO T 30
- Mix Moisture - AASHTO T 329
- Maximum Specific Gravity - AASHTO T 209
- Field Compacted Gyratory Specimens - ODOT TM 326

When less than 1,000 Tons of mix is placed in a Day, perform a minimum of one series of tests per Day. Provide test results to the Engineer by the middle of the following work shift. The Engineer may waive the requirement for any of AASHTO T 308, AASHTO T 30, AASHTO T 329, and ODOT TM 326 on a daily basis. The Engineer may waive the requirement for AASHTO T 209 when less than 500 Tons of ACP is placed in a single work shift.

Provide samples or split samples to the Engineer when requested.

**00744.17 Acceptance** - Replace this subsection, except for the subsection number and title, with the following:

If the test result for each mix gradation constituent, asphalt content, and density measurement is within the specification limits, the material will be accepted. If the asphalt content, one or more gradation constituents, or the density measurement are not within the specification limits, the material that is not within the specification limits will be accepted according to 00150.25.

**00744.41 Mixing Temperature** - Replace the table with the following:

Type	Temperature, °F	
	Maximum at Mixer	Minimum Behind Paver
HMAC	350	240
WMAC	350	215

**00744.42 Preparation of Underlying Surfaces** – replace with the following:

**(a) Tack Coat** – Construct a tack coat before placing each lift of ACP according to Section 00730. A tack coat is not required before placing ACP on Aggregate Base.

Remove all loose material will reduce adhesion of the tack by brooming, flushing with water, or to section 00730. Before applying the tack coat, clean, and dry the surface to be tacked.

Treat all waterproofing membranes on and against which ACP is to be placed with an asphalt tack coat meeting the requirements of 00744.11(a) or as recommended by the membrane manufacturer.

**(b) Overlay Preparation** - Existing pavement surfaces shall be cleaned of all loose material, dirt and dust by brooming, by flushing with water or other approved methods prior to applying the tack coat or pavement overlay fabric. Any grass or other vegetation between the existing asphalt concrete and the curb shall be totally removed. Any vegetation that exists over the face of the curb line shall be removed in a neat workman like manner. The existing curb shall be cleaned and a tack coat applied prior to paving.

**NOTE: The contractor is responsible for street sweeping. Special attention will be given to organic materials in cracks and the removal of all materials on the edge of the existing pavement. The contractor shall use vacuum sweepers that are self-propelled equipped**

**with rotating brooms and brushes that are capable of loosening dirt and debris from the road surface and collecting the material by vacuum device**

All work required in the cleaning and preparing the work site as described above and payment for this item shall be considered incidental to and included in the unit price for asphalt concrete material, and no additional compensation shall apply.

**(c) Pre-Leveling Courses** - Existing pavements have occasional surface irregularities and uneven crown section. In these worst cases, it is the intent that this condition be corrected through the means of application of an asphalt concrete leveling course prior to the placing of the uniform 2" wearing course overlay. In leveling irregular surfaces, the presence of low areas and the surface grade to which the final course is to be placed may require the asphalt mixture to be laid in two or more layers in which case the compacted thickness of any one layer shall not exceed two and one-half (2 ½) inches.

All pre-leveling work must be performed at the direction of the County and quantities identified on the schedule of prices are approximate.

Asphalt concrete mixture to achieve the necessary pre-leveling work will be paid on the contract unit price per ton for the respective work site schedule of prices.

**00744.49 Compaction** - Replace the paragraph that begins "Determine compliance with..." with the following paragraph:

Determine compliance with density Specifications by random testing of the compacted surface with calibrated nuclear gauges. Determine the density by averaging QC tests performed by a CDT with the nuclear gauge operated in the backscatter mode according to AASHTO T 355 at one random location for each 100 Tons of asphalt concrete placed, but take no less than 10 tests each shift. Do not locate the center of a density test less than 1 foot from the Panel edge. Calculate MAMD according to ODOT TM 305. The Engineer may waive compaction testing requirements when less than 500 Tons of ACP is placed in a single work shift.

**00744.51 Opening Sections to Traffic** - Schedule work so that, during the same shift, the surfaces being paved are paved full width and length through the wearing Course before opening to traffic.

**00744.80 Measurement** - Add the following paragraph to the beginning of this subsection:

The quantities of ACP shown in the Contract Schedule of Items were computed on the basis of aggregates having a Specific Gravity of 2.463.

**END OF SECTION**

## **SECTION 00748 - ASPHALT CONCRETE PAVEMENT REPAIR**

Comply with Section 00748 of the Standard Specifications.

**END OF SECTION**



**SECTION 00749 - MISCELLANEOUS ASPHALT CONCRETE STRUCTURES**

Comply with Section 00749 of the Standard Specifications.

**END OF SECTION**

**SECTION 00850 - COMMON PROVISIONS FOR PAVEMENT MARKINGS**

Comply with Section 00850 of the Standard Specifications.

**END OF SECTION**

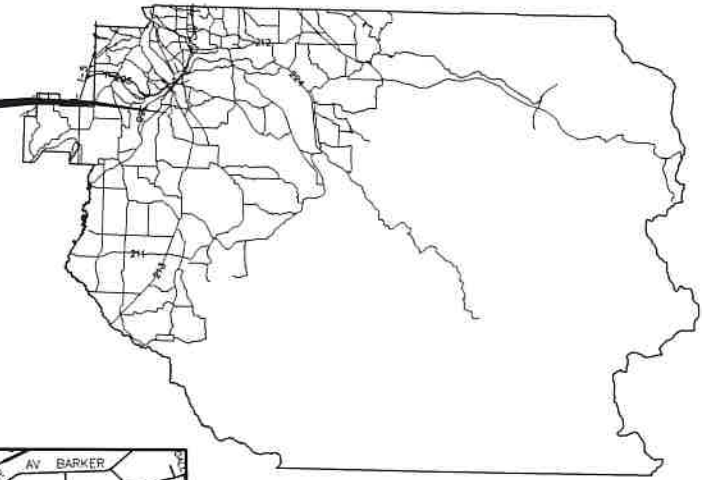
**SECTION 00867 - TRANSVERSE PAVEMENT MARKINGS - LEGENDS AND BARS**

Comply with Section 00867 of the Standard Specifications.

**END OF SECTION**

# CLACKAMAS COUNTY DEPARTMENT OF TRANSPORTATION AND DEVELOPMENT

PLANS FOR PROPOSED PROJECT  
PAVING, GRINDING, AND GRADING  
**SALMONBERRY DRIVE  
LOCAL PAVING PROJECT  
2022 PAVEMENT PRESERVATION**



INDEX OF SHEETS		
1	COVER SHEET	
2	TYPICAL SECTIONS	
3	ACP DETAILS	
4	STRIPING DETAILS	
5	PLAN SHEETS	SALMONBERRY DR.
6	PLAN SHEETS	SALMONBERRY DR./COLUMBINE CT.

COVER  
SALMONBERRY DR.  
LOCAL PAVING  
PROJECT

DATE: 6/12/21 PROJECT NO.:

CLACKAMAS COUNTY  
DEPT. OF TRANSPORTATION  
AND DEVELOPMENT  
150 BEAVERCREEK ROAD  
OREGON CITY, OR 97045

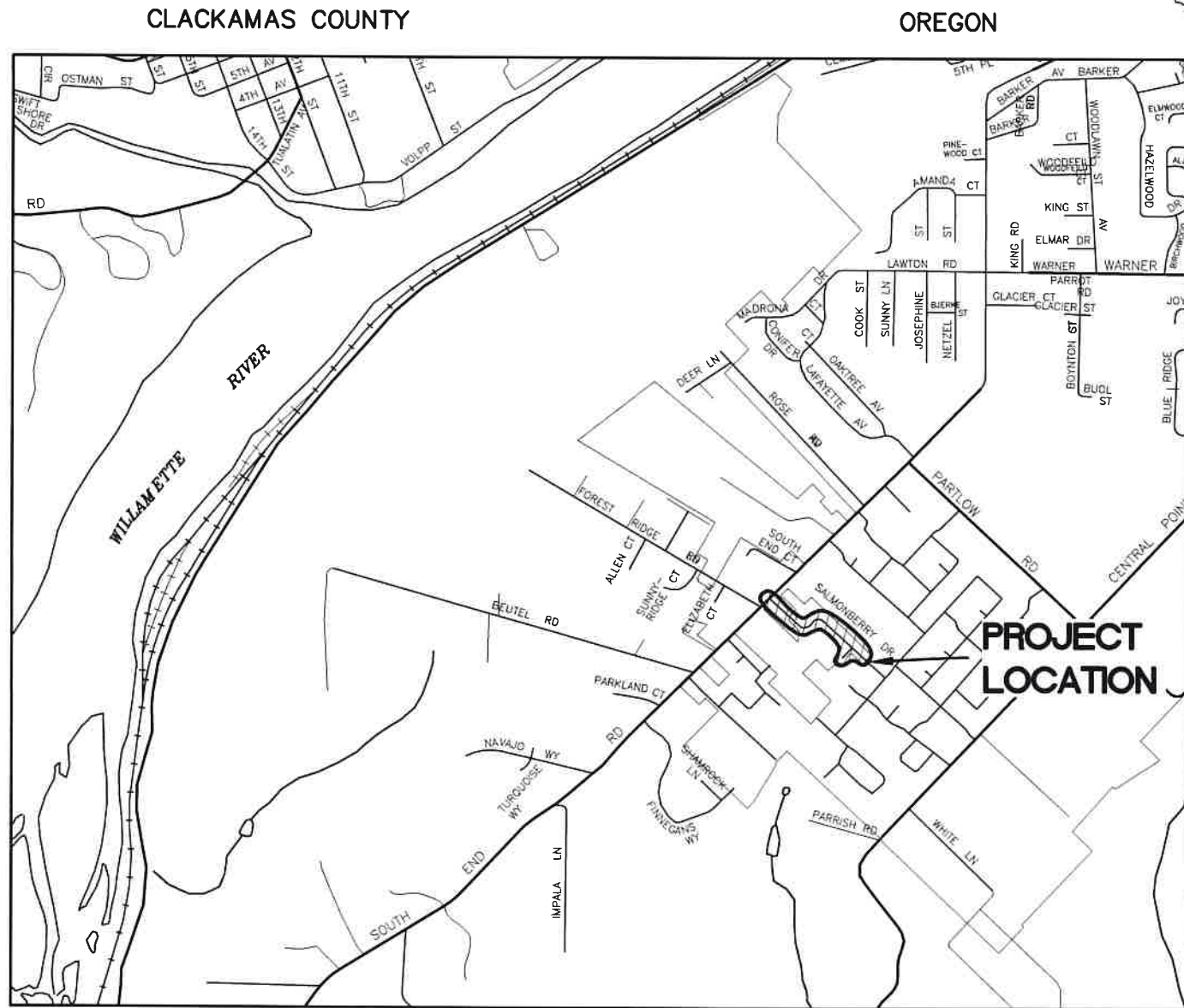


DIRECTOR  
DAN JOHNSON

DESIGNED BY: VH  
DRAFTED BY: RM  
CHECKED BY: STAFF

REVISIONS	NOT DATE:

Sheet No. 1



**RIGHT-OF-WAY REPRESENTATION:**

ALL LINE-WORK SHOWN RELATING PROPERTY BOUNDARY TO SCAN DATA IS FOR GRAPHICAL REPRESENTATION ONLY. ANY APPARENT DISCREPANCIES BETWEEN SAID DATA WILL REQUIRE FIELD VERIFICATION THROUGH A PROPER RIGHT-OF-WAY RESOLUTION.

**ATTENTION !**

OREGON LAW REQUIRES YOU TO FOLLOW RULES ADOPTED BY THE OREGON UTILITY NOTIFICATION CENTER. THOSE RULES ARE SET FORTH IN OAR 952-001-0010 THROUGH OAR 952-001-0100. YOU MAY OBTAIN COPIES OF THE RULES FROM THE CENTER OR ANSWERS TO QUESTIONS ABOUT THE RULES BY CALLING (503) 232-1987.

VICINITY MAP  
NOT TO SCALE



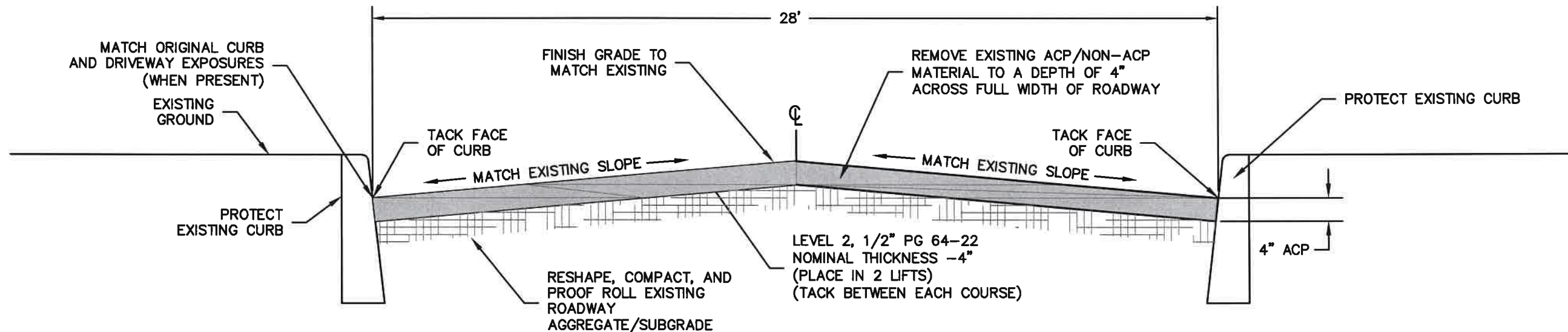
T. 3S, R. 1E, SEC. 12



RENEWAL DATE: 6/30/2023

K:\V\UNIT KU BY NAME\SALMONBERRY\_DK\_31062\2021 PAVING PLANS LOCAL AREA\SALMONBERRY LOCAL PAVING PLANS.UWG 4/18/2021 2:26 PM

K:\UNIT RD BY NAME\SALMONBERRY\_DR\_31062\2021 PAVING PLANS\LOCAL PAVING PLANS\LOCAL PAVING PLANS.DWG 4/18/2021 2:26 PM



**ACP RECONSTRUCTION DETAIL**

NTS

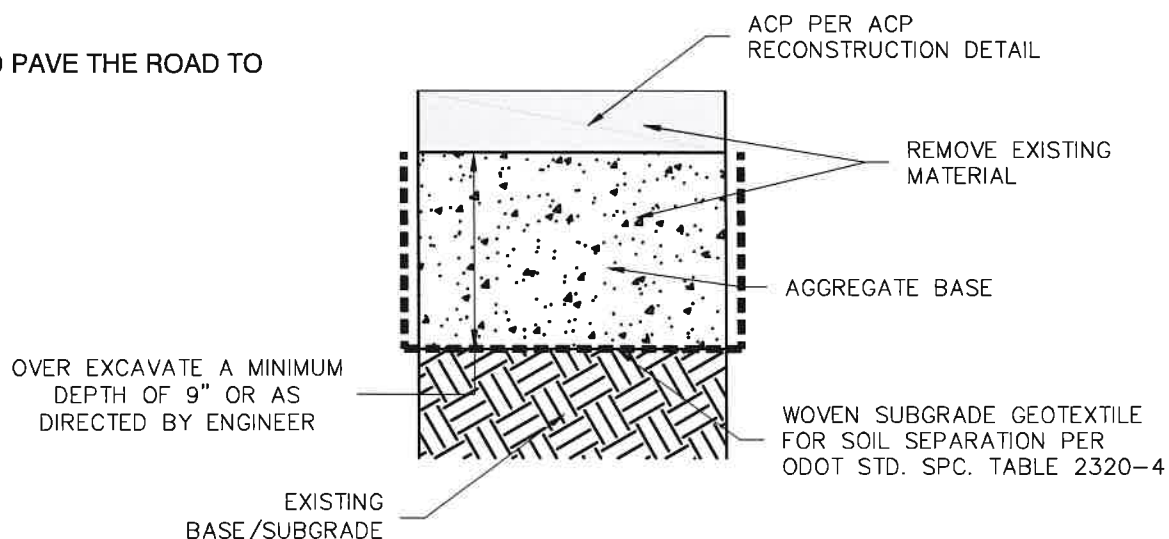
**SURFACE REMOVAL, GRADING AND PAVING GRADE NOTES:**

1. ALL WORK SHALL OCCUR BETWEEN JULY 1 AND SEPTEMBER 30
2. WHERE PAVEMENT IS TO BE REPLACED TO EXISTING GRADE AT THE CROWN AND ADJACENT TO CURB, THE CONTRACTOR SHALL:
  - \* MARK EXISTING CURB FLOWLINE WITH PAINT PRIOR TO REMOVAL OF AC
  - \* SURVEY THE EXISTING ROADWAY CROWN, GRADE BREAKS, EDGE OF PAVEMENT AND OTHER LOCATIONS AS NECESSARY TO RE-ESTABLISH ROAD GRADES. EXISTING ELEVATIONS SHALL BE COLLECTED AT A MAXIMUM DISTANCE OF 25' WITHIN THE PROJECT LIMITS
3. SURVEY INFORMATION SHALL BE USED AS NECESSARY TO PAVE THE ROAD TO EXISTING GRADES AND ELEVATIONS.

**ODOT STANDARD DRAWINGS**

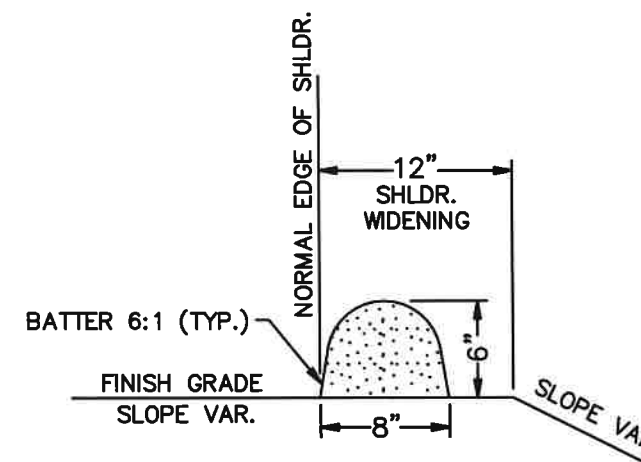
- RD 610
- RD 1010
- TM 503
- TM 800
- TM 821
- TM 822
- TM 850

TABLE 1		EXISTING ASPHALT DEPTH	EXISTING ROCK DEPTH
STREET NAME	STREET WIDTH	(PER CORES)	(PER CORES)
SALMONBERRY DR.	26'-40'	2.75"-4"	3"-4"
COLUMBINE CT.	26'-80'	2.75"-4"	3"



**SUBGRADE STABILIZATION SECTION**

NTS



**DRAINAGE CURB, STANDARD**

ON DENSE GRADED A.C.



TYPICAL SECTIONS  
SALMONBERRY DR.  
LOCAL PAVING  
PROJECT

CLACKAMAS COUNTY  
DEPT. OF TRANSPORTATION  
AND DEVELOPMENT  
150 BEAVERCREEK ROAD  
OREGON CITY, OR 97045



DIRECTOR

DAN JOHNSON

DATE: 8/12/2021 PROJECT NO.:

DESIGNED BY: VH  
DRAFTED BY: RM  
CHECKED BY: STAFF

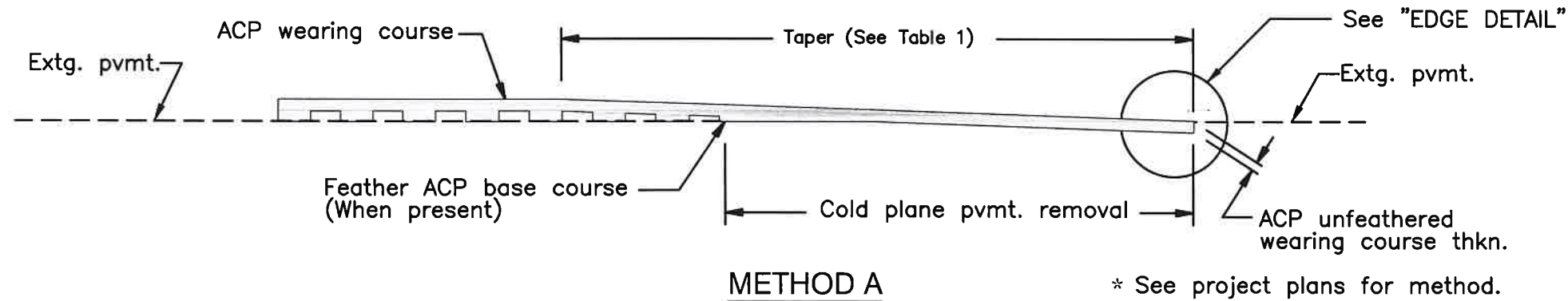
REVISIONS

NO DATE:

Sheet No.

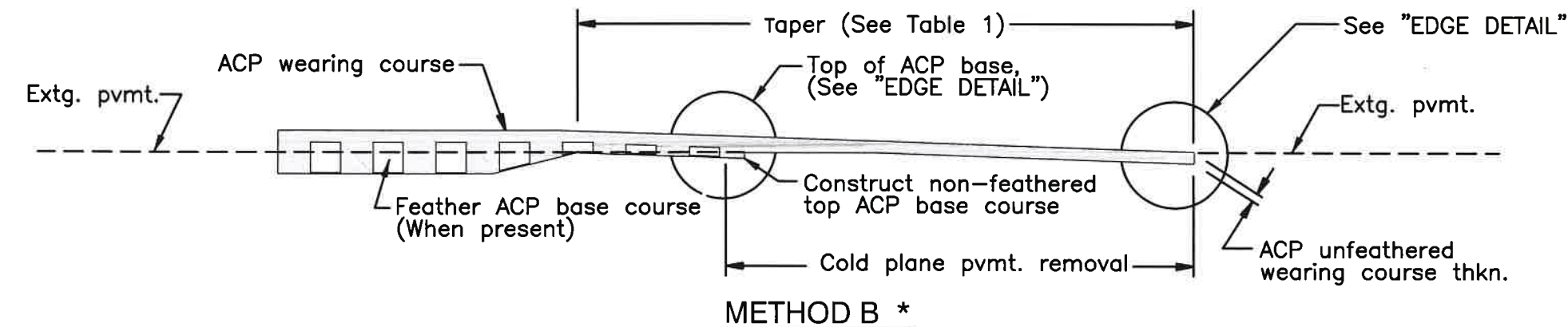


K:\UNIT RD BY NAME\SALMUNBERRY\_DK\_31002\ZUZ1 PAVING PLANS\LOCAL AREA\SALMUNBERRY LOCAL PAVING PLANS.DWG 4/18/2012 2:26 PM

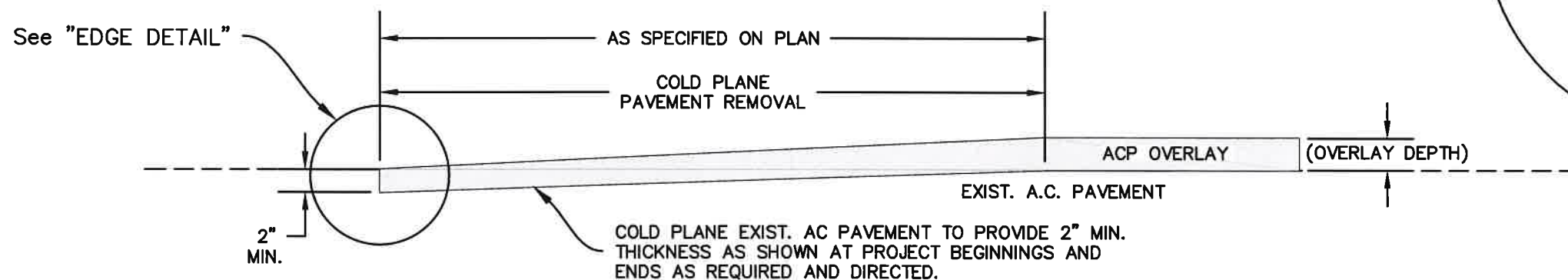
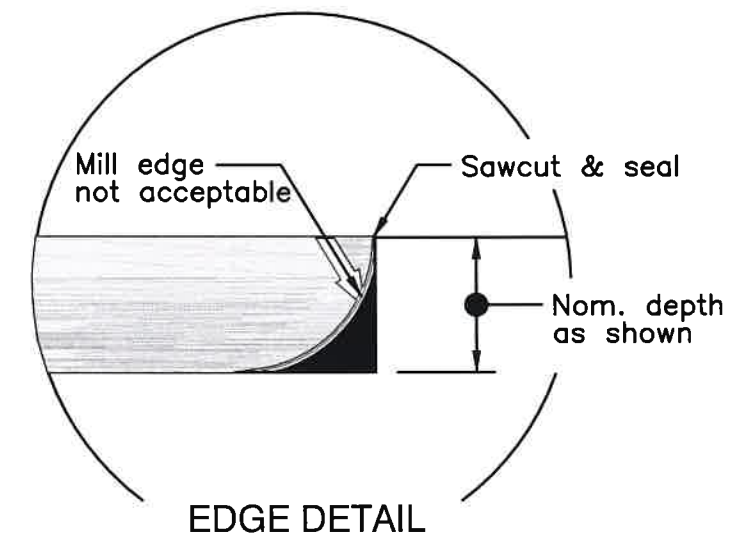


**TABLE 1**  
**TAPER LENGTHS**

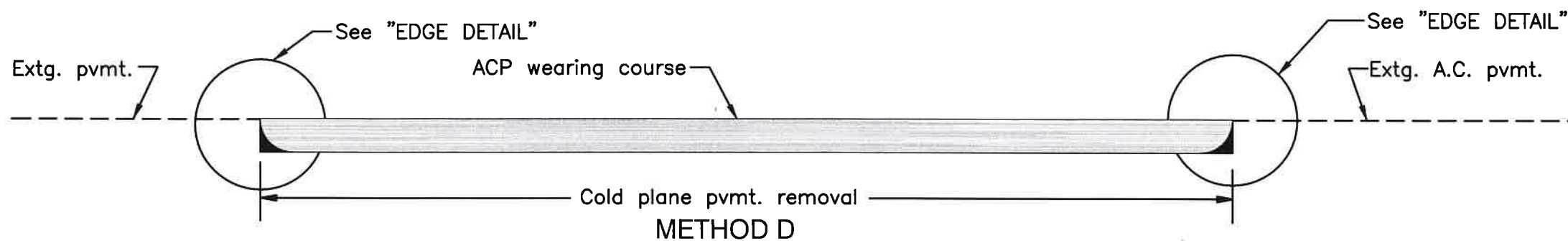
Posted Speed	Taper Length
< 45 mph	1" per 50'
≥ 45 mph	1" per 100'



**ACP PAVEMENT MATCH AT PROJECT ENDS OR BRIDGE ENDS  
WHEN NOT OVERLAYING THE BRIDGE**



**METHOD C  
OVERLAY TRANSITION (BUTT GRIND)**



**METHOD D  
METHOD OF MATCHING EXTG. ACP INLAY SURFACING  
(Inlay to extg. asphalt conc. pvmt.)**



**ACP DETAILS**  
**SALMUNBERRY DR.**  
**LOCAL PAVING PROJECT**  
 DATE: 8/12/2021 PROJECT NO.:

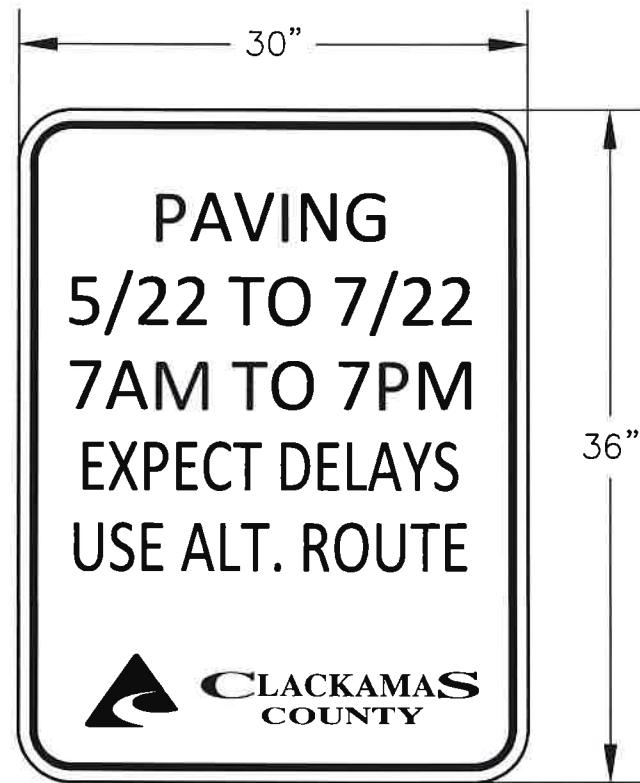
**CLACKAMAS COUNTY**  
 DEPT. OF TRANSPORTATION AND DEVELOPMENT  
 150 BEAVERCREEK ROAD  
 OREGON CITY, OR 97045  
**DAN JOHNSON**  
 DIRECTOR

DESIGNED BY: VH  
 DRAFTED BY: RM  
 CHECKED BY: STAFF

**REVISIONS**

NO	DATE	DESCRIPTION

K:\UNIT KU BY NAME \SALMUNBERTY DR\_31062\ZUZ1 PAVING PLANS LOCAL AREA \SALMUNBERTY LOCAL PAVING PLANS.DWG 4/18/2021 2:28 PM



SIGN



SIGN

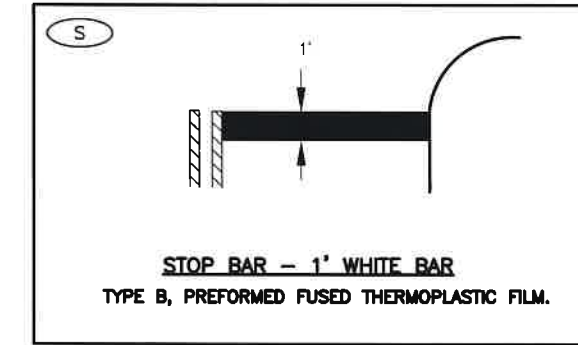
PROJECT SIGNS

1. SIGNS TO BE ORANGE BACKGROUND WITH BLACK LETTERING AND BORDERS.
2. SIGN LETTERING FONT TO BE F.H.W.A.C. CHARACTERS TO BE 4" HIGH
3. COUNTY LOGO TO COMPLY WITH COUNTY BRAND GUIDE : <http://web.clackamas.us/pgs/logo.html#guide>



SIGN TO BE PLACED AT EACH DRIVEWAY APPROACH WHEN PILOT CAR IS USED

SIGN SHALL CONFORM TO ODOT DRAWING CR4-20 OR CR4-20A



CONSTRUCTION PHASING NOTES:

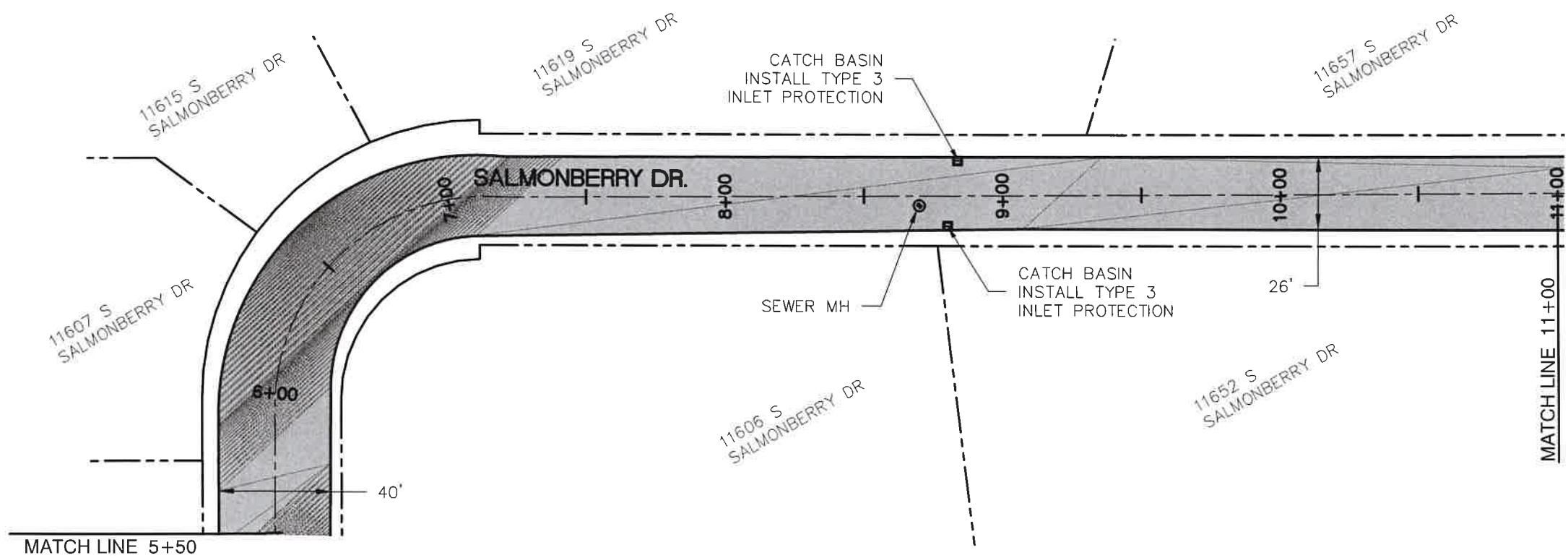
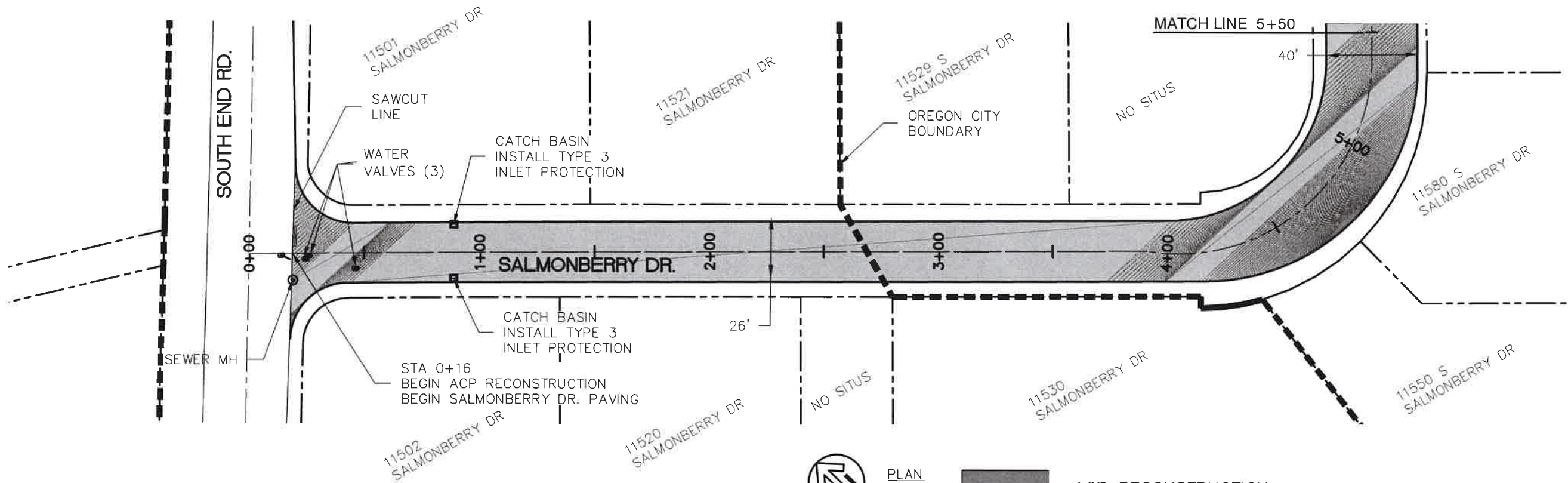
1. ALL WORK SHALL OCCUR BETWEEN JULY 1 AND SEPTEMBER 30
2. CONTRACTOR SHALL PREPARE DETAILED CONSTRUCTION PHASING AND TEMPORARY TRAFFIC CONTROL PLANS (FOR EACH STREET) THAT CONFORM THE LATEST EDITION OF M.U.T.C.D. AND CONTRACT DOCUMENTS FOR APPROVAL 14 CALENDAR DAYS BEFORE BEGINNING CONSTRUCTION ACTIVITIES.
3. CONTRACTOR SHALL FOLLOW APPROVED TRAFFIC CONTROL AND CONSTRUCTION PHASING PLANS.
4. ANY PROPOSED CHANGE TO THE CONSTRUCTION PHASING PLANS SHALL BE APPROVED IN WRITING BEFORE COMMENCING WORK ON THE PHASE AFFECTED BY THE PROPOSED CHANGE.
5. CONTRACTOR SHALL PHASE CONSTRUCTION SO THAT TRUCKING AND HEAVY CONSTRUCTION MANEUVERING IS COMPLETED ON A PAVED SURFACE (EXISTING OR NEW). THIS WILL BE ACCOMPLISHED BY ONLY HAVING HALF THE ASPHALT FROM THE ROADWAY REMOVED AT A TIME AND USING THE PAVED HALF TO FACILITATE HAIL TRUCKS. ANY DAMAGE TO THE SUBGRADE CAUSED BY THE CONTRACTOR PLACING TRUCKS ON THE UNPAVED SURFACES SHALL BE REPAIRED AT THE CONTRACTOR'S EXPENSE.



<p><b>CLACKAMAS COUNTY</b> DEPT. OF TRANSPORTATION AND DEVELOPMENT 150 BEAVERCREEK ROAD OREGON CITY, OR 97045</p> <p>DAN JOHNSON DIRECTOR</p>	<p><b>STRIPING DETAIL</b> SALMONBERRY DR. LOCAL PAVING PROJECT</p> <p>DATE: 8/12/2021 PROJECT NO.:</p>									
<p>DESIGNED BY: VH</p> <p>DRAFTED BY: RM</p> <p>CHECKED BY: STAFF</p>	<p>REVISIONS</p> <table border="1" style="width: 100%; border-collapse: collapse;"> <tr> <td style="width: 10%;">NO</td> <td style="width: 10%;">DATE:</td> <td style="width: 80%;"> </td> </tr> <tr> <td> </td> <td> </td> <td> </td> </tr> <tr> <td> </td> <td> </td> <td> </td> </tr> </table>	NO	DATE:							
NO	DATE:									
<p>Sheet No. 4</p>										



K:\VUNIT KU BY NAME\SALMONBERRY\_DR\_31002\ZUZU PAVING PLANS LOCAL AREA\SALMONBERRY LOCAL PAVING PLANS.DWG 4/18/2021 2:28 PM



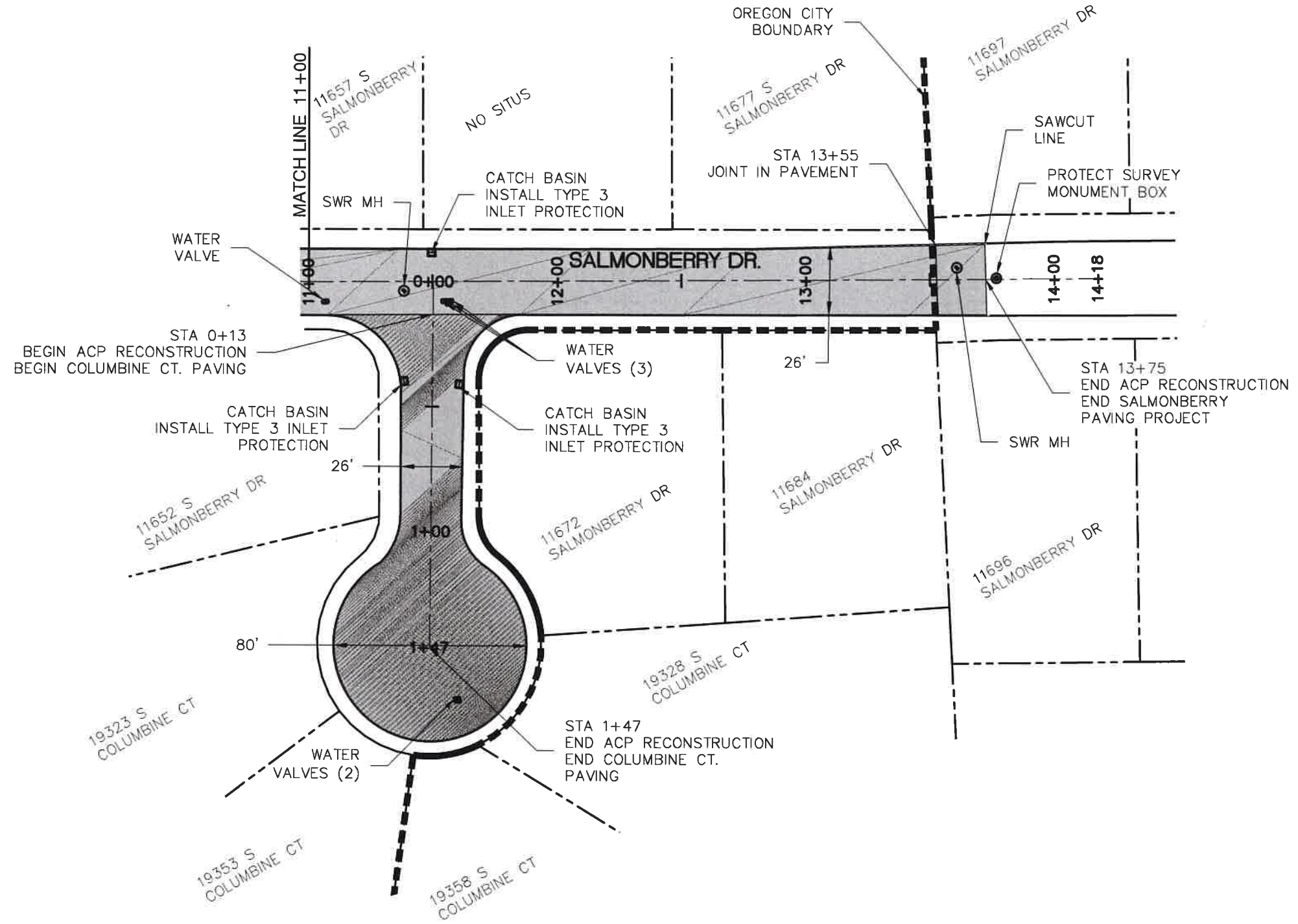
PLAN  
SALMONBERRY DR.  
LOCAL PAVING  
PROJECT

CLACKAMAS COUNTY  
DEPT. OF TRANSPORTATION  
AND DEVELOPMENT  
150 BEAVERCREEK ROAD  
OREGON CITY, OR 97045

DIRECTOR  
DAN JOHNSON

DESIGNED BY: VH	DRAFTED BY: RM	CHECKED BY: STAFF
REVISIONS		
NO DATE:		
Sheet No.	5	

DATE: 8/12/2021  
PROJECT NO.:



PLAN  
1"=50'



ACP RECONSTRUCTION



RENEWAL DATE: 6/30/2023


DESIGNED BY:	VH
DRAFTED BY:	RM
CHECKED BY:	STAFF

REVISIONS

NO DATE:				

Sheet No.

**CLACKAMAS COUNTY**  
DEPT. OF TRANSPORTATION  
AND DEVELOPMENT  
150 BEAVERCREEK ROAD  
OREGON CITY, OR 97045



DAN JOHNSON  
DIRECTOR

PLAN

**SALMONBERRY DR.  
LOCAL PAVING  
PROJECT**

DATE: 6/12/2021 PROJECT NO.:



# CERTIFICATE OF LIABILITY INSURANCE

DATE (MM/DD/YYYY)

4/19/2022

THIS CERTIFICATE IS ISSUED AS A MATTER OF INFORMATION ONLY AND CONFERS NO RIGHTS UPON THE CERTIFICATE HOLDER. THIS CERTIFICATE DOES NOT AFFIRMATIVELY OR NEGATIVELY AMEND, EXTEND OR ALTER THE COVERAGE AFFORDED BY THE POLICIES BELOW. THIS CERTIFICATE OF INSURANCE DOES NOT CONSTITUTE A CONTRACT BETWEEN THE ISSUING INSURER(S), AUTHORIZED REPRESENTATIVE OR PRODUCER, AND THE CERTIFICATE HOLDER.

**IMPORTANT:** If the certificate holder is an ADDITIONAL INSURED, the policy(ies) must have ADDITIONAL INSURED provisions or be endorsed. If SUBROGATION IS WAIVED, subject to the terms and conditions of the policy, certain policies may require an endorsement. A statement on this certificate does not confer rights to the certificate holder in lieu of such endorsement(s).

<b>PRODUCER</b> Anchor Insurance and Surety, Inc PO Box 2808 Portland OR 97208	<b>CONTACT NAME:</b> Kim Lee <b>PHONE (A/C, No, Ext):</b> 503-224-2500 <b>E-MAIL ADDRESS:</b> klee@anchorias.com		<b>FAX (A/C, No):</b> 503-224-9830
	<b>INSURER(S) AFFORDING COVERAGE</b>		
<b>INSURED</b> S-2 Contractors, Inc. 6860 S Anderson Road Aurora OR 97002	S-2CONT-01	<b>INSURER A :</b> BITCO General Insurance Corp.	<b>NAIC #</b> 20095
		<b>INSURER B :</b> SAIF Corporation	36196
		<b>INSURER C :</b> Travelers Indemnity Co. of Am.	25666
		<b>INSURER D :</b> Evanston Insurance Company	35378
		<b>INSURER E :</b>	
		<b>INSURER F :</b>	

**COVERAGES**

CERTIFICATE NUMBER: 1869845060

REVISION NUMBER:

THIS IS TO CERTIFY THAT THE POLICIES OF INSURANCE LISTED BELOW HAVE BEEN ISSUED TO THE INSURED NAMED ABOVE FOR THE POLICY PERIOD INDICATED. NOTWITHSTANDING ANY REQUIREMENT, TERM OR CONDITION OF ANY CONTRACT OR OTHER DOCUMENT WITH RESPECT TO WHICH THIS CERTIFICATE MAY BE ISSUED OR MAY PERTAIN, THE INSURANCE AFFORDED BY THE POLICIES DESCRIBED HEREIN IS SUBJECT TO ALL THE TERMS, EXCLUSIONS AND CONDITIONS OF SUCH POLICIES. LIMITS SHOWN MAY HAVE BEEN REDUCED BY PAID CLAIMS.

INSR LTR	TYPE OF INSURANCE	ADDL INSD	SUBR WVD	POLICY NUMBER	POLICY EFF (MM/DD/YYYY)	POLICY EXP (MM/DD/YYYY)	LIMITS
A	<input checked="" type="checkbox"/> COMMERCIAL GENERAL LIABILITY <input type="checkbox"/> CLAIMS-MADE <input checked="" type="checkbox"/> OCCUR <input checked="" type="checkbox"/> WA STOP GAP GEN'L AGGREGATE LIMIT APPLIES PER: <input type="checkbox"/> POLICY <input checked="" type="checkbox"/> PRO-JECT <input type="checkbox"/> LOC <input type="checkbox"/> OTHER:	Y		CLP 3706490	7/1/2021	7/1/2022	EACH OCCURRENCE \$ 1,000,000 DAMAGE TO RENTED PREMISES (Ea occurrence) \$ 300,000 MED EXP (Any one person) \$ 5,000 PERSONAL & ADV INJURY \$ 1,000,000 GENERAL AGGREGATE \$ 2,000,000 PRODUCTS - COMP/OP AGG \$ 2,000,000 JOB SITE POLLUTION \$ 1,000,000
A	<b>AUTOMOBILE LIABILITY</b> <input checked="" type="checkbox"/> ANY AUTO <input type="checkbox"/> OWNED AUTOS ONLY <input type="checkbox"/> SCHEDULED AUTOS <input checked="" type="checkbox"/> HIRED AUTOS ONLY <input checked="" type="checkbox"/> NON-OWNED AUTOS ONLY			CAP 3706491	7/1/2021	7/1/2022	COMBINED SINGLE LIMIT (Ea accident) \$ 1,000,000 BODILY INJURY (Per person) \$ BODILY INJURY (Per accident) \$ PROPERTY DAMAGE (Per accident) \$ POLLUTION \$ 1,000,000
A	<input checked="" type="checkbox"/> UMBRELLA LIAB <input checked="" type="checkbox"/> OCCUR <input type="checkbox"/> EXCESS LIAB <input type="checkbox"/> CLAIMS-MADE <input type="checkbox"/> DED <input checked="" type="checkbox"/> RETENTION \$ 10,000			CUP 2821413	7/1/2021	7/1/2022	EACH OCCURRENCE \$ 5,000,000 AGGREGATE \$ 5,000,000 \$
B	<b>WORKERS COMPENSATION AND EMPLOYERS' LIABILITY</b> ANY PROPRIETOR/PARTNER/EXECUTIVE OFFICER/MEMBER EXCLUDED? (Mandatory in NH) <input type="checkbox"/> Y/N If yes, describe under DESCRIPTION OF OPERATIONS below		N/A	782973	10/1/2021	10/1/2022	<input checked="" type="checkbox"/> PER STATUTE <input type="checkbox"/> OTH-ER OR E.L. EACH ACCIDENT \$ 1,000,000 E.L. DISEASE - EA EMPLOYEE \$ 1,000,000 E.L. DISEASE - POLICY LIMIT \$ 1,000,000
D C	POLLUTION LIABILITY INSTALLATION FLOATER LEASED/RENTED EQUIPMENT			ECPENV03043 QT6603834R447-TIA-21	8/8/2021 7/1/2021	7/1/2022 7/1/2022	EACH CLAIM   AGGREGAT ANY ONE JOBSITE/AGGR ANY ONE ITEM / AGGRE 2,000,000 250,000 250,000

**DESCRIPTION OF OPERATIONS / LOCATIONS / VEHICLES (ACORD 101, Additional Remarks Schedule, may be attached if more space is required)**

Certificate holder and all other entities are additional insureds when specified by written contract. Coverage is primary & non-contributory and includes waiver of subrogation when required by written contract. All subject to the terms, conditions and exclusions of the policies. Endorsements attached: GL-3086 (10/19), A2931 11/99, CA0444 10/13, WC000313.

Umbrella Excess Liability goes over General Liability, Auto and Employers Liability.

Project Name: # 2022-26 Salmonberry Drive Paving Project

**CERTIFICATE HOLDER**

Clackamas County  
 Procurement and Contracts  
 2051 Kaen Road  
 Oregon City OR 97045

**CANCELLATION**

SHOULD ANY OF THE ABOVE DESCRIBED POLICIES BE CANCELLED BEFORE THE EXPIRATION DATE THEREOF, NOTICE WILL BE DELIVERED IN ACCORDANCE WITH THE POLICY PROVISIONS.

AUTHORIZED REPRESENTATIVE

© 1988-2015 ACORD CORPORATION. All rights reserved.



**THIS ENDORSEMENT CHANGES THE POLICY. PLEASE READ IT CAREFULLY.**

**ADDITIONAL INSURED - SPECIFIC ENTITIES**

This endorsement modifies insurance provided under the following:

**BUSINESS AUTO COVERAGE FORM**

WHO IS AN INSURED is changed to include as an "insured" the person or organization named in this endorsement. However, the additional insured is an "insured" only for "bodily injury" or "property damage" arising out of work or operations performed by you or on your behalf for the additional insured and resulting from the ownership, maintenance or use of a "covered auto," by:

1. You, or
2. Any of your employees or agents; or
3. Anyone other than the additional insured or any employee or agent of the additional insured, while using with your permission a covered "auto" you own, hire or borrow.

**ADDITIONAL INSURED:**

ANY PERSON OR ORGANIZATION FOR WHOM THE NAMED INSURED HAS AGREED BY WRITTEN CONTRACT (INSURED CONTRACT) TO DESIGNATE AS AN ADDITIONAL INSURED SUBJECT TO ALL THE PROVISIONS AND LIMITATIONS OF THIS POLICY.

THIS INSURANCE WILL BE PRIMARY AND/OR NON-CONTRIBUTORY ONLY IF YOU HAVE SO AGREED IN A WRITTEN CONTRACT OR WRITTEN AGREEMENT EXECUTED PRIOR TO ANY LOSS.

POLICY NUMBER: CAP 3706491

S-2 Contractors, Inc.

COMMERCIAL AUTO  
CA 04 44 10 13

**THIS ENDORSEMENT CHANGES THE POLICY. PLEASE READ IT CAREFULLY.**

# **WAIVER OF TRANSFER OF RIGHTS OF RECOVERY AGAINST OTHERS TO US (WAIVER OF SUBROGATION)**

This endorsement modifies insurance provided under the following:

AUTO DEALERS COVERAGE FORM  
BUSINESS AUTO COVERAGE FORM  
MOTOR CARRIER COVERAGE FORM

With respect to coverage provided by this endorsement, the provisions of the Coverage Form apply unless modified by the endorsement.

This endorsement changes the policy effective on the inception date of the policy unless another date is indicated below.

<p><b>Named Insured:</b></p> <p><b>Endorsement Effective Date:</b></p>
--

## **SCHEDULE**

<p><b>Name(s) Of Person(s) Or Organization(s):</b></p> <p>"Any person or organization for whom the named insured is operating under written contract when such contract requires a waiver of subrogation."</p>
<p>Information required to complete this Schedule, if not shown above, will be shown in the Declarations.</p>

The **Transfer Of Rights Of Recovery Against Others To Us** condition does not apply to the person(s) or organization(s) shown in the Schedule, but only to the extent that subrogation is waived prior to the "accident" or the "loss" under a contract with that person or organization.

**THIS ENDORSEMENT CHANGES THE POLICY. PLEASE READ IT CAREFULLY.**

**TRANSPORTATION CONTRACTORS EXTENDED LIABILITY COVERAGE**

This endorsement modifies insurance provided under the following:

**COMMERCIAL GENERAL LIABILITY COVERAGE FORM**

It is agreed that the provisions listed below apply only upon the entry of an  in the box next to the caption of such provision.

- A.  Partnership and Joint Venture Extension
- B.  Contractors Automatic Additional Insured Coverage – Ongoing Operations
- C.  Automatic Waiver of Subrogation
- D.  Extended Notice of Cancellation, Nonrenewal
- E.  Unintentional Failure to Disclose Hazards
- F.  Broadened Mobile Equipment
- G.  Personal and Advertising Injury - Contractual Coverage
- H.  Nonemployment Discrimination
- I.  Liquor Liability
- J.  Broadened Conditions
- K.  Automatic Additional Insureds – Equipment Leases
- L.  Suits Against Dredges and Barges
- M.  Insured Contract Extension - Railroad Property and Construction Contracts
- N.  Construction Project General Aggregate Limits
- O.  Fellow Employee Coverage
- P.  Property Damage Liability - Elevators
- Q.  Care, Custody or Control
- R.  Electronic Data Liability Coverage
- S.  Consolidated Insurance Program Residual Liability Coverage
- T.  Automatic Additional Insureds – Managers or Lessors of Premises
- U.  Automatic Additional Insureds – State or Governmental Agency or Political Subdivisions – Permits or Authorizations
- V.  Contractors Automatic Additional Insured Coverage – Completed Operations
- W.  Additional Insured – Engineers, Architects or Surveyors

**A. PARTNERSHIP AND JOINT VENTURE EXTENSION**

The following provision is added to **SECTION II - WHO IS AN INSURED:**

The last full paragraph which reads as follows:

No person or organization is an insured with respect to the conduct of any current or past partnership, joint venture or limited liability company that is not shown as a Named Insured in the Declarations.

is deleted and replaced with the following:

With respect to the conduct of any past or present joint venture or partnership not shown as a Named Insured in the Declarations and of which you are or were a partner or member, you are an insured, but only with respect to liability arising out of "your work" on behalf of any partnership or joint venture not shown as a Named Insured in the Declarations, provided no other similar liability insurance is available to you for "your work" in connection with your interest in such partnership or joint venture.

## **B. CONTRACTORS AUTOMATIC ADDITIONAL INSURED COVERAGE – ONGOING OPERATIONS**

**SECTION II – WHO IS AN INSURED** is amended to include as an additional insured any person or organization who is required by written contract to be an additional insured on your policy, but only with respect to liability for "bodily injury", "property damage" or "personal and advertising injury" caused, in whole or in part, by:

1. Your acts or omissions; or
2. The acts or omissions of those acting on your behalf;

in the performance of your ongoing operations for the additional insured(s) at the project(s) designated in the written contract.

With respect to the insurance afforded to these additional insureds, the following additional exclusions apply:

This insurance does not apply to "bodily injury" or "property damage" occurring after:

1. All work, including materials, parts or equipment furnished in connection with such work, on the project (other than service, maintenance or repairs) to be performed by or on behalf of the additional insured(s) at the location of the covered operations has been completed; or
2. That portion of "your work" out of which the injury or damage arises has been put to its intended use by any person or organization other than another contractor or subcontractor engaged in performing operations for a principal as a part of the same project.

This insurance is excess of all other insurance available to the additional insured, whether primary, excess, contingent or on any other basis, unless the written contract requires this insurance to be primary. In that event, this insurance will be primary relative to insurance policy(s) which designate the additional insured as a Named Insured in the Declarations and we will not require contribution from such insurance if the written contract also requires that this insurance be non-contributory. But with respect to all other insurance under which the additional insured qualifies as an insured or additional insured, this insurance will be excess.

## **C. AUTOMATIC WAIVER OF SUBROGATION**

Item 8. of **SECTION IV - COMMERCIAL GENERAL LIABILITY CONDITIONS**, is deleted and replaced with the following:

8. **Transfer of Rights of Recovery Against Others to Us and Automatic Waiver of Subrogation.**
  - a. If the insured has rights to recover all or part of any payment we have made under this Coverage Form, those rights are transferred to us. The insured must do nothing after loss to impair those rights. At our request, the insured will bring "suit" or transfer those rights to us and help us enforce them.

- b. If required by a written contract executed prior to loss, we waive any right of recovery we may have against any person or organization because of payments we make for injury or damage arising out of "your work" for that person or organization.

#### **D. EXTENDED NOTICE OF CANCELLATION, NONRENEWAL**

Item **A.2.b.** of the **COMMON POLICY CONDITIONS**, is deleted and replaced with the following:

**A.2.b.** 60 days before the effective date of the cancellation if we cancel for any other reason.

Item **9.** of **SECTION IV - COMMERCIAL GENERAL LIABILITY CONDITIONS**, is deleted and replaced with the following:

#### **9. WHEN WE DO NOT RENEW**

- a. If we choose to nonrenew this policy, we will mail or deliver to the first Named Insured shown in the Declarations written notice of the nonrenewal not less than 60 days before the expiration date.
- b. If we do not give notice of our intent to nonrenew as prescribed in **a.** above, it is agreed that you may extend the period of this policy for a maximum additional sixty (60) days from its scheduled expiration date. Where not otherwise prohibited by law, the existing terms, conditions and rates will remain in effect during that extension period. It is further agreed that so long as it is not otherwise prohibited by law, this one time sixty day extension is the sole remedy and liquidated damages available to the insured as a result of our failure to give the notice as prescribed in **9. a.** above.

#### **E. UNINTENTIONAL FAILURE TO DISCLOSE HAZARDS**

Although we relied on your representations as to existing and past hazards, if unintentionally you should fail to disclose all such hazards at the inception date of your policy, we will not deny coverage under this Coverage Form because of such failure.

#### **F. BROADENED MOBILE EQUIPMENT**

Item **12.b.** of **SECTION V - DEFINITIONS**, is deleted and replaced with the following:

**12.b.** Vehicles maintained for use solely on or next to premises, sites or locations you own, rent or occupy.

#### **G. PERSONAL AND ADVERTISING INJURY - CONTRACTUAL COVERAGE**

**Exclusion 2.e.** of **SECTION I, COVERAGE B** is deleted.

#### **H. NONEMPLOYMENT DISCRIMINATION**

Unless "personal and advertising injury" is excluded from this policy:

Item **14.** of **SECTION V - DEFINITIONS**, is amended to include:

"Personal and advertising injury" also means embarrassment or humiliation, mental or emotional distress, physical illness, physical impairment, loss of earning capacity or monetary loss, which is caused by "discrimination."

**SECTION V - DEFINITIONS**, is amended to include:

"Discrimination" means the unlawful treatment of individuals based on race, color, ethnic origin, age, gender or religion.

Item **2. Exclusions** of **SECTION I, COVERAGE B**, is amended to include:

"Personal and advertising injury" arising out of "discrimination" directly or indirectly related to the past employment, employment or prospective employment of any person or class of persons by any insured;

"Personal and advertising injury" arising out of "discrimination" by or at your, your agents or your "employees" direction or with your, your agents or your "employees" knowledge or consent;

"Personal and advertising injury" arising out of "discrimination" directly or indirectly related to the sale, rental, lease or sub-lease or prospective sale, rental, lease or sub-lease of any dwelling, permanent lodging or premises by or at the direction of any insured.

Fines, penalties, specific performance or injunctions levied or imposed by a governmental entity, or governmental code, law, or statute because of "discrimination."

## **I. LIQUOR LIABILITY**

**Exclusion 2.c.** of **SECTION I, COVERAGE A**, is deleted.

## **J. BROADENED CONDITIONS**

Items **2.a.** and **2.b.** of **SECTION IV - COMMERCIAL GENERAL LIABILITY CONDITIONS**, are deleted and replaced with the following:

### **2. Duties In The Event Of Occurrence, Offense, Claim Or Suit:**

- a.** You must see to it that we are notified of an "occurrence" or an offense which may result in a claim as soon as practicable after the "occurrence" has been reported to you, one of your officers or an "employee" designated to give notice to us. Notice should include:
  - (1)** How, when and where the "occurrence" or offense took place;
  - (2)** The names and addresses of any injured persons and witnesses; and
  - (3)** The nature and location of any injury or damage arising out of the "occurrence" or offense.
- b.** If a claim is made or "suit" is brought against any insured, you must:
  - (1)** Record the specifics of the claim or "suit" and the date received as soon as you, one of your officers, or an "employee" designated to record such information is notified of it; and
  - (2)** Notify us in writing as soon as practicable after you, one of your officers, your legal department or an "employee" you designate to give us such notice learns of the claims or "suit."

Item **2.e.** is added to **SECTION IV - COMMERCIAL GENERAL LIABILITY CONDITIONS**:

- 2.e.** If you report an "occurrence" to your workers compensation insurer which develops into a liability claim for which coverage is provided by the Coverage Form, failure to report such "occurrence" to us at the time of "occurrence" shall not be deemed in violation of paragraphs **2.a.**, **2.b.**, and **2.c.** However, you shall give written notice of this "occurrence" to us as soon as you are made aware of the fact that this "occurrence" may be a liability claim rather than a workers compensation claim.

## **K. AUTOMATIC ADDITIONAL INSUREDS - EQUIPMENT LEASES**

**SECTION II - WHO IS AN INSURED** is amended to include any person or organization with whom you agree in a written equipment lease or rental agreement to name as an additional insured with respect to liability for "bodily injury", "property damage" or "personal and advertising injury" caused, at least in part, by your maintenance, operation, or use by you of the equipment leased to you by such person or organization, subject to the following additional exclusions.

The insurance provided to the additional insured does not apply to:

1. "Bodily injury" or "property damage" occurring after you cease leasing the equipment.
2. "Bodily injury" or "property damage" arising out of the sole negligence of the additional insured.
3. "Property damage" to:
  - a. Property owned, used or occupied by or rented to the additional insured; or
  - b. Property in the care, custody or control of the additional insured or over which the additional insured is for any purpose exercising physical control.

This insurance is excess of all other insurance available to the additional insured, whether primary, excess, contingent or on any other basis, unless the written contract requires this insurance to be primary. In that event, this insurance will be primary relative to insurance policy(s) which designate the additional insured as a Named Insured in the Declarations and we will not require contribution from such insurance if the written contract also requires that this insurance be non-contributory. But with respect to all other insurance under which the additional insured qualifies as an insured or additional insured, this insurance will be excess.

## **L. SUITS AGAINST DREDGES AND BARGES**

We agree that any "suit" in rem against any dredge or barge owned, operated by or for you, and used in your operations, shall in all respects be treated in the same manner as though the "suit" were against you.

This coverage is excess over and above any specific insurance on any dredge or barge owned, operated by or for you, and used in your operations.

## **M. INSURED CONTRACT EXTENSION - RAILROAD PROPERTY AND CONSTRUCTION CONTRACTS**

Item 9. of **SECTION V - DEFINITIONS**, is deleted and replaced with the following.

9. "Insured Contract" means:
  - a. A contract for a lease of premises. However, that portion of the contract for a lease of premises that indemnifies any person or organization for damage by fire to premises while rented to you or temporarily occupied by you with permission of the owner is not an "insured contract";
  - b. A sidetrack agreement;
  - c. Any easement or license agreement;
  - d. An obligation, as required by ordinance, to indemnify a municipality, except in connection with work for a municipality;
  - e. An elevator maintenance agreement;

- f. That part of any other contract or agreement pertaining to your business (including an indemnification of a municipality in connection with work performed for a municipality) under which you assume the tort liability of another party to pay for "bodily injury" or "property damage" to a third person or organization. Tort liability means a liability that would be imposed by law in the absence of any contract or agreement.

Paragraph f. does not include that part of any contract or agreement:

- (1) That indemnifies an architect, engineer or surveyor for injury or damage arising out of:
- (a) Preparing, approving, or failing to prepare or approve, maps, shop drawings, opinions, reports, surveys, field orders, change orders or drawings and specifications; or
  - (b) Giving directions or instructions, or failing to give them, if that is the primary cause of the injury or damage; or
- (2) Under which the insured, if an architect, engineer or surveyor, assumes liability for an injury or damage arising out of the insured's rendering or failure to render professional services, including those listed in (1) above and supervisory, inspection, architectural or engineering activities.

## **N. CONSTRUCTION PROJECT GENERAL AGGREGATE LIMITS**

This modifies **SECTION III - LIMITS OF INSURANCE**.

- A.** For all sums which can be attributed only to ongoing operations at a single construction project for which the insured becomes legally obligated to pay as damages caused by an "occurrence" under **SECTION I - COVERAGE A**, and for all medical expenses caused by accidents under **SECTION I - COVERAGE C**:
1. A separate Construction Project General Aggregate Limit applies to each construction project, and that limit is equal to the amount of the General Aggregate Limit shown in the Declarations.
  2. The Construction Project General Aggregate Limit is the most we will pay for the sum of all damages under **COVERAGE A**, except damages because of "bodily injury" or "property damage" included in the "products-completed operations hazard," and for medical expenses under **COVERAGE C** regardless of the number of:
    - a. Insureds;
    - b. Claims made or "suits" brought; or
    - c. Persons or organizations making claims or bringing "suits."
  3. Any payments made under **COVERAGE A** for damages or under **COVERAGE C** for medical expenses shall reduce the Construction Project General Aggregate Limit for that construction project. Such payments shall not reduce the General Aggregate Limit shown in the Declarations nor shall they reduce any other Construction Project General Aggregate Limit for any other construction project.
  4. The limits shown in the Declarations for Each Occurrence, Fire Damage and Medical Expense continue to apply. However, instead of being subject to the General Aggregate Limit shown in the Declarations, such limits will be subject to the applicable Construction Project General Aggregate Limit.



- B.** For all sums which cannot be attributed only to ongoing operations at a single construction project for which the insured becomes legally obligated to pay as damages caused by an "occurrence" under **SECTION I - COVERAGE A**, and for all medical expenses caused by accidents under **SECTION I - COVERAGE C**:
1. Any payments made under **COVERAGE A** for damages or under **COVERAGE C** for medical expenses shall reduce the amount available under the General Aggregate Limit or the Products-Completed Operations Aggregate Limit, whichever is applicable; and
  2. Such payments shall not reduce any Construction Project General Aggregate Limit.
- C.** Payments for damages because of "bodily injury" or "property damage" included in the "products-completed operations hazard" will reduce the Products-Completed Operations Aggregate Limit, and not reduce the General Aggregate Limit nor the Construction Project General Aggregate Limit.
- D.** If a construction project has been abandoned, delayed, or abandoned and then restarted, or if the authorized contracting parties deviate from plans, blueprints, designs, specifications or timetables, the project will still be deemed to be the same construction project.
- E.** The provisions of **SECTION III - LIMITS OF INSURANCE** not otherwise modified by this endorsement shall continue to be applicable.

**O. FELLOW EMPLOYEE COVERAGE**

**Exclusion 2.e. Employers Liability** of **SECTION I, COVERAGE A**, is deleted and replaced with the following:

**2.e.** "Bodily injury" to

(1) An "employee" of the insured arising out of and in the course of:

(a) Employment by the insured; or

(b) Performing duties related to the conduct of the insured's business; or

(2) The spouse, child, parent, brother or sister of that "employee" as a consequence of paragraph (1) above.

This exclusion applies:

(1) Whether the insured may be liable as an employer or in any other capacity; and

(2) To any obligation to share damages with or repay someone else who must pay damages because of the injury.

This exclusion does not apply to:

(1) Liability assumed by the insured under an "insured contract"; or

(2) Liability arising from any action or omission of a co-"employee" while that co-"employee" is either in the course of his or her employment or performing duties related to the conduct of your business.

Item 2.a. (1)(a) of **SECTION II - WHO IS AN INSURED**, is deleted and replaced with the following:

**2.a. (1)(a)** To you, to your partners or members (if you are a partnership or joint venture) or to your members (if you are a limited liability company), or to your "volunteer workers" while performing duties related to the conduct of your business.

#### **P. PROPERTY DAMAGE LIABILITY - ELEVATORS**

"Property damage" liability is changed as follows:

1. **Exclusions 2.j.(3) and 2.j.(4) of SECTION I, COVERAGE A**, do not apply to the use of elevators.
2. The insurance afforded by reason of this provision is excess over any valid and collectible property insurance (including any deductible portion thereof) available to the insured whether primary, excess, contingent or on any other basis, and the **OTHER INSURANCE** condition is changed accordingly.

#### **Q. CARE, CUSTODY OR CONTROL**

**Exclusion 2.j.4 of SECTION I, COVERAGE A**. is deleted and replaced with the following:

- 2.j.4** Personal property in the care, custody or control of the insured. However, for personal property in the care, custody or control of you or your "employees," this exclusion applies only to that portion of any loss in excess of \$25,000 per occurrence, subject to the following terms and conditions;
- (a) The most that we will pay under this provision as an annual aggregate is \$100,000, regardless of the number of occurrences.
  - (b) This provision does not apply to "employee" owned property or any property that is missing where there is not physical evidence to show what happened to the property.
  - (c) The aggregate limit for this coverage provision is part of the General Aggregate Limit and **SECTION III - LIMITS OF INSURANCE** is changed accordingly.
  - (d) In the event of damage to or destruction of property covered by this exception, you shall, if requested by us, replace the property or furnish the labor and materials necessary for repairs thereto, at actual cost to you, exclusive of prospective profit or overhead charges of any nature.
  - (e) \$2,500 shall be deducted from the total amount of all sums you became obligated to pay as damages on account of damage to or destruction of all property of each person or organization, including the loss of use of that property, as a result of each "occurrence." Our limit of liability under the endorsement as being applicable to each "occurrence" shall be reduced by the amount of the deductible indicated above; however, our aggregate limit of liability under this provision shall not be reduced by the amount of such deductible. The conditions of the policy, including those with respect to duties in the event of "occurrence," claims or "suit" apply irrespective of the application of the deductible amount. We may pay any part or all of the deductible amount to effect settlement of any claim or "suit" and, upon notification of the action taken, you shall promptly reimburse us for such part of the deductible amount as has been paid by us.

#### **R. ELECTRONIC DATA LIABILITY COVERAGE**

**A.** Exclusion **2.p.** of **COVERAGE A – BODILY INJURY AND PROPERTY DAMAGE LIABILITY** in **SECTION I – COVERAGES** is replaced by the following:

## 2. Exclusions

This insurance does not apply to:

### p. Access Or Disclosure Of Confidential Or Personal Information And Data-Related Liability

Damages arising out of:

- (1) Any access to or disclosure of any person's or organization's confidential or personal information, including patents, trade secrets, processing methods, customer lists, financial information, credit card information, health information or any other type of nonpublic information; or
- (2) The loss of, loss of use of, damage to, corruption of, inability to access, or inability to manipulate "electronic data" that does not result from physical injury to tangible property

This exclusion applies even if damages are claimed for notification costs, credit monitoring expenses, forensic expenses, public relations expenses or any other loss, cost or expense incurred by you or others arising out of that which is described in Paragraph (1) or (2) above.

However, unless Paragraph (1) above applies, this exclusion does not apply to damages because of "bodily injury".

## B. The following is added to Paragraph 2. EXCLUSIONS of SECTION I – COVERAGE B – PERSONAL AND ADVERTISING INJURY LIABILITY:

### 2. Exclusions

This insurance does not apply to:

#### Access Or Disclosure Of Confidential Or Personal Information

"Personal and advertising injury" arising out of any access to or disclosure of any person's or organization's confidential or personal information, including patents, trade secrets, processing methods, customer lists, financial information, credit card information, health information or any other type of nonpublic information.

This exclusion applies even if damages are claimed for notification costs, credit monitoring expenses, forensic expenses, public relations expenses or any other loss, cost or expense incurred by you or others arising out of any access to or disclosure of any person's or organization's confidential or personal information.

## C. The following definition is added to Section V – DEFINITIONS:

"Electronic data" means information, facts or programs stored as or on, created or used on, or transmitted to or from computer software (including systems and applications software), hard or floppy disks, CD-ROMS, tapes, drives, cells, data processing devices or any other media which are used with electronically controlled equipment.

## D. For the purposes of this coverage, the definition of "property damage" in SECTION V – DEFINITIONS is replaced by the following:

"Property damage" means:

- a. Physical injury to tangible property, including all resulting loss of use of that property. All such loss of use shall be deemed to occur at the time of the physical injury that caused it;

- b. Loss of use of tangible property that is not physically injured. All such loss of use shall be deemed to occur at the time of the "occurrence" that caused it; or
- c. Loss of, loss of use of, damage to, corruption of, inability to access, or inability to properly manipulate "electronic data", resulting from physical injury to tangible property. All such loss of "electronic data" shall be deemed to occur at the time of the "occurrence" that caused it.

For the purposes of this insurance, "electronic data" is not tangible property.

#### **S. CONSOLIDATED INSURANCE PROGRAM RESIDUAL LIABILITY COVERAGE**

With respect to "bodily injury", "property damage", or "personal and advertising injury" arising out of your ongoing operations; or operations included within the "products-completed operations hazard", the policy to which this coverage is attached shall apply as excess insurance over coverage available to "you" under a Consolidated Insurance Program (such as an Owner Controlled Insurance Program or Contractors Controlled Insurance Program).

Coverage afforded by this endorsement does not apply to any Consolidated Insurance Program involving a "residential project" or any deductible or insured retention, specified in the Consolidated Insurance Program.

The following is added to **Section V – Definitions**

"Residential project" means any project where 30% or more of the total square foot area of the structures on the project is used or is intended to be used for human residency. This includes but is not limited to single or multifamily housing, apartments, condominiums, townhouses, co-operatives or planned unit developments and appurtenant structures (including pools, hot tubs, detached garages, guest houses or any similar structures). A "residential project" does not include military owned housing, college/university owned housing or dormitories, long term care facilities, hotels, motels, hospitals or prisons.

All other terms, provisions, exclusions and limitations of this policy apply.

#### **T. AUTOMATIC ADDITIONAL INSURED - MANAGERS OR LESSORS OR PREMISES**

##### **SECTION II – WHO IS AN INSURED is amended to include:**

Any person or organization with whom you agree in a written contract or written agreement to name as an additional insured but only with respect to liability arising out of the ownership, maintenance or use of that part of the premises, designated in the written contract or written agreement, that is leased to you and subject to the following additional exclusions:

This insurance does not apply to:

1. Any "occurrence" which takes place after you cease to be a tenant in that premises.
2. Structural alterations, new construction or demolition operations performed by or on behalf of the additional insured listed in the written contract or written agreement.

This insurance is excess of all other insurance available to the additional insured, whether primary, excess, contingent or on any other basis, unless the written contract requires this insurance to be primary. In that event, this insurance will be primary relative to insurance policy(s) which designate the additional insured as a Named Insured in the Declarations and we will not require contribution from such insurance if the written contract also requires that this insurance be non-contributory. But with respect to all other insurance under which the additional insured qualifies as an insured or additional insured, this insurance will be excess.

#### **U. AUTOMATIC ADDITIONAL INSURED – STATE OR GOVERNMENTAL AGENCY OR POLITICAL SUBDIVISIONS – PERMITS OR AUTHORIZATIONS**

**SECTION II – WHO IS AN INSURED** is amended to include any state or governmental agency or subdivision or political subdivision with whom you are required by written contract, ordinance, law or building code to name as an additional insured subject to the following provisions:

This insurance applies only with respect to operations performed by you or on your behalf for which the state or governmental agency or subdivision or political subdivision has issued a permit or authorization.

This insurance does not apply to:

1. "Bodily injury", "property damage" or "personal and advertising injury" arising out of operations performed for the federal government, state or municipality; or
2. "Bodily injury" or "property damage" included within the "products-completed operations hazard".

This insurance is excess of all other insurance available to the additional insured, whether primary, excess, contingent or on any other basis, unless the written contract requires this insurance to be primary. In that event, this insurance will be primary relative to insurance policy(s) which designate the additional insured as a Named Insured in the Declarations and we will not require contribution from such insurance if the written contract also requires that this insurance be non-contributory. But with respect to all other insurance under which the additional insured qualifies as an insured or additional insured, this insurance will be excess.

#### **V. CONTRACTORS AUTOMATIC ADDITIONAL INSURED COVERAGE – COMPLETED OPERATIONS**

**SECTION II – WHO IS AN INSURED** is amended to include as an additional insured any person or organization who is required by written contract to be an additional insured on your policy for completed operations, but only with respect to liability for "bodily injury" or "property damage" caused, in whole or in part, by "your work" at the project designated in the contract, performed for that additional insured and included in the "products-completed operations hazard".

This insurance is excess of all other insurance available to the additional insured, whether primary, excess, contingent or on any other basis, unless the written contract requires this insurance to be primary. In that event, this insurance will be primary relative to insurance policy(s) which designate the additional insured as a Named Insured in the Declarations and we will not require contribution from such insurance if the written contract also requires that this insurance be non-contributory. But with respect to all other insurance under which the additional insured qualifies as an insured or additional insured, this insurance will be excess.

#### **W. ADDITIONAL INSURED – ENGINEERS, ARCHITECTS OR SURVEYORS**

**SECTION II – WHO IS AN INSURED** is amended to include as an additional insured any architect, engineer or surveyor who is required by written contract to be an additional insured on your policy, but only with respect to liability for "bodily injury", "property damage" or "personal and advertising injury" caused, in whole or in part, by:

1. Your acts or omissions; or
2. The acts or omissions of those acting on your behalf;

in the performance of your ongoing operations performed by you or on your behalf.

This includes such architect, engineer or surveyor, who may not be engaged by you, but is contractually required to be added as an additional insured to your policy.

With respect to the insurance afforded to these additional insureds, the following additional exclusion applies:

This insurance does not apply to "bodily injury", "property damage" or "personal and advertising injury" arising out of the rendering of or the failure to render any professional services, including:

1. The preparing, approving, or failing to prepare or approve maps, drawings, opinions, reports, surveys, change orders, designs or specifications; or
2. Supervisory, inspection or engineering services.

This insurance is excess of all other insurance available to the additional insured, whether primary, excess, contingent or on any other basis, unless the written contract requires this insurance to be primary. In that event, this insurance will be primary relative to insurance policy(s) which designate the additional insured as a Named Insured in the Declarations and we will not require contribution from such insurance if the written contract also requires that this insurance be non-contributory. But with respect to all other insurance under which the additional insured qualifies as an insured or additional insured, this insurance will be excess.

**Carrier no:** 20001

**Endorsement no:** WC000313  
(Ed. 430B)

**SAIF policy:** 782973 S-2 Contractors Inc

## **Waiver of Our Right to Recover from Others Endorsement**

We have the right to recover our payments from anyone liable for an injury covered by this policy. We will not enforce our right against the person or organization named in the Schedule.

This agreement shall not operate directly or indirectly to benefit anyone not named in the Schedule.

### **Schedule**

Description: ALL OPERATIONS

Contractor name: Persons and/or organizations with whom the insured-employer is required by written contract to waive subrogation rights.

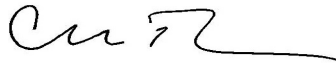
This endorsement does not alter the rights of an injured worker to pursue recovery from another party or SAIF to receive a statutory share of recoveries by an injured worker, even from the party listed in the schedule.

The premium charge for this endorsement is based on one (1) percent of your manual premium.

**Effective date:** October 01, 2021

This endorsement changes the policy to which it is attached and is effective on the date issued unless otherwise stated.

Countersigned September 28, 2021 at Salem, Oregon



WC000313  
(Ed. 430B)

Chip Terhune  
President and Chief Executive Officer