

ALTERNATIVE HIGH VOLUME DRIVEWAY WITH CURBS

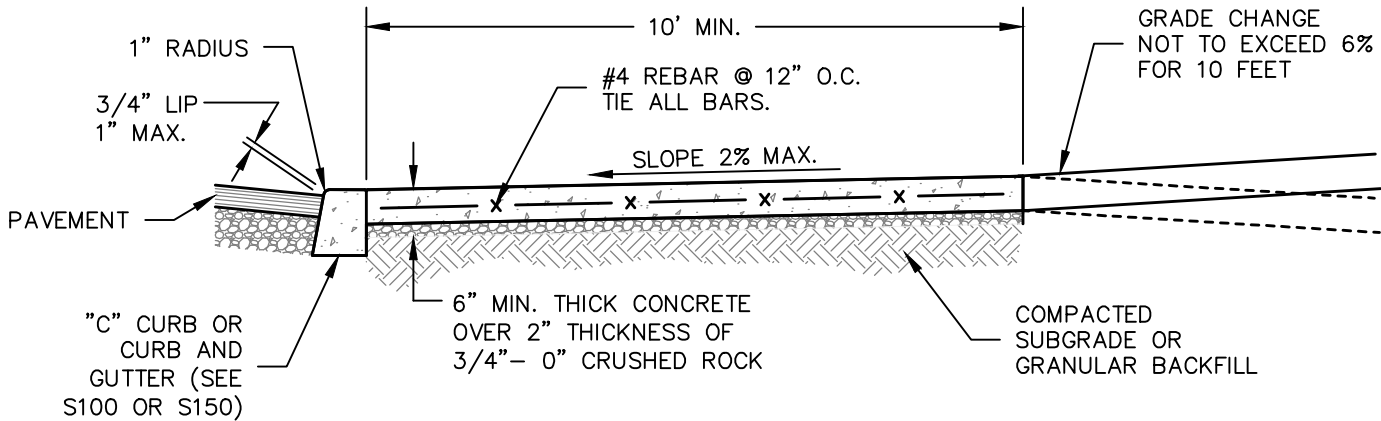
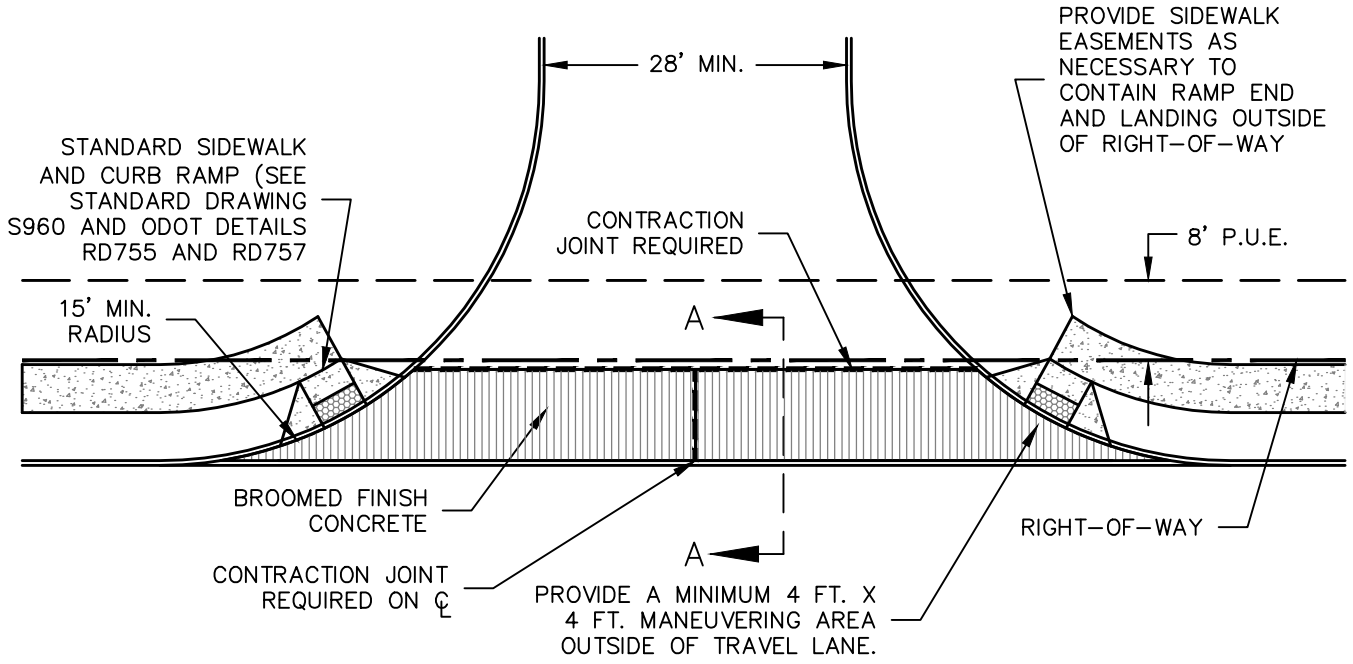

SECTION A-A

NOTES

1. THE USE OF THIS DETAIL MUST BE APPROVED BY THE COUNTY AND SHOULD ONLY BE USED AT HIGH VOLUME DRIVEWAYS.
2. LOCATION AND DIMENSIONS TO BE APPROVED BY THE COUNTY ON A SITE SPECIFIC BASIS.
3. SPECIFICATIONS FOR CONCRETE AND MISCELLANEOUS MATERIALS USED IN CONSTRUCTION SHALL CONFORM TO CURRENT ODOT/APWA STANDARD SPECIFICATIONS. CONCRETE SHALL HAVE A MINIMUM COMPRESSIVE STRENGTH OF 3300 P.S.I. IN 28 DAYS.
4. CLACKAMAS COUNTY DEPARTMENT OF TRANSPORTATION AND DEVELOPMENT TO BE NOTIFIED FOR INSPECTION PRIOR TO CONCRETE PLACEMENT AND FOR FINAL INSPECTION.
5. DAMAGE TO EXISTING CURBS AND PAVEMENT CAUSED AS A RESULT OF DRIVEWAY APPROACH INSTALLATION SHALL BE REPLACED OR REPAIRED TO THE SATISFACTION OF THE COUNTY.
6. EXPOSED AGGREGATE FINISH IS NOT ALLOWED.

REVISION	DATE	BY
REVISION	11/19	RM

DEPARTMENT OF TRANSPORTATION
AND DEVELOPMENT

150 BEAVERCREEK ROAD
OREGON CITY, OR 97045



APPROVAL DATE: 6/1/2020

SCALE: N.T.S.

**ALTERNATIVE HIGH VOLUME
DRIVEWAY WITH CURBS**

STANDARD
DRAWING

D675