

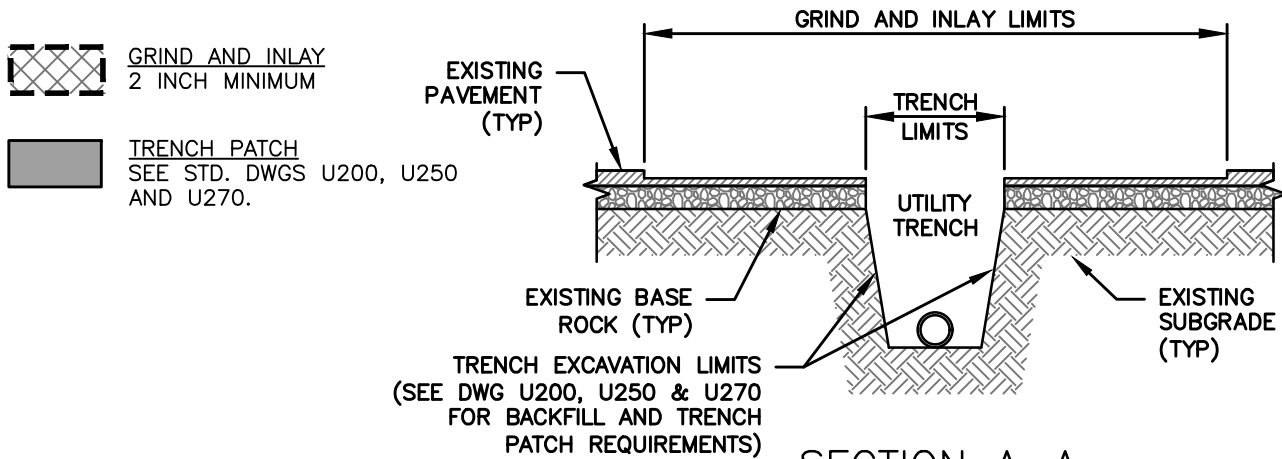

LEGEND:



NOTES:

1. ALL PATCH JOINTS SHALL BE CLEANED (SWEEP/BLOWN OUT) AND TACKED BEFORE PAVING.
2. ALL CUTS ARE TO BE PARALLEL AND PERPENDICULAR TO DIRECTION OF TRAFFIC.
3. GRIND AREA WILL BE CLEANED (SWEEP/BLOWN OUT) AND TACKED WITH HOT ASPHALT TACK COAT BEFORE INLAY IS COMPLETED.
4. AFTER PAVING HOT LIQUID ASPHALT WILL BE USED TO SAND SEAL ALL SEAMS.
5. SEE STD. DWG U290 TO ADDRESS MULTIPLE AND PROPOSED TRENCHES WITHIN 5 FEET OF EXISTING TRENCH REPAIRS.
6. THE ROAD RIGHT-OF-WAY WILL BE LEFT IN AS GOOD AS OR BETTER CONDITION THAN WHEN THE PROJECT BEGAN.
7. IF THE OUTSIDE SAW CUT IS LESS THAN THREE (3) FEET FROM THE E/PT OR CURB, THE EXISTING OUTSIDE ASPHALT TO THE E/P OR CURB MUST BE REMOVED AND REPLACED AS PART OF THE GRIND & INLAY LIMITS.
8. TRENCH LIMITS LESS THAN ONE FOOT FROM CENTERLINE OR LANE LINE SHALL EXTEND GRIND & INLAY LIMITS.
9. GRIND AND INLAY ADJACENT TO CURB RAMPS MAY REQUIRE ADA IMPROVEMENTS.
10. THE COUNTY MAY INCREASE OR DECREASE THESE REQUIREMENTS BASED ON LOCAL CONDITIONS.
11. COMPLY WITH SMOOTHNESS REQUIREMENTS OF OREGON STANDARD SPECIFICATIONS FOR CONSTRUCTION SECTION 00744.70

REVISION	DATE	BY	DEPARTMENT OF TRANSPORTATION AND DEVELOPMENT 150 BEAVERCREEK ROAD OREGON CITY, OR 97045		APPROVAL DATE: 6/1/2020	SCALE: N.T.S.	STANDARD DRAWING
REVISED	05/18	RN			PAVEMENT CUT STANDARD ARTERIAL/COLLECTOR ROADS	U275	
REVISED	09/18	RM					
REVISED	12/19	AAR					