



Elizabeth Comfort
Finance Director

Department of Finance

Public Services Building
2051 Kaen Road, Suite 490 | Oregon City, OR 97045

July 25, 2024

BCC Agenda Date/Item: _____

Board of County Commissioners
Clackamas County

Approval of a Contract with Becmen, LLC for the Lake Road Health Center Remodel Project. Total contract value is \$288,000 through November 30, 2024. Funding is through charges and fees. No County General Funds are involved.

Previous Board Action/Review	Briefed at Issues July 23, 2024		
Performance Clackamas	Build (maintain) a strong infrastructure. Ensure a safe, healthy and secure communities.		
Counsel Review	Yes	Procurement Review	Yes
Contact Person	Loren Frigault	Contact Phone	971.401.1104

EXECUTIVE SUMMARY: The Lake Road Health Center building, formerly the Pamplin Building, was acquired by Clackamas County in the fall of 2023. In order to meet the occupancy expectations of the new owner (Health, Housing, and Human Services), it is currently undergoing a significant renovation. A substantial component of this renovation is redefining the interior space for offices and communal rooms. In order to achieve this goal, it will require building new, sound-proofed walls to establish the new spaces.

Once the walls have been built, Health, Housing, and Human Services will have 24 new spaces at their disposal in the form of offices, conference rooms, and/or group and wellness rooms. In addition to this, secure doorways and a bathroom will be constructed. Lastly, a larger footprint will be afforded Genoa Pharmacy, allowing them to better assist the public.

This bid was advertised in accordance with ORS and LCRB Rules on April 23, 2024, and closed on May 23, 2024. Four general contracting companies submitted proposals, and after review, Becmen, LLC was determined to be lowest, responsive bidder and recommended for the award of this contract.

RECOMMENDATION: Given the scope and urgent timeline of the project completion, it is in the best interest of the County to hire a Contractor versus keep the work in-house. Facilities Management recommends that the framing, insulation, and drywall portion of the Lake Road Health Center Remodel be subcontracted out to Becmen, LLC.

Respectfully submitted,

Elizabeth Comfort

Elizabeth Comfort
Director Finance

For Filing Use Only



CLACKAMAS COUNTY
PUBLIC IMPROVEMENT CONTRACT
Contract #9690

This Public Improvement Contract (the “Contract”), is made by and between the Clackamas County, a political subdivision of the State of Oregon (“Owner”), and **Becmen LLC** (the “Contractor”), both collectively the “Parties”. This Contract shall become effective on the date this Contract has been signed by all the Parties and shall expire upon completion the completion of all obligations under the terms of this Contract unless terminated earlier by the Parties.

All capitalized terms in this Contract shall have the meanings identified in the Clackamas County General Conditions for Public Improvement Contracts (10/13/2021) (“General Conditions”) referenced within the Instructions to Bidders.

Project Name: **BID# 2024-31 Metal Framing, Insulation, and Drywall for Lake Road Health Center**

1. Contract Price, Contract Documents and Work.

The Contractor hereby agrees to perform all Work described in, and reasonably inferred from, the Contract Documents. In consideration of the Contractor performing the Work in accordance with the terms of the Contract, the Owner agrees to pay the Contractor the sum of **Two Hundred Eighty Eight Thousand Dollars (\$288,000.00)** (the "Contract Price"). Payment will be made in accordance with the terms and conditions provided in the Contract Documents. The Contract Price is the amount contemplated by the Base Bid, as indicated in the accepted Bid.

The following documents are incorporated by reference in this Contract and made a part hereof:

- Notice of Contract Opportunity
- Supplemental Instructions to Bidders
- Bid Form
- Clackamas County General Conditions
- Prevailing Wage Rates
- Plans, Specifications and Drawings
- Instructions to Bidders
- Bid Bond
- Performance Bond and Payment Bond
- Supplemental General Conditions
- Payroll and Certified Statement Form

2. Representatives.

Contractor has named Joe Bec as its Authorized Representative to act on its behalf. Owner designates, or shall designate, its Authorized Representative as indicted below (check one):

Unless otherwise specified in the Contract Documents, the Owner designates Loren Frigault as its Authorized Representative in the administration of this Contract. The above-named individual shall be the initial point of contact for matters related to Contract performance, payment, authorization, and to carry out the responsibilities of the Owner.

Name of Owner’s Authorized Representative shall be submitted by Owner in a separate writing.

3. Key Persons.

The Contractor’s personnel identified below shall be considered Key Persons and shall not be replaced during the project without the written permission of Owner, which shall not be unreasonably withheld. If the Contractor intends to substitute personnel, a request must be given to Owner at least 30 days prior to the intended time of substitution. When replacements have been approved by Owner, the Contractor shall provide a transition period of at least 10 working days during which the original and replacement personnel shall be

working on the project concurrently. Once a replacement for any of these staff members is authorized, further replacement shall not occur without the written permission of Owner. The Contractor's project staff shall consist of the following personnel:

Project Executive: Joe Bec shall be the Contractor's project executive, and will provide oversight and guidance throughout the project term.

4. Contract Dates.

The Contractor agrees to complete the Work in accordance with the following key dates:

COMMENCEMENT DATE: Upon Issuance of Notice to Proceed

SUBSTANTIAL COMPLETION DATE: November 15, 2024

FINAL COMPLETION DATE: November 30, 2024

Time is of the essence for this Contract. It is imperative that the Work in this Contract reach Substantial Completion and Final Completion by the above specified dates.

5. Reserved.

6. Insurance Certificates.

In accordance with Section G.3.5 of the General Conditions, Contractor shall furnish proof of the required insurance naming Clackamas County as an additional insured. Insurance certificates may be returned with the signed Contract or may be emailed to the County Contract Analyst.

7. Tax Compliance.

The Contractor shall comply with all federal, state and local laws, regulation, executive orders and ordinances applicable to this Contract. Contractor represents and warrants that it has complied, and will continue to comply throughout the duration of this Contract and any extensions, with all tax laws of this state or any political subdivision of this state, including but not limited to ORS 305.620 and ORS chapters 316, 317, and 318. Any violation of this section shall constitute a material breach of this Contract and shall entitle County to terminate this Contract, to pursue and recover any and all damages that arise from the breach and the termination of this Contract, and to pursue any or all of the remedies available under this Contract or applicable law.

8. Confidential Information.

Contractor acknowledges that it and its employees or agents may, in the course of performing their responsibilities under this Contract, be exposed to or acquire information that is confidential to Owner. Any and all information of any form obtained by Contractor or its employees or agents in the performance of this Contract shall be deemed confidential information of Owner ("Confidential Information"). Contractor agrees to hold Confidential Information in strict confidence, using at least the same degree of care that Contractor uses in maintaining the confidentiality of its own confidential information, and not to copy, reproduce, sell, assign, license, market, transfer or otherwise dispose of, give, or disclose Confidential Information to third parties or use Confidential Information for any purpose unless specifically authorized in writing under this Contract.

9. Counterparts.

This Contract may be executed in several counterparts, all of which when taken together shall constitute an agreement binding on all Parties, notwithstanding that all Parties are not signatories to the same counterpart. Each copy of the Contract so executed shall constitute an original.

10. Integration.

All provisions of state law required to be part of this Contract, whether listed in the General or Special Conditions or otherwise, are hereby integrated and adopted herein. Contractor acknowledges the obligations thereunder and that failure to comply with such terms is a material breach of this Contract.

The Contract Documents constitute the entire agreement between the parties. There are no other understandings, agreements or representations, oral or written, not specified herein regarding this Contract. Contractor, by the signature below of its authorized representative, hereby acknowledges that it has read this Contract, understands it, and agrees to be bound by its terms and conditions.

11. Compliance with Applicable Law. Contractor shall comply with all federal, state, county, and local laws, ordinances, and regulations applicable to the Work to be done under this Contract including, but not limited to, compliance with the prohibitions set forth in ORS 652.220, compliance of which is a material element of this Contract and failure to comply is a material breach that entitles County to exercise any rights and remedies available under this Contract including, but not limited to, termination for default.

12. Responsibility for Taxes. Contractor is solely responsible for payment of any federal, state, or local taxes required as a result of the Contract or the Work including, but not limited, to payment of the corporate activity tax imposed under enrolled HB 3427 (2019 Oregon regular legislative session). Contractor may not include its federal, state, or local tax obligations as part of the cost to perform the Work.

In witness whereof, Owner executes this Contract and the Contractor does execute the same as of the day and year first above written.

Contractor DATA:

Becmen LLC
12346 SE Spring Mountain Dr
Happy Valley, Oregon 97086

Contractor CCB # 216603 Expiration Date: 2/13/2026
Oregon Business Registry # 1350053-95 Entity Type: DLLC State of Formation: Oregon

Payment information will be reported to the IRS under the name and taxpayer ID# provided by the Contractor. Information must be provided prior to contract approval. Information not matching IRS records could subject Contractor to 28 percent backup withholding.

Becmen LLC

Clackamas County

Josif Bec 6/27/2024
Authorized Signature Date

Chair Date

— Josif Bec, Managing Member

_ Name / Title Printed

Recording Secretary

APPROVED AS TO FORM
lyg 06/27/2024

County Counsel Date



**CLACKAMAS COUNTY
PUBLIC IMPROVEMENT CONTRACT OPPORTUNITY**

Table of Contents

Section B-1.....Notice of Public Improvement Contract Opportunity

Section B-2.....Instructions to Bidders

Section B-3.....Supplemental Instructions to Bidders

Section B-4.....Bid Bond

Section B-5.....Bid Form

Section B-6.....Public Improvement Contract

Section B-7.....Supplemental General Conditions

Section B-8.....General Conditions

Section B-9.....Performance Bond

Section B-10.....Payment Bond

Section B-11.....Project Information, Plans, Specifications and Drawings



**CLACKAMAS COUNTY
NOTICE OF PUBLIC IMPROVEMENT CONTRACT OPPORTUNITY**

**INVITATION TO BID #2024-31
Metal Framing, Insulation, and Drywall For
Lake Road Health Center
April 23, 2024**

Clackamas County (“County”) through its Board of County Commissioners is accepting sealed bids for the **Metal Framing, Insulation, and Drywall For Lake Road Health Center** Project until **May 23, 2024, 2:00 PM**, Pacific Time, (“Bid Closing”) at the following location:

Bidding Documents can be downloaded from the state of Oregon procurement website (“OregonBuys”) at the following address: <https://oregonbuys.gov/bsv/view/login/login.xhtml>, Document No.S-C01010-00010180.

Prospective Bidders will need to sign in to download the information and that information will be accumulated for a Plan Holder's List. Prospective Bidders are responsible for obtaining any Addenda from Website listed above.

Submitting Proposals: Bid Locker

Proposals will only be accepted electronically thru a secure online bid submission service, **Bid Locker**. *Email submissions to Clackamas County email addresses will no longer be accepted.*

- A. Completed proposal documents must arrive electronically via Bid Locker located at <https://bidlocker.us/a/clackamascounty/BidLocker>.
- B. Bid Locker will electronically document the date and time of all submissions. Completed documents must arrive by the deadline indicated in Section 1 or as modified by Addendum. **LATE PROPOSALS WILL NOT BE ACCEPTED.**
- C. Proposers must register and create a profile for their business with Bid Locker in order to submit for this project. It is free to register for Bid Locker.
- D. Proposers with further questions concerning Bid Locker may review the Vendor’s Guide located at <https://www.clackamas.us/how-to-bid-on-county-projects>.

Contact Information

Procurement Process and Technical Questions: Tralee Whitley at TWhitley@clackamas.us

A **Non-Mandatory Pre-Bid Conference** will be conducted on **May 1, 2024 at 10:00 AM**. Bidders shall meet with County representatives site located at **6605 SE Lake Road, Milwaukie, Oregon** for that purpose. Attendance will be documented through a sign-in sheet prepared by the County representative.

Bids will be opened and publicly read aloud at the above Delivery address after the Bid Closing. Bid results will also be posted to the OregonBuys listing shortly after the opening.

Prevailing Wage

Prevailing Wage Rates requirements apply to this Project because the maximum compensation for all Owner-contracted Work is more than \$50,000. Contractor and all subcontractors shall comply with the provisions of ORS 279C.800 through 279C.870, relative to Prevailing Wage Rates. The Bureau of Labor and Industries (BOLI) wage rates and requirements set forth in the following BOLI booklet (and any listed amendments to that booklet), which are incorporated herein by reference, apply to the Work authorized under this Agreement:

PREVAILING WAGE RATES for Public Works Contracts in Oregon, January 5, 2024 and amended on April 5, 2024, which can be downloaded at the following web address:

http://www.oregon.gov/boli/WHD/PWR/Pages/pwr_state.aspx

The Work will take place in Clackamas County, Oregon.

Clackamas County encourages bids from Minority, Women, and Emerging Small Businesses.



CLACKAMAS COUNTY PUBLIC IMPROVEMENT CONTRACT

INSTRUCTIONS TO BIDDERS

Clackamas County Local Contract Review Board Rules (“LCRB Rules”) govern this procurement process. LCRB Rules may be found at: <http://www.clackamas.us/code/documents/appendixc.pdf>. The Instructions to Bidders is applicable to the procurement process for Clackamas County, or any component unit thereof identified on the Notice of Public Improvement Contract Opportunity, herein after referred to as the “Owner.”

Article 1. Scope of Work

The work contemplated under this contract with the Owner, includes all labor, materials, transportation, equipment and services necessary for, and reasonably incidental to, the completion of all construction work in connection with the project described in the Project Manual which includes, but is not necessarily limited to, the Notice of Public Improvement Contract Opportunity, Instructions to Bidders, Supplemental Instructions to Bidders, Bid Form, Bid Bond, Public Improvement Contract Form, Performance Bond, Payment Bond, Clackamas County General Conditions for Public Improvement Contracts (10/13/2021), Supplemental General Conditions, and Plans, Specifications and Drawings.

Article 2. Examination of Site and Conditions

Before making a Bid, the Bidder shall examine the site of the work and ascertain all the physical conditions in relation thereto. The Bidder shall also make a careful examination of the Project Manual including the plans, specifications, and drawings and other contract documents, and shall be fully informed as to the quality and quantity of materials and the sources of supply of the materials. Failure to take these steps will not release the successful Bidder from entering into the contract nor excuse the Bidder from performing the work in strict accordance with the terms of the contract at the

price established by the Bid.

The Owner will not be responsible for any loss or for any unanticipated costs, which may be suffered by the successful Bidder, as a result of such Bidder's failure to be fully informed in advance with regard to all conditions pertaining to the work and the character of the work required, including site conditions. No statement made by an elected official, officer, agent, or employee of the Owner in relation to the physical or other conditions pertaining to the site of the work will be binding on the Owner, unless covered by the Project Manual or an Addendum.

Article 3. Interpretation of Project Manual and Approval of Materials Equal to Those Provided in the Specifications

If any Bidder contemplating submitting a Bid for the proposed contract is in doubt as to the true meaning of any part of the plans, specifications or forms of contract documents, or detects discrepancies or omissions, such Bidder may submit to the Architect (read "Engineer" throughout in lieu of Architect as appropriate) a written request for an interpretation thereof at least ten (10) calendar days prior to the date set for the Bid Closing.

When a prospective Bidder seeks approval of a particular manufacturer's material, process or item of equal value, utility or merit other than that designated by the Architect in the Project Manual, the Bidder may submit to the Architect a written request for approval of such substitute at least ten (10) calendar days prior to the date set for the Bid Closing. The prospective Bidder submitting the request will be responsible for its prompt delivery.

Requests of approval for a substitution from that specified shall be accompanied by samples, records of performance, certified copies of tests by

impartial and recognized laboratories, and such other information as the Architect may request.

To establish a basis of quality, certain processes, types of machinery and equipment or kinds of materials may be specified in the Project Manual either by description of process or by designating a manufacturer by name and referring to a brand or product designation or by specifying a kind of material. Whenever a process is designated or a manufacturer's name, brand or item designation is given, or whenever a process or material covered by patent is designated or described, it shall be understood that the words "or approved equal" follow such name, designation or description, whether in fact they do so or not.

Any interpretation of the Project Manual or approval of manufacturer's material will be made only by an Addendum duly issued. All Addenda will be posted to the OregonBuys listing and will become a part of the Project Manual. The Owner will not be responsible for any other explanation or interpretation of the Project Manual nor for any other approval of a particular manufacturer's process or item for any Bidder.

When the Architect approves a substitution by Addendum, it is with the understanding that the Contractor guarantees the substituted article or material to be equal or better than the one specified.

Article 4. Security to Be Furnished by Each Bidder

Each Bid must be accompanied by either 1) a cashier's check or a certified check drawn on a bank authorized to do business in the State of Oregon, or 2) a Bid bond described hereinafter, executed in favor of the Owner, for an amount equal to ten percent (10%) of the total amount Bid as a guarantee that, if awarded the contract, the Bidder will execute the contract and provide a performance bond and payment bond as required. The successful Bidder's check or Bid bond will be retained until the Bidder has entered into a contract satisfactory to Owner and furnished a one hundred percent (100%) performance bond and one hundred percent (100%) payment bond. The Owner

reserves the right to hold the Bid security as described in Article 10 hereof. Should the successful Bidder fail to execute and deliver the contract as provided for in Article 12 hereof, including a satisfactory performance bond and payment bond within twenty (20) calendar days after the Bid has been accepted by the Owner, then the contract award made to such Bidder may be considered canceled and the Bid security may be forfeited as liquidated damages at the option of the Owner. The date of the acceptance of the Bid and the award of the contract as contemplated by the Project Manual shall mean the date of acceptance specified in the Notice of Intent to Award.

Article 5. Execution of Bid Bond

Should the Bidder elect to utilize a Bid bond as described in Article 4 in order to satisfy the Bid security requirements, such form must be completed in the following manner:

- A. Bid bonds must be executed on the County forms, which will be provided to all prospective Bidders by the Owner.
- B. The Bid bond shall be executed on behalf of a bonding company licensed to do business in the State of Oregon.
- C. In the case of a sole individual, the bond need only be executed as principal by the sole individual. In the case of a partnership, the bond must be executed by at least one of the partners. In the case of a corporation, the bond must be executed by stating the official name of the corporation under which is placed the signature of an officer authorized to sign on behalf of the corporation followed by such person's official capacity, such as president, etc. The corporation seal should then be affixed to the bond.
- D. The name of the surety must be stated in the execution over the signature of its duly authorized attorney-in-fact and accompanied by the seal of the surety corporation.

Article 6. Execution of the Bid Form

Each Bid shall be made in accordance with: (i) the sample Bid Form accompanying these instructions; (ii) the appropriate signatures for a sole individual, partnership, corporation or limited liability corporation shall be added as noted in Article 5C above; (iii) numbers pertaining to base Bids shall be stated both in writing and in figures; and (iv) the Bidder's address shall be typed or printed.

The Bid Form relates to Bids on a specific Project Manual. Only the amounts and information asked for on the Bid Form furnished will be considered as the Bid. Each Bidder shall Bid upon the work exactly as specified and provided in the Bid Form. The Bidder shall include in the Bid a sum to cover the cost of all items contemplated by the Contract. The Bidder shall Bid upon all alternates that may be indicated on the Bid Form. When Bidding on an alternate for which there is no charge, the Bidder shall write the words "No Charge" in the space provided on the Bid Form. If one or more alternates are shown on the Bid Form, the Bidder shall indicate whether each is "add" or "deduct."

Article 7. Prohibition of Alterations to Bid

Bids that are incomplete, or contain ambiguities or have differing conditions required by the Bidder, including requested changes or exceptions to the Public Improvement Contract form or other portions of the Project Manual, may be rejected in Owner's sole and absolute discretion.

Article 8. Submission of Bid

Each Bid shall be sealed in an envelope, properly addressed to the Owner, showing on the outside of the envelope the name of the Bidder and the name of the project. Bids will be received at the time and place stated in the Notice of Public Improvement Contract Opportunity.

Article 9. Bid Closing and Opening of Bids

All Bids must be received by the Owner at the place and time set for the Bid Closing. Any Bids received after the scheduled Bid Closing time for

receipt of Bids will be rejected.

At the time of opening and reading of Bids, each Bid received will be publicly opened and read aloud, irrespective of any irregularities or informalities in such Bids.

Generally, Bid results will be posted to the OregonBuys Website within a couple hours of the opening.

Article 10. Acceptance or Rejection of Bids by Owner

Unless all Bids are rejected, the Owner will award a contract based on the lowest responsive Bid from a responsible Bidder. If that Bidder does not execute the contract, it will be awarded to the next lowest responsible Bidder or Bidders in succession.

The Owner reserves the right to reject all Bids and to waive minor informalities. The procedures for contract awards shall be in compliance with the provisions of the LCRB Rules in effect at that time.

The Owner reserves the right to hold the Bid and Bid security of the three lowest Bidders for a period of thirty (30) calendar days from and after the time of Bid opening pending award of the contract. Following award of the contract the Bid security of the three lowest Bidders may be held twenty (20) calendar days pending execution of the contract. All other Bids will be rejected and Bid security will be returned.

In determining the lowest Bidder, the Owner reserves the right to take into consideration any or all authorized base Bids as well as alternates or combinations indicated in the Bid Form.

If no Bid has been accepted within thirty (30) calendar days after the opening of the Bids, each of the three lowest Bidders may withdraw the Bid submitted and request the return of the Bid security.

Article 11. Withdrawal of Bid

At any time prior to the Bid Closing, a Bidder may withdraw its Bid. This will not preclude the

submission of another Bid by such Bidder prior to the time set for the Bid Closing.

After the time set for the Bid Closing, no Bidder will be permitted to withdraw its Bid within the time frames specified in Article 10 for award and execution, except as provided for in that Article.

Article 12. Execution of Contract, Performance Bond and Payment Bond

The Owner will provide the successful Bidder with contract forms within seven (7) calendar days after the completion of the award protest period. The Bidder is required to execute the contract forms as provided, including a performance bond and a payment bond from a surety company licensed to do surety business in the State of Oregon, within seven (7) calendar days after receipt of the contract forms. The contract forms shall be delivered to the Owner in the number called for and to the location as instructed by the Owner.

Article 13. Recyclable Products

Contractors will use recyclable products to the maximum extent economically feasible in the performance of the Contract.

Article 14. Clarification or Protest of the Solicitation Document or Specifications

Any request for clarification or protest of the solicitation document or specifications must be submitted in the manner provided for in the applicable section of the LCRB Rules to the Procurement Representative referenced in the Notice of Public Improvement Contract Opportunity.

A protest of the Solicitation Document must be received within seven (7) business days of the issuance of the Bid or within three (3) business days of issuance of an addendum.

Requests for clarification may be submitted no less than five (5) business days prior to the Bid Closing Date.

Article 15. Protest of Intent to Award

Owner will name the apparent successful Bidder in a "Notice of Intent to Award" letter. Identification of the apparent successful Bidder is procedural only and creates no right in the named Bidder to the award of the contract. Competing Bidders will be notified by publication of the Notice of Intent to Award on the OregonBuys Website of the selection of the apparent successful Bidder(s) and Bidders shall be given seven (7) calendar days from the date on the "Notice of Intent to Award" letter to review the file at the Procurement Division office and file a written protest of award, pursuant to C-049-0450. Any award protest must be in writing and must be delivered by email, hand delivery, or mail to the Procurement Division Director at: Procurement Division, 2051 Kaen Road, Oregon City, OR 97045.

Article 16. Disclosure of First-Tier Subcontractors

Within two (2) working hours after the Bid Closing, all Bidders shall submit to the County a disclosure form identifying any first-tier subcontractors (those entities that would be contracting directly with the prime contractor) that will be furnishing labor and materials on the contract, if awarded, whose subcontract value would be equal to or greater than: (a) Five percent (5%) of the total contract price, but at least \$15,000; or (b) \$350,000, regardless of the percentage of the total contract price.

Disclosures may be submitted with the Bid or may be hand delivered to the Bid Closing address or emailed to the Contract Information Analyst listed on the Notice of Contract Opportunity.



**CLACKAMAS COUNTY
PUBLIC IMPROVEMENT CONTRACT**

SUPPLEMENTAL INSTRUCTIONS TO BIDDERS

**Project Name BID# 2024-31 Metal Framing, Insulation, and Drywall For
Lake Road Health Center**

The following modify the Clackamas County “Instructions to Bidders” for this Project. Where a portion of the Instructions to Bidders has been modified by these Supplemental Instructions to Bidders, the unaltered portions shall remain in effect.

- 1. A Non-Mandatory Pre-Bid Conference** will be conducted on **May 1, 2024 at 10:00 AM**. Bidders shall meet with County representatives site located at 6605 SE Lake Road, Milwaukie, Oregon for that purpose. Attendance will be documented through a sign-in sheet prepared by the County representative.
- 2. Electronic Submissions:** The County is requiring all bids for this project be electronically submitted. Complete Bids (including all attachments) will only be accepted electronically thru a secure online bid submission service, Bid Locker. Email submissions to Clackamas County email addresses will no longer be accepted.
<https://bidlocker.us/a/clackamascountry/BidLocker>.

Bids will be publicly read aloud via the computer application, Zoom. Bidders will be allowed to video conference or listen by phone to the bid results. The projects Zoom meeting can be accessed via the information below:

ZOOM LINKS

Join Zoom Meeting

<https://clackamascountry.zoom.us/j/87322823310>

Meeting ID: 873 2282 3310

One tap mobile

+16699006833,,87322823310# US (San Jose) 17193594580,,87322823310# US

Dial by your location

- +1 669 900 6833 US (San Jose)
- +1 719 359 4580 US
- +1 253 205 0468 US
- +1 253 215 8782 US (Tacoma)
- +1 346 248 7799 US (Houston)
- +1 408 638 0968 US (San Jose)
- +1 669 444 9171 US

- +1 312 626 6799 US (Chicago)
- +1 360 209 5623 US
- +1 386 347 5053 US
- +1 507 473 4847 US
- +1 564 217 2000 US
- +1 646 876 9923 US (New York)
- +1 646 931 3860 US
- +1 689 278 1000 US
- +1 301 715 8592 US (Washington DC)
- +1 305 224 1968 US
- +1 309 205 3325 US

Meeting ID: 873 2282 3310

Find your local number: <https://clackamascounty.zoom.us/j/87322823310>

**The Apparent Low bid results will be posted to the projects OregonBuys listing as soon as possible following the bid opening.

3. **Good Faith Effort:** Clackamas County encourages participation in contracts by Historically Underrepresented Businesses. “Historically Underrepresented Businesses” are State of Oregon-certified and self-identified minority, women and emerging small business as well as firms that are certified federally or by another state or entity with substantially similar requirements as the State of Oregon.

Bidders must perform Good Faith Effort (defined below) and submit **Form 1 and Form 2** for the Bidders Bid to be considered responsive. **Form 1 and Form 2** must be submitted within **two (2) hours** after the Closing Date and Time. Form 1 and Form 2 may be submitted to either the Contact Information Analyst listed on Notice of Contract Opportunity or via the <https://bidlocker.us/a/clackamascounty/BidLocker> listing.

“Good Faith Effort” is a requirement of a prime contractor to reach out to at least three Historically Underrepresented Business Subcontractors for each division of work that will be subcontracted out and to complete the required forms. If fewer than three Historically Underrepresented Business Subcontractors are reasonably available for a particular division of work, the Bidder must specifically note the reason for there being fewer than three contacts. The outreach should be performed with sufficient time to give the subcontractors at least 5 calendar days to respond to the opportunity. Form 3, which documents the actual amount of subcontractors on the project, must be submitted with the project final pay application. Compliance with the Good Faith Effort and submission of Forms 1, 2 and 3 is a contractual requirement for final payment.

The sufficiency of the documentation or the performance of Good Faith Effort shall be in the sole and absolute determination of Clackamas County. Only those Bidders that Clackamas County has determined have not sufficiently performed Good Faith Effort shall have protest rights of the determination for such Bidder. No Bidder shall have protest rights of the sufficiency of any other Bidder completing Good Faith Effort.

**CLACKAMAS COUNTY
GOOD FAITH EFFORT
SUBCONTRACTOR AND SELF-PERFORMED WORK LIST
(FORM 1)**

Prime Contractor Name:

Total Contract Amount:

Project Name: BID# 2024-31 Metal Framing, Insulation, and Drywall For
Lake Road Health Center

PRIME SELF-PERFORMING: Identify below ALL GFE Divisions of Work (DOW) to be self-performed. Good Faith Efforts are otherwise required.

DOW BIDDER WILL SELF-PERFORM (GFE not required)

ALL DIVISIONS WILL SELF PERFORM	

PRIME CONTRACTOR SHALL DISCLOSE AND LIST ALL SUBCONTRACTORS, including those Minority-owned, Woman-owned, and Emerging Small Businesses ("M/W/ESB") that you intend to use on the project. Delivery via bid locker <https://bidlocker.us/a/clackamascounty/BidLocker> within 2 hours of the BID/Quote Closing Date/Time.

LIST ALL SUBCONTRACTORS BELOW Use <u>correct legal name</u> of Subcontractor (No Assumed Business Names)	Division of Work (Painting, electrical, landscaping, etc.) List ALL DOW performed by Subcontractors	DOLLAR AMOUNT OF SUBCONTRACT	If Certified or self-reporting MBE/WBE/ESB Subcontractor Check box <input checked="" type="checkbox"/>		
			MBE	WBE	ESB
Name Address City/St/Zip Phone# OCCB#			<input type="checkbox"/>	<input type="checkbox"/>	<input type="checkbox"/>
Name Address City/St/Zip Phone# OCCB#			<input type="checkbox"/>	<input type="checkbox"/>	<input type="checkbox"/>
Name Address City/St/Zip Phone# OCCB#			<input type="checkbox"/>	<input type="checkbox"/>	<input type="checkbox"/>
Name Address City/St/Zip Phone# OCCB#			<input type="checkbox"/>	<input type="checkbox"/>	<input type="checkbox"/>

GFE SUBCONTRACTOR AND SELF-PERFORMED WORK LIST (FORM 1) cont'd

**CLACKAMAS COUNTY
GOOD FAITH EFFORT
M/W/ESB CONTACT / BIDS RECEIVED LOG
(FORM 2)**

Prime Contractor:

Project: BID# 2024-31 Metal Framing, Insulation, and Drywall For Lake Road Health Center

Prime Contractor must contact or endeavor to contact at least 3 M/W/ESB Subcontractors for each Division of Work. Prime Contractor shall record its contacts with M/W/ESB Subcontractors through use of this log (or equivalent) entering all required information. All columns shall be completed where applicable. Additional forms may be copied if needed.

NAME OF M/W/ESB SUBCONTRACTOR	Divisions of Work (Painting, electrical, landscaping, etc.)	Date Solicitation Letter / Fax Sent	PHONE CONTACT		BID ACTIVITY Check Yes or No			REJECTED BIDS (if bid received & not used)		Notes
			Date of Call	Person Receiving Call	Will Bid	Bid Received	Bid Used	Bid Amount	Reason Not Used (Price, Scope or Other. If Other, explain in Notes>>)	
					<input type="checkbox"/> Yes <input type="checkbox"/> No	<input type="checkbox"/> Yes <input type="checkbox"/> No	<input type="checkbox"/> Yes <input type="checkbox"/> No			
					<input type="checkbox"/> Yes <input type="checkbox"/> No	<input type="checkbox"/> Yes <input type="checkbox"/> No	<input type="checkbox"/> Yes <input type="checkbox"/> No			
					<input type="checkbox"/> Yes <input type="checkbox"/> No	<input type="checkbox"/> Yes <input type="checkbox"/> No	<input type="checkbox"/> Yes <input type="checkbox"/> No			
					<input type="checkbox"/> Yes <input type="checkbox"/> No	<input type="checkbox"/> Yes <input type="checkbox"/> No	<input type="checkbox"/> Yes <input type="checkbox"/> No			
					<input type="checkbox"/> Yes <input type="checkbox"/> No	<input type="checkbox"/> Yes <input type="checkbox"/> No	<input type="checkbox"/> Yes <input type="checkbox"/> No			
					<input type="checkbox"/> Yes <input type="checkbox"/> No	<input type="checkbox"/> Yes <input type="checkbox"/> No	<input type="checkbox"/> Yes <input type="checkbox"/> No			
					<input type="checkbox"/> Yes <input type="checkbox"/> No	<input type="checkbox"/> Yes <input type="checkbox"/> No	<input type="checkbox"/> Yes <input type="checkbox"/> No			

**CLACKAMAS COUNTY
GOOD FAITH EFFORT
PROJECT COMPLETION REPORT
(FORM 3)**

Prime Contractor Name:

Total Contract Amount:

Project Name: BID# 2024-31 Metal Framing, Insulation, and Drywall For
Lake Road Health Center

Complete this form and submit with your request for final payment upon the project completion. Please list all subcontractors used for the project. Use additional sheets as necessary.

<u>LIST ALL</u> SUBCONTRACTORS BELOW Use <u>correct legal name</u> of Subcontractor (No Assumed Business Names)	Division of Work (Painting, electrical, landscaping, etc.) List ALL DOW performed by Subcontractors	FINAL DOLLAR AMOUNT OF SUBCONTRACT	If Certified or self-reported MBE/WBE/ESB Subcontractor Check box <input checked="" type="checkbox"/>		
			MBE	WBE	ESB
Name Address City/St/Zip Phone# OCCB#			<input type="checkbox"/>	<input type="checkbox"/>	<input type="checkbox"/>
Name Address City/St/Zip Phone# OCCB#			<input type="checkbox"/>	<input type="checkbox"/>	<input type="checkbox"/>
Name Address City/St/Zip Phone# OCCB#			<input type="checkbox"/>	<input type="checkbox"/>	<input type="checkbox"/>
Name Address City/St/Zip Phone# OCCB#			<input type="checkbox"/>	<input type="checkbox"/>	<input type="checkbox"/>
Name Address City/St/Zip Phone# OCCB#			<input type="checkbox"/>	<input type="checkbox"/>	<input type="checkbox"/>
Name Address City/St/Zip Phone# OCCB#			<input type="checkbox"/>	<input type="checkbox"/>	<input type="checkbox"/>

BY SIGNING BELOW, I HEREBY CERTIFY THAT THE ABOVE LISTED FIRMS HAVE BEEN UTILIZED BY OUR COMPANY IN THE AMOUNTS REPRESENTED ABOVE AND THAT THE INFORMATION CONTAINED HEREIN IS COMPLETE AND ACCURATE. .

Authorized Signature of Contractor Representative

Date

Notice to Purchaser - In the event that this check is lost, misplaced or stolen, a sworn statement and 90-day waiting period will be required prior to replacement. This check should be negotiated within 90 days.

Cashier's Check - Customer Copy

No. 0924220398

Void After 90 Days

91-170/1221

Date 05/23/24 12:57:36 PM

MOUNT TALBERT

0001 0003024 0017

NAZ

00-53-3364B 06-2019

Pay



****\$32,000.00****

****Thirty Two Thousand and 00/100 Dollars****

To The
Order Of CLACKAMAS COUNTY
MEMO: BID 2024-31

Not-Negotiable
Customer Copy
Retain for your Records

Remitter (Purchased By): JOSIF BEC

457002931733

Bank of America, N.A.
PHOENIX, AZ

BANK OF AMERICA

Cashier's Check

No. 0924220398

Notice to Purchaser - In the event that this check is lost, misplaced or stolen, a sworn statement and 90-day waiting period will be required prior to replacement. This check should be negotiated within 90 days.

Void After 90 Days

91-170/1221

Date 05/23/24 12:57:36 PM

MOUNT TALBERT

0001 0003024 0017

NAZ

Pay



****\$32,000.00****

****Thirty Two Thousand and 00/100 Dollars****

To The
Order Of CLACKAMAS COUNTY
MEMO: BID 2024-31

Remitter (Purchased By): JOSIF BEC

Bank of America, N.A.
PHOENIX, AZ

AUTHORIZED SIGNATURE

00-53-3364B 06-2019

⑈0924220398⑈ ⑆122101706⑆ 457002931733⑈



CLACKAMAS COUNTY
PUBLIC IMPROVEMENT CONTRACT

BID FORM

PROJECT: BID# 2024-31 Metal Framing, Insulation, and Drywall for Lake Road Health Center
BID CLOSING: May 23, 2024, 2:00 PM, Pacific Time
BID OPENING: May 23, 2024, 2:05 PM, Pacific Time

FROM: BECKEN LLC
Bidder's Name (must be full legal name, not ABN/DBA)

TO: https://bidlocker.us/a/clackamascounty/BidLocker

1. Bidder is (check one of the following and insert information requested):

- a. An individual; or
- b. A partnership registered under the laws of the State of _____; or
- c. A corporation organized under the laws of the State of _____; or
- d. A limited liability corporation organized under the laws of the State of OREGON;

and authorized to do business in the State of Oregon hereby proposes to furnish all material and labor and perform all work hereinafter indicated for the above project in strict accordance with the Contract Documents for the Basic Bid as follows:

two hundred eighty eight thousand Dollars (\$ 288,000)

and the Undersigned agrees to be bound by the following documents:

- Notice of Public Improvement Contract Opportunity
 - Instructions to Bidders
 - Bid Bond
 - Public Improvement Contract Form
 - Clackamas County General Conditions
 - Prevailing Wage Rates
 - Plans, Specifications and Drawings
 - Supplemental Instructions to Bidders
 - Bid Form
 - Performance Bond and Payment Bond
 - Supplemental General Conditions
 - Payroll and Certified Statement Form
- ADDENDA numbered _____ through _____, inclusive (fill in blanks)

2. The Undersigned proposes to add to or deduct from the Base Bid indicated above the items of work relating to the following Alternate(s) as designated in the Specifications: N/A

3. The Undersigned proposes to add to or deduct from the Base Bid indicated above the items or work relating to the following Unit Price(s) as designated in the Specifications, for which any adjustments in the Contract amount will be made in accordance with Section D of the Clackamas County General Conditions: **provide attached bid schedule with bid.**

4. The work shall be completed within the time stipulated and specified in the contract documents.

5. Accompanying herewith is Bid Security which is equal to ten percent (10%) of the total amount of the Basic Bid, plus the total sum of all Alternatives (if any).

6. The Undersigned agrees, if awarded the Contract, to execute and deliver to Clackamas County, within twenty (20) calendar days after receiving the Contract forms, a Contract Form, and a satisfactory Performance Bond and Payment Bond each in an amount equal to one hundred percent (100%) of the Contract sum, using forms provided by the Owner. The surety requested to issue the Performance Bond and Payment Bond will be:

WESTERN SURETY COMPANY
(name of surety company - not insurance agency)

The Undersigned hereby authorizes said surety company to disclose any information to the Owner concerning the Undersigned's ability to supply a Performance Bond and Payment Bond each in the amount of the Contract.

7. The Undersigned further agrees that the Bid Security accompanying the Bid is left in escrow with Clackamas County; that the amount thereof is the measure of liquidated damages which the Owner will sustain by the failure of the Undersigned to execute and deliver the above-named Contract Form, Performance Bond and Payment Bond, each as published, and that if the Undersigned defaults in either executing the Contract Form or providing the Performance Bond and Payment Bond within twenty (20) calendar days after receiving the Contract forms, then the Bid Security shall become the property of the Owner at the Owner's option; but if the Bid is not accepted within thirty (30) calendar days of the time set for the opening of the Bids, or if the Undersigned executes and timely delivers said Contract Form, Performance Bond and Payment Bond, the Bid Security shall be returned.

8. The Undersigned certifies that: (i) This Bid has been arrived at independently and is being submitted without collusion with and without any agreement, understanding, or planned common course of action with any other vendor of materials, supplies, equipment or services described in the invitation to bid designed to limit independent bidding or competition; and (ii) the contents of the Bid have not been communicated by the Undersigned or its employees or agents to any person not an employee or agent of the Undersigned or its surety on any Bond furnished with the Bid and will not be communicated to such person prior to the official opening of the Bid.

9. The undersigned HAS, HAS NOT (check one) paid unemployment or income taxes in Oregon within the past 12 months and DOES, DOES NOT (check one) a business address in Oregon. The undersigned acknowledges that, if the selected bidder, that the undersigned will have to pay all applicable taxes and register to do business in the State of Oregon before executing the Contract Form.

10. The Undersigned agrees, if awarded a contract, to comply with the provisions of ORS 279C.800 through 279C.870 pertaining to the payment of the prevailing rates of wage.

11. Contractor's CCB registration number is 216603. As a condition to submitting a bid, a Contractor must be registered with the Oregon Construction Contractors Board in accordance with ORS 701.035 to 701.055, and disclose the registration number. Failure to register and disclose the number will make the bid unresponsive and it will be rejected, unless contrary to federal law.

12. The successful Bidder hereby certifies that all subcontractors who will perform construction work as described in ORS 701.005(2) were registered with the Construction Contractors Board in accordance with ORS 701.035 to 701.055 at the time the subcontractor(s) made a bid to work under the contract.

13. The successful Bidder hereby certifies that, in compliance with the Worker's Compensation Law of the State of Oregon, its Worker's Compensation Insurance provider is SAIF, Policy No. 100042351, and that Contractor shall submit Certificates of Insurance as required.

14. Contractor's Key Individuals for this project (supply information as applicable):
 Project Executive: JOE BEC, Cell Phone: 503-515-4287
 Project Manager: S, Cell Phone: S
 Job Superintendent: S, Cell Phone: S
 Project Engineer: _____, Cell Phone: _____

15. The Undersigned certifies that it has not discriminated against minority, women, or emerging small businesses in obtaining any subcontracts for this project.

16. The Undersigned certifies that it has a drug testing program in accordance with ORS 279C.505.

REMINDER: Bidder must submit the below First-Tier Subcontractor Disclosure Form.

By signature below, Contractor agrees to be bound by this Bid.

NAME OF FIRM BECMEN LLC
 ADDRESS 12346 SE Spring Mountain Dr.
Happy Valley OR 97086
 TELEPHONE NO 503-515-4287
 EMAIL Becmen LLC @ gmail.com
 SIGNATURE 1) _____
 Sole Individual
 or 2) _____
 Partner
 or 3) Joe Bec
 Authorized Officer or Employee of Corporation

***** END OF BID *****

Lake Road Health Center

Bidder will complete the Work in accordance with the Contract Documents for the following price(s):

Lake Road Health Center Remodel

BID#

No.	Item	Quantity	Unit of Measure	Unit Price or Lump Sum Price Figures	Total Amount
1	Mobilization	1	Lump Sum	20000	\$ 20000 -
2	Install Steel Wall Framing	1	Lump Sum	125000	\$ 125000 -
3	Install noise dampening insulation & caulking	1	Lump Sum	58000	\$ 58000 -
4	Install and finish drywall	1	Lump Sum	85000	\$ 85000 -
TOTAL BID LRHC Remodel					\$ 288,000 -

ADDITIVE / ALTERNATE

No.	Item	Quantity	Unit of Measure	Unit Price or Lump Sum Price Figures	Total
1A					\$ -

Name of Firm Becmen LLC

Name (Print) Josif Bec

Signature Josif Bec

Date 5/23/2024

Digitally signed by Josif Bec
Date: 2024.05.23 13:28:20 -0700

FIRST-TIER SUBCONTRACTOR DISCLOSURE FORM
PROJECT: BID# 2024-31 Metal Framing, Insulation, and Drywall for Lake Road Health Center

BID OPENING: May 23, 2024, 2:00 PM, Pacific Time

Failure to submit this Form by the disclosure deadline will result in a nonresponsive bid.

INSTRUCTIONS:

This First-Tier Subcontractor Disclosure Form ("Form") must be submitted and received at the location specified in the Notice of Public Improvement Contract Opportunity on the advertised Bid Closing, and within two working hours after the advertised Bid Closing Time.

Proposals will only be accepted electronically thru a secure online bid submission service, **Bid Locker**. *Email submissions to Clackamas County email addresses will no longer be accepted.*

- A. Completed proposal documents must arrive electronically via Bid Locker located at <https://bidlocker.us/a/clackamascounty/BidLocker>.
- B. Bid Locker will electronically document the date and time of all submissions. Completed documents must arrive by the deadline indicated in Section 1 or as modified by Addendum. **LATE PROPOSALS WILL NOT BE ACCEPTED.**
- C. Proposers must register and create a profile for their business with Bid Locker in order to submit for this project. It is free to register for Bid Locker.
- D. Proposers with further questions concerning Bid Locker may review the Vendor's Guide located at <https://www.clackamas.us/how-to-bid-on-county-projects>.

Subcontractor lists may be submitted with the bid in the same envelope or email at the Bid Closing date and time. Subcontractor lists **MUST** be submitted within **two (2) hours** of the Bid Closing date and time.

List below the name of each subcontractor that will be furnishing labor, or labor and materials, for which disclosure is required, the category of work that the subcontractor will be performing, and the dollar value of the subcontract. Enter "**NONE**" if the value of the project bid is less than \$100,000 or there are no subcontractors that need to be disclosed. **ATTACH ADDITIONAL SHEETS IF NECESSARY.**

	SUBCONTRACTOR NAME	DOLLAR VALUE	CATEGORY OF WORK
1.	_____	_____	_____
2.	<u>NONE</u>	_____	<u>NONE</u>
3.	_____	<u>NONE</u>	_____
4.	_____	_____	_____
5.	_____	_____	_____
6.	_____	_____	_____

The above listed first-tier subcontractor(s) are providing labor, or labor and material, with a Dollar Value equal to or greater than:

- a) 5% of the total Contract Price, but at least \$15,000. If the Dollar Value is less than \$15,000 do not list the subcontractor above; or
- b) \$350,000 regardless of the percentage of the total Contract Price.

Firm Name: BECMEN LLC

Bidder Signature: Jerry Bec Phone # 503-515-4287



**CLACKAMAS COUNTY
PUBLIC IMPROVEMENT CONTRACT
SUPPLEMENTAL GENERAL CONDITIONS**

PROJECT: 2024-31 Metal Framing, Insulation, and Drywall for Lake Road Health Center

The following modifies the October 13, 2021 Clackamas County General Conditions for Public Improvement Contracts (“County General Conditions”) for this Contract. Except as modified below, all other terms and conditions of the County General Conditions shall remain in effect.

1. Good Faith Effort

As a condition of Contractor being awarded a Contract for this Project, Contractor must complete Good Faith Effort outreach and documentation as described in the Supplemental Instructions to Bidders of the Solicitation Document.

The Contractor may not change who is performing each Division of Work identified in Form 1 of the Good Faith Effort without the express written advance approval of Owner. This includes substituting identified subcontractors, self-performance of a Division of Work that was identified to be performed by a subcontractor, or the Contractor subcontracting a Division of Work that was identified to be self-performed by the Contractor.

Contractor shall be required to submit the completed Form 3 with its final pay application as a condition of final payment.



CLACKAMAS COUNTY GENERAL CONDITIONS FOR PUBLIC IMPROVEMENT CONTRACTS October 13, 2021

INSTRUCTIONS: The attached **Clackamas County General Conditions for Public Improvement Contracts ("County General Conditions")** apply to all designated Public Improvement contracts. Changes to the County General Conditions (including any additions, deletions or substitutions) should only be made by attaching Public Improvement Supplemental General Conditions. The text of these County General Conditions should not otherwise be altered.

TABLE OF SECTIONS

SECTION A - GENERAL PROVISIONS

- A.1 DEFINITION OF TERMS
- A.2 SCOPE OF WORK
- A.3 INTERPRETATION OF CONTRACT DOCUMENTS
- A.4 EXAMINATION OF PLANS, SPECIFICATIONS, AND PROJECT
- A.5 INDEPENDENT CONTRACTOR STATUS
- A.6 RETIREMENT SYSTEM STATUS AND TAXES
- A.7 GOVERNMENT EMPLOYMENT STATUS

SECTION B - ADMINISTRATION OF THE CONTRACT

- B.1 OWNER'S ADMINISTRATION OF THE CONTRACT
- B.2 CONTRACTOR'S MEANS AND METHODS
- B.3 MATERIALS AND WORKMANSHIP
- B.4 PERMITS
- B.5 COMPLIANCE WITH GOVERNMENT REGULATIONS
- B.6 SUPERINTENDENCE
- B.7 INSPECTION
- B.8 SEVERABILITY
- B.9 ACCESS TO RECORDS
- B.10 WAIVER
- B.11 SUBCONTRACTS AND ASSIGNMENT
- B.12 SUCCESSORS IN INTEREST
- B.13 OWNER'S RIGHT TO DO WORK
- B.14 OTHER CONTRACTS

SECTION C - WAGES AND LABOR

- C.1 MINIMUM WAGES RATES ON PUBLIC WORKS
- C.2 PAYROLL CERTIFICATION AND FEE REQUIREMENTS, ADDITIONAL RETAINAGE
- C.3 PROMPT PAYMENT AND CONTRACT CONDITIONS
- C.4 PAYMENT FOR MEDICAL CARE
- C.5 HOURS OF LABOR

SECTION D - CHANGES IN THE WORK

- D.1 CHANGES IN THE WORK
- D.2 DELAYS
- D.3 CLAIMS REVIEW PROCESS

SECTION E - PAYMENTS

- E.1 SCHEDULE OF VALUES
- E.2 APPLICATIONS FOR PAYMENT
- E.3 PAYROLL CERTIFICATION REQUIREMENT
- E.4 DUAL PAYMENT SOURCES
- E.5 RETAINAGE
- E.6 FINAL PAYMENT

SECTION F - PROJECT SITE CONDITIONS

- F.1 USE OF PREMISES
- F.2 PROTECTION OF WORKERS, PROPERTY, AND THE PUBLIC
- F.3 CUTTING AND PATCHING
- F.4 CLEANING UP
- F.5 ENVIRONMENTAL CONTAMINATION
- F.6 ENVIRONMENTAL CLEAN-UP

SECTION G - INDEMNITY, BONDING AND INSURANCE

- G.1 RESPONSIBILITY FOR DAMAGES/INDEMNITY
- G.2 PERFORMANCE AND PAYMENT SECURITY, PUBLIC WORKS BOND
- G.3 INSURANCE

SECTION H - SCHEDULE OF WORK

- H.1 CONTRACT PERIOD
- H.2 SCHEDULE
- H.3 PARTIAL OCCUPANCY OR USE

SECTION I - CORRECTION OF WORK

- I.1 CORRECTIONS OF WORK BEFORE FINAL PAYMENT
- I.2 WARRANTY WORK

SECTION J - SUSPENSION AND/OR TERMINATION OF THE WORK

- J.1 OWNER'S RIGHT TO SUSPEND THE WORK
- J.2 CONTRACTOR'S RESPONSIBILITIES
- J.3 COMPENSATION FOR SUSPENSION
- J.4 OWNER'S RIGHT TO TERMINATE CONTRACT
- J.5 TERMINATION FOR CONVENIENCE, NON-APPROPRIATION OF FUNDS, OR FORCE MAJEURE
- J.6 ACTION UPON TERMINATION

SECTION K - CONTRACT CLOSE-OUT

- K.1 RECORD DOCUMENTS
- K.2 OPERATION AND MAINTENANCE MANUALS
- K.3 COMPLETION NOTICES
- K.4 TRAINING
- K.5 EXTRA MATERIALS
- K.6 ENVIRONMENTAL CLEAN-UP
- K.7 CERTIFICATE OF OCCUPANCY
- K.8 OTHER CONTRACTOR RESPONSIBILITIES
- K.9 SURVIVAL

SECTION L - GENERAL PROVISIONS

- L.1 NO THIRD PARTY BENEFICIARIES
- L.2 SEVERABILITY
- L.3 ACCESS TO RECORDS
- L.4 WAIVER
- L.5 SUCCESSORS IN INTEREST
- L.6 GOVERNING LAW
- L.7 APPLICABLE LAW
- L.8 NON-EXCLUSIVE RIGHTS & REMEDIES
- L.9 INTERPRETATION
- L.10 DEBT LIMITATION
- L.11 LITIGATION
- L.12 SURVIVAL
- L.13 ACCESS TO RECORDS
- L.14 WAIVER
- L.15 NO ATTORNEY FEES

**CLACKAMAS COUNTY GENERAL CONDITIONS
FOR PUBLIC IMPROVEMENT CONTRACTS
("County General Conditions")**

**SECTION A
GENERAL PROVISIONS**

A.1 DEFINITION OF TERMS

In the Contract Documents the following terms shall be as defined below:

APPLICABLE LAWS, means all federal, state and local laws, codes, rules, regulations and ordinances, as amended applicable to the Work, to the Contract, or to the parties individually.

APPROVED BY CONTRACTING AGENCY, for purposes of ORS 279C.570(2), means the date a progress payment is approved by the Clackamas County Treasurer's office.

ARCHITECT/ENGINEER, means the Person appointed by the Owner to make drawings and specifications and, to provide contract administration of the Work contemplated by the Contract to the extent provided herein or by supplemental instruction of Owner (under which Owner may delegate responsibilities to the Architect/Engineer), in accordance with ORS Chapter 671 (Architects) or ORS Chapter 672 (Engineers) and administrative rules adopted thereunder.

AVOIDABLE DELAYS, mean any delays other than Unavoidable Delays, and include delays that otherwise would be considered Unavoidable Delays but that: (a) Could have been avoided by the exercise of care, prudence, foresight, and diligence on the part of the Contractor or its Subcontractors; (b) Affect only a portion of the Work and do not necessarily prevent or delay the prosecution of other parts of the Work nor the completion of the whole Work within the Contract Time; (c) Do not impact activities on the accepted critical path schedule; and (d) Are associated with the reasonable interference of other contractors employed by the Owner that do not necessarily prevent the completion of the whole Work within the Contract Time.

BIDDER, means a bidder in connection with Instructions to Bidders or a proposer in connection with a Request for Proposals, or Solicitation Document. May also be referenced as "Offeror," "Quoter" or "Proposer" based on the type of Solicitation Document.

CHANGE ORDER, means a written order which, when fully executed by the Parties to the Contract, constitutes a change to the Contract Documents. Change Orders shall be issued in accordance with the changes provisions in Section D and, if applicable, establish a Contract Price or Contract Time adjustment. A Change Order shall not be effective until executed by both parties.

CLAIM, means a demand by Contractor pursuant to Section D.3 for review of the denial of Contractor's initial request for an adjustment of Contract terms, payment of money, extension of Contract Time or other relief, submitted in accordance with the requirements and within the time limits established for review of Claims in these County General Conditions.

CONTRACT, means the written agreement between the Owner and the Contractor comprised of the Contract Documents which describe the Work to be done and the obligations between the parties.

CONTRACT DOCUMENTS, means the Contract, County General Conditions, Supplemental General Conditions if any, Plans, Specifications, the accepted Offer, Solicitation Document and addenda thereto, Instructions to Offerors, and Supplemental Instructions to Offerors.

CONTRACT PERIOD, as set forth in the Contract Documents, means the total period of time beginning with the full execution of a Contract

and, if applicable, the issuance of a Notice to Proceed and concluding upon Final Completion.

CONTRACT PRICE, means the total price reflected in the Contract.

CONTRACT TIME, means any incremental period of time allowed under the Contract to complete any portion of the Work as reflected in the Project schedule.

CONTRACTOR, means the Person awarded the Contract for the Work contemplated.

DAYS, are calendar days, including weekdays, weekends and holidays, unless otherwise specified.

DEFECTIVE WORK, means Work that is not completed in accordance with the Specifications or the requirements of the Contract.

DIRECT COSTS, means, unless otherwise provided in the Contract Documents: the cost of materials, including sales tax and the cost of delivery; cost of labor which shall only include the applicable prevailing wage and fringe benefit (if applicable, and if paid to or on behalf of the employee) rate plus a maximum of a twelve percent (12%) markup on the prevailing wage (but not the fringe benefit) to cover Contractor's labor burden including but not limited to social security, Medicare, unemployment insurance, workers' compensation insurance, sick leave pay; substantiated Project cost increases for specific insurance (including, without limitation, Builder's Risk Insurance and Builder's Risk Installation Floater) or bond premiums; rental cost of equipment, and machinery required for execution of the Work; and the additional costs of field personnel directly attributable to the Work; travel expense reimbursement only if specifically authorized and only to the extent allowable under the County Contractor Travel Reimbursement Policy, hereby incorporated by reference.

FINAL COMPLETION, means the final completion of all requirements under the Contract, including Contract Closeout as described in Section K but excluding Warranty Work as described in Section I.2, and the final payment and release of all retainage, if any.

FORCE MAJEURE, means an act, event or occurrence caused by fire, riot, war, acts of God, terrorism, nature, sovereign, or public enemy, strikes, freight embargoes or any other act, event or occurrence that is beyond the control of the party to the Contract who is asserting Force Majeure.

NOTICE TO PROCEED, means the official written notice from the Owner stating that the Contractor is to proceed with the Work defined in the Contract Documents.

OFFER, means a bid in connection with Instructions to Bidders or a proposal in connection with a Request for Proposals, or Solicitation Document to do the work stated in the Solicitation Document at the price quoted. May also be referenced as "Bid," "Quote," or "Proposal" based on the type of Solicitation Document.

OVERHEAD, means those items which may be included in the Contractor's markup (general and administrative expense and profit) and that shall not be charged as Direct Cost of the Work, including without limitation such Overhead expenses as wages or salary of personnel above the level of foreman (i.e., superintendents and project managers), labor rates and fringe benefits above the applicable prevailing wage and fringe benefit (if applicable, and if paid to or on behalf of the employee), Contractor's labor burden for fringe benefit if paid to the employee, expenses of Contractor's offices and supplies at the Project Site (e.g. job trailer) and at Contractor's principal place of business and including expenses of personnel staffing the Project Site office and Contractor's principal place of business, and Commercial General Liability Insurance and Automobile Liability Insurance.

OWNER, means, Clackamas County or any component unit thereof including Clackamas County Development Agency, Clackamas County Service District No. 1, Surface Water Management Agency of Clackamas County, Tri-City Service District, Water Environment Services, North Clackamas Parks and Recreation District, Clackamas County Extension & 4-H Service District, Library Service District of Clackamas County, Enhanced Law Enforcement District, and Clackamas County Service District No. 5. Owner may elect, by written notice to Contractor, to delegate certain duties to more than one agent, including without limitation, to an Architect/Engineer. However, nothing in these County General Conditions is intended to abrogate the separate design professional responsibilities of Architects under ORS Chapter 671 or of Engineers under ORS Chapter 672.

PERSON, means a natural person or entity doing business as a sole proprietorship, a partnership, a joint venture, a corporation, a limited liability company or partnership, a nonprofit, a trust, or any other entity possessing the legal capacity to contract.

PLANS, means the drawings which show the location, type, dimensions, and details of the Work to be done under the Contract.

PRODUCT DATA, means illustrations, standard schedules, performance charts, instructions, brochures, diagrams and other information furnished by the Contractor to illustrate materials or equipment for some portion of the Work.

PROJECT, means the total undertaking to be accomplished for Owner by architects/engineers, contractors, and other others, including planning, study, design, construction, testing, commissioning, start-up, of which the Work to be performed under the Contract Documents is a part.

PROJECT SITE, means the specific real property on which the Work is to be performed, including designated contiguous staging areas, that is identified in the Plans, Specifications and Drawings.

PUNCH LIST, means the list of Work yet to be completed or deficiencies which need to be corrected in order to achieve Final Completion of the Contract.

RECORD DOCUMENT, means the as-built Plans, Specifications, testing and inspection records, product data, samples, manufacturer and distributor/supplier warranties evidencing transfer of ownership to Owner, operational and maintenance manuals, shop drawings, correspondence, certificate(s) of occupancy, and other documents listed in Subsection B.9.1 of these County General Conditions, recording all Services performed.

SAMPLES, means physical examples which illustrate materials, equipment or workmanship and establish standards by which the Work will be judged.

SHOP DRAWINGS, means drawings, diagrams, schedules and other data specially prepared for the Work by the Contractor or a Subcontractor (including any subsubcontractor), manufacturer, supplier, or distributor to illustrate some portion of the Work.

SOLICITATION DOCUMENT, means an Invitation to Bid, Request for Proposals, Request for Quotes, or other written document issued by Owner that outlines the required Specifications necessary to submit an Offer.

SPECIFICATION, means any description of the physical or functional characteristics of the Work, or of the nature of a supply, service or construction item included in the Solicitation Document. Specifications may include a description of any requirement for inspecting, testing or preparing a supply, service or construction item for delivery and the quantities or qualities of materials to be furnished under the Contract. Specifications generally will state the results or products to be obtained and may, on occasion, describe the method and manner of doing the

Work to be performed. Specifications may be incorporated by reference and/or may be attached to the Contract.

SUBCONTRACTOR, means a Person having a direct contract with the Contractor, or another Subcontractor of any tier, to perform one or more items of the Work.

SUBSTANTIAL COMPLETION, means the date when the Owner accepts in writing the construction, alteration or repair constituting the Work or any designated portion thereof as having reached that state of completion when it may be used or occupied for its intended purpose. Substantial Completion of facilities with operating systems occurs only after thirty (30) continuous Days of successful, trouble-free operation of the operating systems as provided in Section K.3.2.

SUBSTITUTIONS, means items that in function, performance, reliability, quality, and general configuration are the same or better than the product(s) specified. Substitutions also means the performance of the Work by a labor force other than what is submitted in the Offer.

SUPPLEMENTAL GENERAL CONDITIONS, means those conditions that remove from, add to, or modify these County General Conditions. Public Improvement Supplemental General Conditions may be included in the Solicitation Document or may be a separate attachment to the Contract.

UNAVOIDABLE DELAYS, mean delays other than Avoidable Delays that are: (a) to the extent caused by any actions of the Owner, or any other employee or agent of the Owner, or by a separate contractor employed by the Owner; (b) to the extent caused by any Project Site conditions which differ materially from the conditions that would normally be expected to exist and inherent to the construction activities defined in the Contract Documents; or (c) to the extent caused by Force Majeure acts, or events or occurrences.

WORK, means the furnishing of all materials, equipment, labor, transportation, services, incidentals, those permits and regulatory approvals not provided by the owner necessary to successfully complete any individual item or the entire Contract and the carrying out of duties and obligations imposed by the Contract Documents for the Project.

A.2 SCOPE OF WORK

The Work contemplated under the Contract includes all labor, materials, transportation, equipment and services for, and incidental to, the completion of all work in connection with the Project described in the Contract Documents. The Contractor shall perform all Work necessary so that the Project can be legally occupied and fully used for the intended use as set forth in the Contract Documents.

A.3 INTERPRETATION OF CONTRACT DOCUMENTS

A.3.1 Unless otherwise specifically defined in the Contract Documents, words which have well-known technical meanings or construction industry meanings are used in the Contract Documents in accordance with such recognized meanings. Contract Documents are intended to be complementary. Whatever is called for in one, is interpreted to be called for in all. However, in the event of conflicts or discrepancies among the Contract Documents, interpretations will be based on the following descending order of precedence:

- (a) The Contract and any amendments thereto, including Change Orders, with those of later date having precedence over those of an earlier date;
- (b) The Supplemental General Conditions;
- (c) County General Conditions;
- (d) Plans and Specifications;
- (e) The Solicitation Document, and any addenda thereto.

A.3.2 In the case of an inconsistency between Plans and Specifications or within either document not clarified by addendum, the better quality or greater quantity of Work shall be provided in accordance with the Owner's interpretation in writing as determined in Owners sole discretion.

A.3.3 If the Contractor finds discrepancies in, or omissions from the Contract Documents, or if the Contractor is in doubt as to their meaning, the Contractor shall at once notify the Owner. Matters concerning and interpretation of requirements of the Contract Documents will be decided by the Owner in the Owner's sole discretion, who may delegate that duty in some instances to the Architect/Engineer. Responses to Contractor's requests for interpretation of Contract Documents will be made in writing by Owner (or the Architect/Engineer) within any time limits agreed upon or otherwise with reasonable promptness. Contractor shall not proceed without direction in writing from the Owner (or Architect/Engineer).

A.3.4 References to standard specifications, manuals, codes of any technical society, organization or association, to the laws or regulations of any governmental authority, whether such reference be specific or by implication, shall mean the latest standard specification, manual, code, laws or regulations in effect in the jurisdiction where the Project Site is located on the first published date of the Solicitation Document, except as may be otherwise specifically stated.

A.4 EXAMINATION OF PLANS, SPECIFICATIONS, AND PROJECT SITE

A.4.1 It is understood that the Contractor, before submitting an Offer, has made a careful examination of the Contract Documents; has become fully informed as to the quality and quantity of materials and the character of the Work required; and has made a careful examination of the location and conditions of the Work and the sources of supply for materials. The Owner will in no case be responsible for any loss or for any unanticipated costs that may be suffered by the Contractor as a result of the Contractor's failure to acquire full information in advance in regard to all conditions pertaining to the Work. No oral agreement or conversation with any officer, agent, or personnel of the Owner, or with the Architect/Engineer either before or after the execution of the Contract, shall affect or modify any of the terms or obligations herein contained. Contractor shall at all times be responsible for all utility locates regardless of the ownership of such utility infrastructure or service.

A.4.2 Should the Plans or Specifications fail to particularly describe the materials, kind of goods, or details of construction of any aspect of the Work, Contractor shall have the duty to make inquiry of the Owner and Architect/Engineer as to what is required prior to performance of the Work. Absent Specifications to the contrary, the materials or processes that would normally be used to produce first quality finished Work shall be considered a part of the Contract requirements.

A.4.3 Any design errors or omissions noted by the Contractor shall be reported promptly to the Owner, including without limitation, any nonconformity with Applicable Laws.

A.4.4 If the Contractor believes that adjustments to cost or Contract Time are involved because of clarifications or instructions issued by the Owner (or Architect/Engineer) in response to the Contractor's notices or requests for information, the Contractor must submit a written request to the Owner, setting forth the nature and specific extent of the request, including all time and cost impacts against the Contract as soon as possible, but no later than thirty (30) Days after receipt by Contractor of the clarifications or instructions issued. If the Owner denies Contractor's request for additional compensation, additional Contract Time, or other relief

that Contractor believes results from the clarifications or instructions, the Contractor may proceed to file a Claim under Section D.3, Claims Review Process. If the Contractor fails to perform the obligations of Sections A.4.1 to A.4.3, the Contractor shall pay such costs and damages to the Owner as would have been avoided if the Contractor had performed such obligations.

A.4.5 If the Contractor believes that adjustments to cost or Contract Time are involved because of an Unavoidable Delay caused by differing Project Site conditions, the Contractor shall notify the Owner immediately of differing Project Site conditions before the area has been disturbed. The Owner will investigate the area and make a determination as to whether or not the conditions differ materially from either the conditions stated in the Contract Documents or those which could reasonably be expected in execution of this particular Contract. If Contractor and the Owner agrees that a differing Project Site condition exists, any adjustment to compensation or Contract Time will be determined based on the process set forth in Section D.2.2 for adjustments to or deletions from Work. If the Owner disagrees that a differing Project Site condition exists and denies Contractor's request for additional compensation or Contract Time, Contractor may proceed to file a Claim under Section D.3, Claims Review Process.

A.5 INDEPENDENT CONTRACTOR STATUS

The service or services to be performed under the Contract are those of an independent contractor as defined in ORS 670.600. Contractor represents and warrants that it is not an officer, employee or agent of the Owner as those terms are used in ORS 30.265.

A.6 RETIREMENT SYSTEM STATUS AND TAXES

Contractor represents and warrants that it is not a contributing member of the Public Employees' Retirement System and will be responsible for any federal or state taxes applicable to payment received under the Contract. Contractor will not be eligible for any benefits from these Contract payments of federal Social Security, employment insurance, workers' compensation or the Public Employees' Retirement System, except as a self-employed individual. Unless the Contractor is subject to backup withholding, Owner will not withhold from such payments any amount(s) to cover Contractor's federal or state tax obligations.

A.7 GOVERNMENT EMPLOYMENT STATUS

A.7.1 If this payment is to be charged against federal funds, Contractor represents and warrants that it is not currently employed by the Federal Government. This does not preclude the Contractor from holding another contract with the Federal Government.

SECTION B ADMINISTRATION OF THE CONTRACT

B.1 OWNER'S ADMINISTRATION OF THE CONTRACT

B.1.1 The Owner shall administer the Contract as described in the Contract Documents throughout the term of the Contract, including the one-year period for correction of Work. The Owner will act as provided in the Contract Documents, unless modified in writing in accordance with other provisions of the Contract. In performing these tasks, the Owner may rely on the Architect/Engineer or other agents to perform some or all of these tasks.

B.1.2 The Owner may visit the Project Site at intervals appropriate to the stage of the Contractor's operations (1) to become generally familiar with and to keep the Owner informed about the progress and quality of the portion of the Work completed, (2) to endeavor to guard the Owner against defects and deficiencies in the Work, and (3) to determine in general if Work is being performed in a manner indicating that the Work, when fully completed, will be in accordance with the Contract Documents. The Owner will not

make exhaustive or continuous on-Project Site inspections to check the quality or quantity of the Work. Unless otherwise required in a Change Order, the Owner will neither have control over or charge of, nor be responsible for the construction means, methods, techniques, sequences or procedures, or for the safety precautions and programs in connection with the Work.

B.1.3 Except as otherwise provided in the Contract Documents or when direct communications have been specifically authorized, the Owner and Contractor shall communicate with each other within a reasonable time frame about matters arising out of or relating to the Contract. Communications by and with the Architect/Engineer's consultants shall be through the Architect/Engineer. Communications by and with Subcontractors and material suppliers shall be through the Contractor. Communications by and with separate contractors shall be through the Owner.

B.1.4 Based upon the Architect/Engineer's evaluations of the Contractor's Application for Payment, or unless otherwise stipulated by the Owner, the Architect/Engineer will review and certify the amounts due the Contractor and will issue Certificates for Payment in such amounts.

B.2 CONTRACTOR'S MEANS AND METHODS; MITIGATION OF IMPACTS

B.2.1 The Contractor shall supervise and direct the Work, using the Contractor's best skill and attention. The Contractor shall be solely responsible for and have control over construction means, methods, techniques, sequences and procedures and for coordinating all portions of the Work under the Contract, unless the Contract Documents give other specific instructions concerning these matters. If the Contract Documents give specific instructions concerning construction means, methods, techniques, sequences or procedures, the Contractor shall evaluate the Project Site safety thereof and, except as stated below, shall be fully and solely responsible for the Project Site safety of such means, methods, techniques, sequences or procedures.

B.2.2 The Contractor is responsible to protect and maintain the Work during the course of construction and to mitigate any adverse impacts to the Project, including those caused by authorized changes, which may affect cost, schedule, or quality.

B.2.3 The Contractor is responsible for the actions of all its personnel, laborers, suppliers, agents, and Subcontractors on the Project. The Contractor shall enforce strict discipline and good order among Contractor's employees and other persons carrying out the Work. The Contractor shall not permit employment of persons who are unfit or unskilled for the tasks assigned to them.

B.3 MATERIALS AND WORKMANSHIP

B.3.1 The intent of the Contract Documents is to provide for the construction and completion of every detail of the Work described. All Work shall be performed in a professional manner and, unless the means or methods of performing a task are specified elsewhere in the Contract Documents, Contractor shall employ methods that are generally accepted and used by the industry, in accordance with industry standards.

B.3.2 The Contractor is responsible to perform the Work as required by the Contract Documents. Defective Work shall be corrected at the Contractor's sole expense and within a reasonable time frame.

B.3.3 Work done and materials furnished may be subject to inspection and/or observation and testing by the Owner to determine if they conform to the Contract Documents. Inspection of the Work by the Owner does not relieve the Contractor of responsibility for the Work in accordance with the Contract Documents.

B.3.4 Contractor shall furnish adequate facilities, as required, for the Owner to have safe access to the Work including without limitation walkways, railings, ladders, tunnels, and platforms. Producers, suppliers, and fabricators shall also provide proper facilities and access to their facilities.

B.3.5 The Contractor shall furnish Samples of materials for testing by the Owner and include the cost of the Samples in the Contract Price.

B.4 PERMITS

Contractor shall obtain and pay for all necessary permits, licenses and fees, except for those specifically excluded in the Supplemental General Conditions, as required for the project. Contractor shall be responsible for all violations of the law. Contractor shall give all requisite notices to public authorities.

B.5 COMPLIANCE WITH GOVERNMENT REGULATIONS

B.5.1 Contractor shall comply with Applicable Laws, as amended pertaining to the Work and the Contract. Failure to comply with such requirements shall constitute a breach of Contract and shall be grounds for Contract termination. Without limiting the generality of the foregoing, Contractor expressly agrees to comply with the following, as applicable and as may be amended from time to time: (i) Title VI and VII of Civil Rights Act of 1964, as amended; (ii) Section 503 and 504 of the Rehabilitation Act of 1973, as amended; (iii) the Health Insurance Portability and Accountability Act of 1996; (iv) the Americans with Disabilities Act of 1990, as amended; (v) ORS Chapter 659A; as amended; (vi) all regulations and administrative rules established pursuant to any applicable laws; and (vii) all other applicable requirements of federal, state, county or other local government entity statutes, rules and regulations.

B.5.2 Contractor shall comply with all applicable requirements of federal and state civil rights and rehabilitation statutes, rules and regulations, and

(a) Contractor shall not discriminate against Disadvantaged, Minority, Women or Emerging Small Business enterprises, as those terms are defined in ORS 200.005, or a business enterprise that is owned or controlled by or that employs a disabled veteran, as that term is defined in ORS 408.225, in the awarding of subcontracts.

(b) Contractor shall maintain, in current and valid form, all licenses and certificates required by Applicable Laws or the Contract when performing the Work.

B.5.3 Contractor shall certify that it shall not accept a bid from Subcontractors to perform Work unless such Subcontractors are registered with the Construction Contractors Board in accordance with ORS 701.021 at the time they submit their bids to the Contractor.

B.5.4 Contractor shall certify that each landscape contracting business, as defined in ORS 671.520(2), performing Work under the Contract holds a valid landscape construction professional license issued pursuant to ORS 671.560.

B.5.5 The following notice is applicable to Contractors who perform excavation Work. ATTENTION: Oregon law requires you to follow rules adopted by the Oregon Utility Notification Center. Those rules are set forth in OAR 952-001-0010 through OAR 952-001-0090. You may obtain copies of the rules by calling the center at (877) 668-4001.

B.5.6 Failure to comply with any or all of the requirements of B.5.1 through B.5.5 shall be a material breach of Contract and constitute

grounds for Contract termination. Damages or costs resulting from such noncompliance shall be the responsibility of Contractor.

B.5.7 The Contractor shall include in each subcontract those provisions required under ORS 279C.580.

B.5.8 Contractor shall comply with ORS 652.220, compliance of which is a material element of this Contract and failure to comply is a material breach that entitles County to exercise any rights and remedies available under this Contract including, but not limited to, termination for default.

B.6 SUPERINTENDENCE

Contractor shall keep on the Project Site, during the progress of the Work, a competent superintendent and any necessary assistants who shall be satisfactory to the Owner and who shall represent the Contractor on the Project Site. Directions given to the superintendent by the Owner shall be confirmed in writing to the Contractor.

B.7 INSPECTION

B.7.1 Owner shall have access to the Work at all times.

B.7.2 Inspection of the Work will be made by the Owner at its discretion. The Owner will have authority to reject Work that does not conform to the Contract Documents in the Owner's sole discretion. Any Work found to be not in conformance with the Contract Documents, in the discretion of the Owner, shall be removed and replaced at the Contractor's expense.

B.7.3 Contractor shall make or obtain at the appropriate time all tests, inspections and approvals of portions of the Work required by the Contract Documents or by Applicable Laws or orders of public authorities having jurisdiction. Unless otherwise provided, the Contractor shall make arrangements for such tests, inspections and approvals with an independent testing laboratory or entity acceptable to the Owner, or with the appropriate public authority, and shall bear all related costs of tests, inspections and approvals. Tests or inspections conducted pursuant to the Contract Documents shall be made promptly to avoid unreasonable delay in the Work. The Contractor shall give the Owner timely notice of when and where tests and inspections are to be made so that the Owner may be present for such procedures. Required certificates of testing, inspection or approval shall, unless otherwise required by the Contract Documents, be secured by the Contractor and promptly delivered to the Owner.

B.7.4 As required by the Contract Documents, Work done or material used without required inspection or testing and/or without providing timely notice to the Owner may be ordered removed at the Contractor's expense.

B.7.5 If directed to do so by Owner or other permitting authority any time before the Work is accepted, the Contractor shall uncover portions of the completed Work for inspection. After inspection, the Contractor shall restore such portions of Work to the standard required by the Contract. If the Work uncovered is unacceptable or was done without required testing or inspection or sufficient notice to the Owner, the uncovering and restoration shall be done at the Contractor's expense. If the Work uncovered is acceptable and was done with sufficient notice to the Owner, the uncovering and restoration will be paid for pursuant to a Change Order.

B.7.6 If any testing or inspection reveals failure of the portions of the Work to comply with requirements established by the Contract Documents, all costs made necessary by such failure, including those of repeated procedures and compensation for the Owner's and Architect/Engineer's services and expenses, shall be at the Contractor's expense.

B.7.7 In Owner's sole discretion, it may authorize other interested parties to inspect the Work affecting their interests or property. Their right to inspect shall not make them a party to the Contract and shall not interfere with the rights of the parties of the Contract. Instructions or orders of such parties shall be transmitted to the Contractor, through the Owner.

B.8 SUBCONTRACTS AND ASSIGNMENT

B.8.1 Contractor shall require each Subcontractor, to the extent of the Work to be performed by the Subcontractor, to be bound by the terms and conditions of these General Conditions and Supplemental General Conditions, and to assume toward the Contractor all of the obligations and responsibilities which the Contractor assumes toward the Owner thereunder, unless (1) the same are clearly inapplicable to the subcontract at issue because of legal requirements or industry practices, or (2) specific exceptions are requested by Contractor and approved in writing by Owner. Where appropriate, Contractor shall require each Subcontractor to enter into similar agreements with sub-subcontractors at any level.

B.8.2 At Owner's request, Contractor shall submit to Owner prior to their execution either Contractor's form of subcontract, or the subcontract to be executed with any particular Subcontractor. If Owner disapproves such form, Contractor shall not execute the form until the matters disapproved are resolved to Owner's satisfaction. Owner's review, comment upon or approval of any such form shall not relieve Contractor of its obligations under this Agreement or be deemed a waiver of such obligations of Contractor.

B.8.3 Contractor shall not assign, sell, or transfer its rights, or delegate its responsibilities under the Contract, in whole or in part, without the prior written approval of the Owner. No such written approval shall relieve Contractor of any obligations of the Contract, and any transferee shall be considered the agent of the Contractor and bound to perform in accordance with the Contract Documents. Contractor shall remain liable as between the original parties to the Contract as if no assignment had occurred.

B.9 OWNER'S RIGHT TO DO WORK

Owner reserves the right to perform other or additional work at or near the Project Site with other agents than those of the Contractor. If such work takes place within or next to the Project Site, Contractor shall coordinate work with the other contractors or agents, cooperate with all other contractors or forces, carry out the Work in a way that will minimize interference and delay for all agents involved, place and dispose of materials being used so as not to interfere with the operations of another, and join the Work with the work of the others in an acceptable manner and perform it in proper sequence to that of the others. The Owner will resolve any disagreements that may arise between or among Contractor and the other contractors over the method or order of doing all work (including the Work). In case of unavoidable interference, the Owner will establish work priority (including the Work) in the Owner's sole discretion.

B.10 OTHER CONTRACTS

In all cases and at any time, the Owner has the right to execute other contracts related to or unrelated to the Work of the Contract. The Contractor of the Contract shall fully cooperate with any and all other contractors without additional cost to the Owner in the manner described in Section B.13.

B.11 ALLOWANCES

B.11.1 The Contractor shall include in the Contract Price all allowances stated in the Contract Documents. Items covered by allowances

shall be supplied for such amounts and by such persons or entities as the Owner may direct.

- B.11.2 Unless otherwise provided in the Contract Documents:
- (a) when finally reconciled, allowances shall cover the cost of the Contractor's materials and equipment delivered at the Project Site and all required taxes, less applicable trade discounts;
 - (b) Contractor's costs for unloading and handling at the Project Site, labor, installation costs, Overhead, profit and other expenses contemplated for stated allowance amounts shall be included in the Contract Price but not in the allowances;
 - (c) whenever costs are more than or less than allowances, the Contract Price shall be adjusted accordingly by Change Order. The amount of the Change Order shall reflect (i) the difference between actual costs and the allowances under Section B.17.2(a) and (ii) changes in Contractor's costs under Section B.17.2(b);
 - (d) Unless Owner requests otherwise, Contractor shall provide to Owner a proposed fixed price for any allowance work prior to its performance.

B.12 SUBMITTALS, SHOP DRAWINGS, PRODUCT DATA AND SAMPLES

- B.12.1 The Contractor shall prepare and keep current, for the Architect's/Engineer's approval (or for the approval of Owner if approval authority has not been delegated to the Architect/Engineer), a schedule and list of submittals which is coordinated with the Contractor's construction schedule and allows the Architect/Engineer reasonable time to review submittals. Owner reserves the right to finally approve the schedule and list of submittals. Submittals include, without limitation, Shop Drawings, Product Data, and Samples.
- B.12.2 Shop Drawings, Product Data, Samples and similar submittals are not Contract Documents. The purpose of their submittal is to demonstrate for those portions of the Work for which submittals are required by the Contract Documents the way by which the Contractor proposes to conform to the information given and the design concept expressed in the Contract Documents. Review of submittals by the Architect/Engineer is not conducted for the purpose of determining the accuracy and completeness of other details such as dimensions and quantities, or for substantiating instructions for installation or performance of equipment or systems, or for approval of safety precautions or, unless otherwise specifically stated by the Architect/Engineer, of any construction means, methods, techniques, sequences or procedures, all of which remain the responsibility of the Contractor as required by the Contract Documents. The Architect/Engineer's review of the Contractor's submittals shall not relieve the Contractor of its obligations under the Contract Documents. The Architect/Engineer's approval of a specific item shall not indicate approval of an assembly of which the item is a component. Informational submittals upon which the Architect/Engineer is not expected to take responsive action may be so identified in the Contract Documents. Submittals which are not required by the Contract Documents may be returned by the Architect/Engineer without action.
- B.12.3 The Contractor shall review for compliance with the Contract Documents, approve and submit to the Architect/Engineer Shop Drawings, Product Data, Samples and similar submittals required by the Contract Documents with reasonable promptness and in such sequence as to cause no delay in the Work or in the activities of the Owner or of separate contractors. Submittals which are not marked as reviewed for compliance with the Contract Documents

and approved by the Contractor may be returned by the Architect/Engineer without action.

- B.12.4 By approving and submitting Shop Drawings, Product Data, Samples and similar submittals, the Contractor represents that the Contractor has determined and verified materials, field measurements and field construction criteria related thereto, or will do so, and has checked and coordinated the information contained within such submittals with the requirements of the Work and of the Contract Documents.
- B.12.5 The Contractor shall perform no portion of the Work for which the Contract Documents require submittal and review of Shop Drawings, Product Data, Samples or similar submittals until the respective submittal has been approved by the Architect/Engineer.
- B.12.6 The Work shall be in accordance with approved submittals except that the Contractor shall not be relieved of responsibility for deviations from requirements of the Contract Documents by the Architect/Engineer's review or approval of Shop Drawings, Product Data, Samples or similar submittals unless the Contractor has specifically informed the Architect/Engineer in writing of such deviation at the time of submittal and (i) the Architect/Engineer has given written approval to the specific deviation as a minor change in the Work, or (ii) a Change Order has been executed by Owner authorizing the deviation. The Contractor shall not be relieved of responsibility for errors or omissions in Shop Drawings, Product Data, Samples or similar submittals by the Architect/Engineer's review or approval thereof.
- B.12.7 In the event that Owner elects not to have the obligations and duties described under this Section B.18 performed by the Architect/Engineer, or in the event no Architect/Engineer is employed by Owner on the Project, all obligations and duties assigned to the Architect/Engineer hereunder shall be performed by the Owner.

B.13 SUBSTITUTIONS

The Contractor may make Substitutions only with the written consent of the Owner, after evaluation by the Owner and only in accordance with a Change Order. Substitutions shall be subject to the requirements of the Solicitation Document. By making requests for Substitutions, the Contractor represents that the Contractor has personally investigated the proposed substitute product; represents that the Contractor will provide the same warranty for the Substitution that the Contractor would for the product originally specified unless approved otherwise; certifies that the cost data presented is complete and includes all related costs under the Contract including redesign costs, and waives all claims for additional costs related to the Substitution which subsequently become apparent; and will coordinate the installation of the accepted Substitution, making such changes as may be required for the Work to be completed in all respects.

B.14 USE OF PLANS AND SPECIFICATIONS

Plans, Specifications and related Contract Documents furnished to Contractor by Owner or Owner's Architect/Engineer shall be used solely for the performance of the Work under the Contract. Contractor and its Subcontractors and suppliers are authorized to use and reproduce applicable portions of such documents appropriate to the execution of the Work, but shall not claim any ownership or other interest in them beyond the scope of the Contract, and no such interest shall attach. Unless otherwise indicated, all common law, statutory and other reserved rights, in addition to copyrights, are retained by Owner.

SECTION C
WAGES AND LABOR

C.1 PREVAILING WAGE RATES ON PUBLIC WORKS

Contractor shall comply fully with the provisions of ORS 279C.800 through 279C.870. Pursuant to ORS 279C.830(1)(d), Contractor shall pay workers at not less than the specified minimum hourly rate of wage, and shall include that requirement in all subcontracts. If the Work is subject to both the state prevailing wage rate law and the federal Davis-Bacon Act, Contractor shall pay the higher of the applicable state or federal prevailing rate of wage. Contractor shall provide written notice to all workers of the number of hours per day and days per week such workers may be required to work.

C.2 PAYROLL CERTIFICATION AND FEE REQUIREMENTS

- C.2.1 In accordance with ORS 279C.845, the Contractor and every Subcontractor shall submit written certified statements to the Owner on the form prescribed by the Commissioner of the Bureau of Labor and Industries ("BOLI"), certifying the hourly rate of wage paid each worker which the Contractor or the Subcontractor has employed on the Project and further certifying that no worker employed on the Project has been paid less than the prevailing rate of wage or less than the minimum hourly rate of wage specified in the Contract, which certificate and statement shall be verified by the oath of the Contractor or the Subcontractor that the Contractor or Subcontractor has read the certified statement, that the Contractor or Subcontractor knows the contents of the certified statement, and, that to the Contractor's or Subcontractor's best knowledge and belief, the certified statement is true. The certified statements shall set out accurately and completely the payroll records for the prior week, including the name and address of each worker, the worker's correct classification, rate of pay, daily and weekly number of hours worked, deductions made, and actual wages paid. Certified statements for each week during which the Contractor or Subcontractor has employed a worker on the Project shall be submitted once a month, by the fifth (5th) business day of the following month. The Contractor and Subcontractors shall preserve the certified statements for a period of ten (10) years from the date of completion of the Contract.
- C.2.2 Pursuant to ORS 279C.845(7), the Owner shall retain 25 percent of any amount earned by the Contractor on the Project until the Contractor has filed the certified statements required by section C.2.1. The Owner shall pay to the Contractor the amount retained under this subsection within 14 days after the Contractor files the required certified statements, regardless of whether a Subcontractor has failed to file certified statements.
- C.2.3 Pursuant to ORS 279C.845(8), the Contractor shall retain 25 percent of any amount earned by a first-tier Subcontractor on this Project until the first-tier Subcontractor has filed with the Owner the certified statements required by C.2.1. Before paying any amount retained under this subsection, the Contractor shall verify that the first-tier Subcontractor has filed the certified statement. Within 14 days after the first-tier Subcontractor files the required certified statement the Contractor shall pay the first-tier Subcontractor any amount retained under this subsection.
- C.2.4 In accordance with statutory requirements and administrative rules promulgated by the Commissioner of the Bureau of Labor and Industries, the fee required by ORS 279C.825(1) will be paid by Owner to the Commissioner.

C.3 PROMPT PAYMENT AND CONTRACT CONDITIONS

- C.3.1 As a condition to Owner's performance hereunder, the Contractor shall:
- C.3.1.1 Make payment promptly, as due, to all persons supplying to Contractor labor or materials for the prosecution of the Work provided for in the Contract.
- C.3.1.2 Pay all contributions or amounts due the State Industrial Accident Fund or successor program from such Contractor or Subcontractor incurred in the performance of the Contract.
- C.3.1.3 Not permit any lien or claim to be filed or prosecuted against the Owner on account of any labor or material furnished. Contractor will not assign any claims that Contractor has against Owner, or assign any sums due by Owner, to Subcontractors, suppliers, or manufacturers, and will not make any agreement or act in any way to give Subcontractors a claim or standing to make a claim against the Owner.
- C.3.1.4 Pay to the Department of Revenue all sums withheld from employees pursuant to ORS 316.167.
- C.3.2 If Contractor fails, neglects or refuses to make prompt payment of any claim for labor or services furnished to the Contractor of a Subcontractor by any person in connection with the Project as such claim becomes due, the proper officer(s) representing the Owner may pay the claim and charge the amount of the payment against funds due or to become due Contractor under the Contract. Payment of claims in this manner shall not relieve the Contractor or the Contractor's surety from obligation with respect to any unpaid claims.
- C.3.3 Contractor shall include in each subcontract for property or services entered into by the Contractor and a first-tier subcontractor, including a material supplier, for the purpose of performing a construction contract, a payment clause that obligates the Contractor to pay the first-tier Subcontractor for satisfactory performance under its subcontract within ten (10) Days out of such amounts as are paid to the Contractor by the Owner under such contract.
- C.3.4 If the Contractor or a first-tier subcontractor fails, neglects or refuses to pay a person that provides labor or materials in connection with the Contract within 30 days after receiving payment from the contracting agency or a contractor, the Contractor or first-tier subcontractor owes the person the amount due plus interest charges that begin at the end of the 10-day period within which payment is due under ORS 279C.580 (4) and that end upon final payment, unless payment is subject to a good faith dispute as defined in ORS 279C.580. The rate of interest on the amount due is nine percent per annum. The amount of interest may not be waived.
- C.3.5 If the Contractor or a subcontractor fails, neglects or refuses to make payment to a person furnishing labor or materials in connection with the Contract, the person may file a complaint with the Construction Contractors Board, unless payment is subject to a good faith dispute as defined in ORS 279C.580.
- C.3.6 All employers, including Contractor, that employ subject workers who work under the Contract in the State of Oregon shall comply with ORS 656.017 and provide the required Workers' Compensation coverage, unless such employers are exempt under ORS 656.126. Contractor shall ensure that each of its Subcontractors complies with these requirements.
- C.3.7 In accordance with ORS 279C.570, for all subcontracts that exceed \$500,000 that the Contractor withholds retainage, the Contractor shall place amounts deducted as retainage into an interest-bearing escrow account. Interest on the retainage amount accrues from the

date the payment request is approved until the date the retainage is paid to the Subcontractor to which it is due.

C.4 PAYMENT FOR MEDICAL CARE

As a condition to Owner's performance hereunder, Contractor shall promptly, as due, make payment to any person, co-partnership, association or corporation furnishing medical, surgical, and hospital care or other needed care and attention, incident to sickness or injury, to the employees of the Contractor, of all sums of which the Contractor agrees to pay for the services and all moneys and sums that the Contractor collected or deducted from the wages of employees under any law, contract or agreement for the purpose of providing or paying for the services.

C.5 HOURS OF LABOR

As a condition to Owner's performance hereunder, no person shall be employed to perform Work under the Contract for more than ten (10) hours in any one day or forty (40) hours in any one week, except in cases of necessity, emergency or where public policy absolutely requires it. In such instances, Contractor shall pay the employee at least time and a half pay:

- (a) For all overtime in excess of eight (8) hours a day or forty (40) hours in any one week when the work week is five consecutive Days, Monday through Friday; or
- (b) For all overtime in excess of ten (10) hours a day or forty (40) hours in any one week when the work week is four consecutive Days, Monday through Friday; and
- (c) For all Work performed on Saturday and on any legal holiday specified in ORS 279C.540.

This Section C.5 will not apply to Contractor's Work under the Contract to the extent Contractor is currently a party to a collective bargaining agreement with any labor organization.

This Section C.5 shall not excuse Contractor from completion of the Work within the time required under the Contract.

**SECTION D
CHANGES IN THE WORK**

D.1 CHANGES IN WORK

D.1.1 The terms of the Contract shall not be waived, altered, modified, supplemented or amended in any manner whatsoever, without prior written agreement and then only after any necessary approvals have been obtained. A Change Order is required to modify the Contract, which shall not be effective until its execution by the parties to the Contract and all approvals required by public contracting laws have been obtained.

D.1.2 It is mutually agreed that changes in Plans, quantities, or details of construction may be necessary or desirable during the course of construction. Within the general scope of the Contract, the Owner may at any time, without notice to the sureties and without impairing the Contract, require changes it deems necessary or desirable within the scope of this Project and consistent with this Section D.1. All changes to the Work shall be documented and Change Orders shall be executed under the conditions of the Contract Documents. Such changes may include, but are not limited to:

- (a) Modification of specifications and design.
- (b) Increases or decreases in quantities.
- (c) Increases or decreases to the amount of Work.
- (d) Addition or elimination of any Work item.
- (e) Change in the duration of the Project.

- (f) Acceleration or delay in performance of Work.
- (g) Deductive changes.

Deductive changes are those that reduce the scope of the Work, and shall be made by mutual agreement whenever feasible. In cases of suspension or partial termination under Section J, Owner reserves the right to unilaterally impose a deductive change and to self-perform such Work, for which the provisions of Section B.13 (Owner's Right to Do Work) shall then apply. Adjustments in compensation shall be made under Section D.1.3, in which costs for deductive changes shall be based upon a Direct Costs adjustment together with the related percentage markup specified for profit, Overhead and other indirect costs, unless otherwise agreed to by Owner.

D.1.3 The Owner and Contractor agree that adjustments to or deletions from the Work shall be administered and compensated according to the following:

- (a) Unit Pricing: Unit pricing may be utilized at the Owner's option when unit prices or solicitation alternates were provided that established the cost for adjustments to Work, and a binding obligation exists under the Contract on the parties covering the terms and conditions of the adjustment to Work.
- (b) Fixed Fee: If the Owner elects not to utilize unit pricing, or in the event that unit pricing is not available or appropriate, fixed pricing may be used for adjustments to or deletions from the Work. In fixed pricing, the basis of payments or total price shall be agreed upon in writing between the parties to the Contract, and shall be established before the Work is done whenever feasible. Notwithstanding the foregoing, the mark-ups set forth in Section D.1.3(c) shall be utilized in establishing fixed pricing, and such mark-ups shall not be exceeded. Cost and price data relating to adjustments to or deletions from the Work shall be supplied by Contractor to Owner upon request, but Owner shall be under no obligation to make such requests.
- (c) Time and Material: In the event that unit pricing and fixed pricing are not utilized, then adjustments to or deletions from the Work shall be performed on a cost reimbursement basis for Direct Costs. Such Work shall be compensated on the basis of the actual, reasonable and allowable cost of labor, equipment, and material furnished on the Work performed. The Contractor or Subcontractor who performs the Work shall be allowed to add up to ten percent (10%) markup to the Direct Costs as full compensation for profit, Overhead and other indirect costs for Work performed with the Contractor's or Subcontractor's own agents

Each ascending tier Subcontractor or the Contractor that did not perform the Work, will be allowed to add up to five percent (5%) supplemental markup on the Direct Costs of the Work (but not the above allowable markups) covered by a Change Order. No additional markup shall be permitted for any third tier or greater descending Subcontractor.

Example: \$20,000 of Direct Costs Work performed by a 2nd Tier Subcontractor

	Markup	Allowed Total Fee Plus Markup
General Contractor	5%	\$1,000.00
1 st Tier Sub Contractor	5%	\$1,000.00
2 nd Tier Sub Contractor	10%	\$22,000.00

- (d) Payments made to the Contractor shall be complete compensation for Overhead, profit, and all costs that were incurred by the Contractor or by other agents furnished by the Contractor, including Subcontractors, for adjustments to or deletions from the Work pursuant to a Change Order. Owner may establish a maximum cost for additional Work under this Section D.1.3, which shall not be exceeded for reimbursement without additional written

authorization from Owner in the form of a Change Order. Contractor shall not be required to complete such additional Work without additional authorization.

- D.1.4 Any necessary adjustment of Contract Time that may be required as a result of adjustments to or deletions from the Work must be agreed upon by the parties before the start of the revised Work unless Owner authorizes Contractor to start the revised Work before agreement on Contract Time adjustment.

Contractor shall submit any request for additional compensation (and additional Contract Time if Contractor was authorized to start Work before an adjustment of Contract Time was approved) as soon as possible but no later than thirty (30) Days after receipt of Owner's request for additional Work. If Contractor's request for additional compensation or adjustment of Contract Time is not made within the thirty (30) Day time limit, Contractor's requests pertaining to that additional Work shall be barred. The thirty (30) Day time limit for making requests shall not be extended for any reason, including without limitation Contractor's claimed inability to determine the amount of additional compensation or adjustment of Contract Time, unless an extension is granted in writing by Owner. If the Owner denies Contractor's request for additional compensation or adjustment of Contract Time, Contractor may proceed to file a Claim under Section D.3, Claims Review Process. No other reimbursement, compensation, or payment will be made, except as provided in Section D.1.5 for impact claims.

- D.1.5 If any adjustment to Work under Section D.1.3 causes an increase or decrease in the Contractor's cost of, or the Contract Time required for the performance of any other part of the Work under the Contract, Contractor shall submit a written request to the Owner, setting forth the nature and specific extent of the request, including all time and cost impacts against the Contract as soon as possible, but no later than thirty (30) Days after receipt of Owner's request for adjustments to or deletions from the Work by Contractor.

The thirty (30) Day time limit applies to claims of Subcontractors, suppliers, or manufacturers who may be affected by Owner's request for adjustments to or deletions from the Work and who request additional compensation or an extension of Contract Time to perform; Contractor has responsibility for contacting its Subcontractors, suppliers, or manufacturers within the thirty (30) Day time limit, and including their requests with Contractor's requests. If the request involves Work to be completed by Subcontractors, or materials to be furnished by suppliers or manufacturers, such requests shall be submitted to the Contractor in writing with full analysis and justification for the adjustments to compensation and Contract Time requested. The Contractor shall analyze and evaluate the merits of the requests submitted by Subcontractors, suppliers, and manufacturers to Contractor prior to including those requests and Contractor's analysis and evaluation of those requests with Contractor's requests for adjustments to compensation or Contract Time that Contractor submits to the Owner. Failure of Subcontractors, suppliers, manufacturers or others to submit their requests to Contractor for inclusion with Contractor's requests submitted to Owner within the time period and by the means described in this section shall constitute a waiver of these Subcontractor claims. The Owner will not consider direct requests or claims from Subcontractors, suppliers, manufacturers or others not a party to the Contract. The consideration of such requests and claims under this section does not give any Person, not a party to the Contract the right to bring a claim against Owner, whether in this claims process, in litigation, or in any dispute resolution process.

If the Owner denies the Contractor's request for adjustment to compensation or Contract Time, the Contractor may proceed to file a Claim under Section D.3, Claims Review Process.

- D.1.6 No request or Claim by the Contractor for additional costs or an adjustment of Contract Time shall be allowed if made after receipt of final payment application under the Contract. Final payment application must be made by Contractor within the time required under Section E.6.4.

- D.1.7 It is understood that changes in the Work are inherent in construction of this type. The number of changes, the scope of those changes, and the effect they have on the progress of the original Work cannot be defined at this time. The Contractor agrees that it will work in good faith with Owner to undertake changes, when agreed upon by execution of a Change Order. Each change will be evaluated for extension of Contract Time and increase or decrease in compensation based on its own merit.

D.2 DELAYS

- D.2.1 Contractor shall not be entitled to additional compensation or additional Contract Time for Avoidable Delays.

- D.2.2 In the event of Unavoidable Delays, Contractor may be entitled to the following:

- (a) Contractor may be entitled to additional compensation or additional Contract Time, or both, for Unavoidable Delays described in Section D.2.1.2 (a) and (b).
- (b) Contractor may be entitled to additional Contract Time for Unavoidable Delays described in Section D.2.1.2(c) and (d).

In the event of any requests for additional compensation or additional Contract Time, or both, as applicable, arising under this Section D.2.2 for Unavoidable Delays, other than requests for differing Project Site conditions for which a review process is established under Section A.4.5, Contractor shall submit a written notification of the delay to the Owner within two (2) Days of the occurrence of the cause of the delay. This written notification shall state the cause of the potential delay, the Project components impacted by the delay, and the anticipated additional Contract Time extension or the additional compensation, or both, as applicable, resulting from the delay. Within seven (7) Days after the cause of the delay has been mitigated, or in no case more than thirty (30) Days after the initial written notification, the Contractor shall submit to the Owner, a complete and detailed request for additional compensation or additional Contract Time, or both, as applicable, resulting from the delay. If the Owner denies Contractor's request for additional compensation or adjustment of Contract Time, the Contractor may proceed to file a Claim under Section D.3, Claims Review Process.

If Contractor does not timely submit the notices required under this Section D.2, Contractor's Claim shall be barred.

D.3 CLAIMS REVIEW PROCESS

- D.3.1 All Contractor Claims shall be referred to the Owner for review. Contractor's Claims, including Claims for adjustments to compensation or Contract Time, shall be submitted in writing by Contractor to the Owner within five (5) Days after a denial of Contractor's initial request for an adjustment of Contract terms, payment of money, extension of Contract Time or other relief, provided that such initial request has been submitted in accordance with the requirements and within the time limits established in these County General Conditions. Within thirty (30) Days after the initial Claim, Owner shall receive from Contractor a complete and detailed description of the Claim (the "Detailed Notice") that includes all information required by Section D.3.2. Unless the Claim is made in accordance with these time requirements, it shall be barred.

D.3.2 The Detailed Notice of the Claim shall be submitted in writing by Contractor and shall include all information, records and documentation necessary for the Owner to properly and completely evaluate the claim, including, but not limited to a detailed, factual statement of the basis of the Claim, pertinent dates, Contract provisions which support or allow the Claim, reference to or copies of any documents which support the Claim, the dollar value of the Claim, and the Contract Time adjustment requested for the Claim. If the Claim involves Work to be completed by Subcontractors, the Contractor will analyze and evaluate the merits of the Subcontractor claim prior to forwarding it and that analysis and evaluation to the Owner. The Owner will not consider direct claims from Subcontractors, suppliers, manufacturers, or others not a party to the Contract. Contractor agrees that it will make no agreement, covenant, or assignment, nor will it commit any other act that will permit or assist any Subcontractor, supplier, manufacturer, or other to directly or indirectly make a claim against Owner.

D.3.3 The Owner, through the Architect/Engineer (or other employee or agent assigned by the Owner) will review all Claims and take one or more of the following preliminary actions within ten (10) Days of receipt of the Detailed Notice of a Claim: (1) request additional supporting information from the Contractor; (2) inform the Contractor and Owner in writing of the time required for adequate review and response; (3) reject the Claim in whole or in part and identify the reasons for rejection; (4) recommend approval of all or part of the Claim; (5) arrange a meeting with the Contractor for formal review of the Claim; or (6) propose an alternate resolution.

D.3.4 Once the Engineer or Project Manager determines the Owner is in receipt of a properly submitted claim, the Engineer or Project Manager may arrange a meeting, as agreed by the parties, with the Contractor in order to present the claim for formal review and discussion. A person authorized by the Contractor to execute Change Orders on behalf of the Contractor must be present and attend all claim meetings.

D.3.5 The Owner's decision, through the Architect/Engineer (or other employee or agent assigned by the Owner), shall be final and binding on the Contractor unless appealed by written notice to the Owner within fifteen (15) Days of receipt of the decision. The Contractor must present written documentation supporting the Claim within fifteen (15) Days of the notice of appeal. After receiving the appeal documentation, the Owner, through the appropriate department director, shall review the materials and render a decision within thirty (30) Days after receiving the appeal documents.

D.3.6 If, at any step in the claim decision or review process, the Contractor fails to promptly submit requested information or documentation that the Owner deems necessary to analyze the claim, the Contractor is deemed to have waived its right to further review, and the Claim will not be considered properly filed and preserved.

D.3.7 Both parties agree to exercise their best efforts in good faith to resolve all disputes within sixty (60) Days of the issuance of the appeal in Section D. 3.4 above. If the parties are unable to resolve their issues through mediation or otherwise, either party may seek redress through all available remedies in equity or in law.

D.3.8 Unless otherwise directed by Owner, Contractor shall proceed with the Work while any Claim, or mediation or litigation arising from a Claim, is pending. Regardless of the review period or the final decision of the Owner, the Contractor shall continue to diligently pursue the Work as identified in the Contract Documents. In no case is the Contractor justified or allowed to cease or delay Work, in whole or in part, without a written stop work order from the Owner.

SECTION E PAYMENTS

E.1 SCHEDULE OF VALUES

The Contractor shall submit, by or before the pre-construction conference (as described in Section H.1.3), a schedule of values ("Schedule of Values") for the Contract Work. This schedule shall provide a breakdown of values for the Contract Work and will be the basis for progress payments. The breakdown shall demonstrate reasonable, identifiable, and measurable components of the Work. Unless objected to by the Owner, this schedule shall be used as the basis for reviewing Contractor's applications for payment. If objected to by Owner, Contractor shall revise the schedule of values and resubmit the same for approval of Owner.

E.2 APPLICATIONS FOR PAYMENT

E.2.1 Owner shall make progress payments on the Contract monthly as Work progresses, in accordance with the requirements of this Section E.2 and ORS 279C.570. Applications for payment shall be based upon estimates of Work completed and the Schedule of Values. As a condition precedent to Owner's obligation to pay, all applications for payment shall be approved by the Owner. A progress payment shall not be considered acceptance or approval of any Work or waiver of any defects therein. Owner shall pay to Contractor interest in accordance with ORS 279C.570 for overdue invoices, not including retainage, due the Contractor. Overdue invoices will be those that have not been paid within the earlier of:

- (a) Thirty (30) days after receipt of the invoice; or
- (b) Fifteen (15) days after the payment is approved by the County.

Notwithstanding the foregoing, in instances when an application for payment is filled out incorrectly, or when there is any defect or impropriety in any submitted application or when there is a good faith dispute, Owner shall so notify the Contractor within fifteen (15) Days stating the reason or reasons the application for payment is defective or improper or the reasons for the dispute. A defective or improper application for payment, if corrected by the Contractor within seven (7) Days of being notified by the Owner, shall not cause a payment to be made later than specified in this section unless interest is also paid. Payment of interest will be postponed when payment on the principal is delayed because of disagreement between the Owner and the Contractor.

Owner reserves the right, instead of requiring the Contractor to correct or resubmit a defective or improper application for payment, to reject the defective or improper portion of the application for payment and pay the remainder of the application for such amounts which are correct and proper.

Owner, upon written notice to the Contractor, may elect to make payments to the Contractor only by means of Electronic Funds Transfers ("EFT") through Automated Clearing House ("ACH") payments. If Owner makes this election, the Contractor shall arrange for receipt of the EFT/ACH payments.

E.2.2 Contractor shall submit to the Owner an application for each payment and, if required, receipts or other vouchers showing payments for materials and labor including payments to Subcontractors. Contractor shall include in its application for payment a schedule of the percentages of the various parts of the Work completed, based on the Schedule of Values which shall aggregate to the payment application total, and shall include, on the face of each copy thereof, a certificate in substantially the following form:

"I, the undersigned, hereby certify that the above bill is true and correct, and the payment therefore, has not been received.

Signed: _____
Dated: _____"

E.2.3 Generally, applications for payment will be accepted only for materials that have been installed. Under special conditions, applications for payment for stored materials will be accepted at Owner's sole discretion. Such a payment, if made, will be subject to the following conditions:

- (a) The request for stored material shall be submitted at least thirty (30) Days in advance of the application for payment on which it appears. Applications for payment shall be entertained for major equipment, components or expenditures only.
- (b) The Contractor shall submit applications for payment showing the quantity and cost of the material stored.
- (c) The material shall be stored in a bonded warehouse and Owner shall be granted the right to access the material for the purpose of removal or inspection at any time during the Contract Period.
- (d) The Contractor shall name the Owner as co-insured on the insurance policy covering the full value of the property while in the care and custody of the Contractor until it is installed. A certificate noting this coverage shall be issued to the Owner.
- (e) Payments shall be made for materials and equipment only. The submitted amount in the application for payment shall be reduced by the cost of transportation from the storage site to the Project Site and for the cost of an inspector to verify delivery and condition of the goods at the storage site. The cost of storage and inspection shall be borne solely by the Contractor.
- (f) Within sixty (60) Days of the application for payment, the Contractor shall submit evidence of payment covering the material and/or equipment stored and of payment for the storage site.
- (g) Payment for stored materials and/or equipment shall in no way indicate acceptance of the materials and/or equipment or waive any rights under the Contract for the rejection of the Work or materials and/or equipment not in conformance with the Contract Documents.
- (h) All required documentation shall be submitted with the respective application for payment.

E.2.4 The Owner reserves the right to withhold all or part of a payment, or may nullify in whole or part any payment previously made, to such extent as may be necessary in the Owner's opinion to protect the Owner from loss because of:

- (a) Work that is defective and not remedied, or that has been demonstrated or identified as failing to conform with Applicable Laws or the Contract Documents;
- (b) third party claims filed or evidence reasonably indicating that such claims will likely be filed unless security acceptable to the Owner is provided by the Contractor;
- (c) failure of the Contractor to make payments properly to Subcontractors or for labor, materials or equipment (in which case Owner may issue checks made payable jointly to Contractor and such unpaid persons under this provision, or directly to Subcontractors and suppliers at any level under Section C.3.2);

- (d) reasonable evidence that the Work cannot be completed for the unpaid balance of the Contract Price;
- (e) damage to the Work, Owner or Owner's agent;
- (f) reasonable evidence that the Work will not be completed within the Contract Time required by the Contract, and that the unpaid balance would not be adequate to cover actual or liquidated damages for the anticipated delay;
- (g) failure to carry out the Work in accordance with the Contract Documents; or
- (h) assessment of liquidated damages, when withholding is made for offset purposes.

E.2.5 Subject to the provisions of the Contract Documents, the amount of each progress payment shall be computed as follows:

- (a) Take that portion of the Contract Price properly allocable to completed Work as determined by multiplying the percentage completion of each portion of the Work by the share of the total Contract Price allocated to that portion of the Work in the Schedule of Values, less retainage as provided in Section E.5. Pending final determination of cost to the Owner of changes in the Work, no amounts for changes in the Work can be included in applications for payment until the Contract Price has been adjusted by a Change Order;
- (b) Add that portion of the Contract Price properly allocable to materials and equipment delivered and suitably stored at the Project Site for subsequent incorporation in the completed construction (or, if approved in advance by the Owner pursuant to Section E.2.3, suitably stored off the Project Site at a location agreed upon in writing), less retainage as provided in Section E.5;
- (c) Subtract the aggregate of previous payments made by the Owner; and
- (d) Subtract any amounts for which the Owner has withheld or nullified payment as provided in the Contract Documents.

E.2.6 Contractor's applications for payment shall not include requests for payment for portions of the Work for which the Contractor does not intend to pay to a Subcontractor or material supplier.

E.2.7 The Contractor warrants to Owner that title to all Work covered by an application for payment will pass to the Owner no later than the time of payment. The Contractor further warrants that upon submittal of an application for payment all Work for which payments are received from the Owner shall be free and clear of liens, claims, security interests or encumbrances in favor of the Contractor, Subcontractors, material suppliers, or other persons or entities making a claim by reason of having provided financing, labor, materials and equipment relating to the Work.

E.2.8 If Contractor disputes any determination by Owner with regard to any application for payment, Contractor nevertheless shall continue to expeditiously perform the Work. No payment made hereunder shall be or be construed to be final acceptance or approval of that portion of the Work to which such partial payment relates or shall relieve Contractor of any of its obligations hereunder.

E.3 PAYROLL CERTIFICATION REQUIREMENT

Owner's receipt of payroll certification pursuant to Section C.2 of the Contract shall be a condition precedent to Owner's obligation to pay any progress payments or final payment otherwise due.

E.4 DUAL PAYMENT SOURCES

Contractor shall not be compensated for Work performed under the Contract from any state agency other than the agency that is a party to the Contract.

E.5 RETAINAGE

E.5.1 Retainage shall be withheld and released in accordance with the requirements set forth in Local Contract Review Board Rules or the applicable County standard.

E.5.1.1 Owner may reserve as retainage from any progress payment an amount not to exceed five percent of the payment. As Work progresses, Owner may reduce the amount of retainage on or may eliminate retainage on any remaining monthly Contract payments after fifty (50) percent of the Work under the Contract is completed if, in the Owner's discretion, such Work is progressing satisfactorily. Elimination or reduction of retainage shall be allowed only upon written application by the Contractor, which application shall include written approval of Contractor's surety; except that when the Work is ninety-seven and a half percent (97.5%) completed in Owner's estimation, the Owner may, at its discretion and without application by the Contractor, reduce the retained amount to hundred (100) percent of the value of the Work remaining to be done. Upon receipt of written application by the Contractor, Owner shall respond in writing within a reasonable time.

E.5.1.2 If retainage is withheld, unless the Contractor requests and the Owner accepts a form of retainage described in options (a) or (b) below, the Owner (except as otherwise provided below for a contract of \$500,000 or less), will deposit the retainage in an interest-bearing escrow account as required by ORS 279C.570(2). The Contractor shall execute such documentation and instructions respecting the interest-bearing escrow account as the Owner may require to protect its interests, including but not limited to a provision that no funds may be paid from the account to anyone without the Owner's advance written authorization. For a Contract over \$500,000, if the Contractor requests that the Owner deposit the retainage in an interest-bearing account under ORS 279C.560(5), the Owner will use an interest-bearing escrow account as stated above. For a Contract of \$500,000 or less, if the Contractor requests that the Owner deposit the retainage in an interest-bearing account under ORS 279C.560(5), the Owner will use an interest-bearing account (in a bank, savings bank, trust company or savings association) as provided under ORS 279C.450(5).

In accordance with the provisions of ORS 279C.560, Local Contract Review Board Rules, or the applicable County standard, unless the Owner finds in writing that accepting bonds, securities or other instruments described in option (a) below or a security bond described in option (b) below poses an extraordinary risk that is not typically associated with the bond, security or instrument, the Owner will approve the Contractor's written request:

- a. to be paid amounts which would otherwise have been retained from progress payments where Contractor has deposited acceptable bonds, securities or other instruments of equal value with Owner or in a custodial account or other mutually-agreed account satisfactory to Owner, with an approved bank or trust company to be held in lieu of the cash retainage for the benefit of Owner. Interest or earnings on the bonds, securities or other instruments shall accrue to the Contractor. The Contractor shall execute and provide such documentation and instructions respecting the bonds, securities and other instruments as the Owner may require to protect its interests. To be permissible, the bonds, securities and other instruments must be of a character approved by Owner; or

- b. that the Contractor be allowed, with the approval of the Owner, Owner allow Contractor to deposit a surety bond for the benefit of Owner, in a form acceptable to Owner, in lieu of all or a portion of funds retained, or to be retained. Such bond and any proceeds therefrom shall be made subject to all claims and liens in the manner and priority as set forth for retainage under ORS 279C.550 to ORS 279C.625.

When the Owner has accepted the Contractor's election of option (a) or (b), Owner may recover from Contractor any additional costs incurred through such election by reducing Contractor's final payment. Where the Owner has agreed to Contractor's request for option (b), Contractor shall accept like bonds from Subcontractors and suppliers on the Project from which Contractor has required retainages.

E. 5.1.3 The retainage held by Owner shall be included in and paid to the Contractor as part of the final payment of the Contract Price. The Owner shall pay to Contractor interest at the rate of two thirds of one percent per month on the final payment due Contractor, interest to commence forty-five (45) Days after the date which Owner receives Contractor's final approved application for payment and Work under the Contract has been completed and accepted and to run until the date when final payment is tendered to Contractor. The Contractor shall notify Owner in writing when the Contractor considers the Work complete and deliver to Owner its final application for payment and Owner shall, within fifteen (15) Days after receiving the written notice and the application for payment, either accept the Work or notify the Contractor of Work yet to be performed on the Contract. If Owner does not within the time allowed notify the Contractor of Work yet to be performed to fulfill contractual obligations, the interest provided by this subsection shall commence to run forty-five (45) Days after the end of the fifteen (15) Day period.

E.5.1.4 Owner will reduce the amount of the retainage if the Contractor notifies the Owner that the Contractor has deposited in an escrow account with a bank or trust company, in a manner authorized by the Owner, bonds and securities of equal value of a kind approved by the Owner and such bonds and securities have in fact been deposited.

E.5.1.5 Contractor agrees that if Contractor elects to reserve a retainage from any progress payment due to any Subcontractor or supplier, such retainage shall not exceed five percent of the payment, and such retainage withheld from Subcontractors and suppliers shall be subject to the same terms and conditions stated in Subsection E.5 as apply to Owner's retainage from any progress payment due to Contractor.

E.5.1.6 The Contractor shall comply with all applicable legal requirements for withholding and releasing retainage and for prompt payments, including but not limited to those in ORS Chapters 279C and 701, and 49 CFR 26.29.

E.6 FINAL PAYMENT

E.6.1 Upon completion of all the Work under the Contract, the Contractor shall notify the Owner, in writing, that Contractor has completed Contractor's obligations under the Contract and shall prepare its application requesting final payment. The amount of final payment will be the difference between the total amount due the Contractor pursuant to the Contract Documents and the sum of all payments previously made. Upon receipt of such notice and application for payment, the Owner will inspect the Work, and, if acceptable, submit to Contractor a recommendation as to acceptance of the completed Work and the final estimate of the amount due the Contractor. If the Work is not acceptable, Owner will notify Contractor within fifteen (15) Days of Contractor's request for final payment. Upon approval of this final application for payment by the Owner and compliance by the Contractor with

provisions in Section K, and Contractor's satisfaction of other provisions of the Contract Documents as may be applicable, the Owner shall pay to the Contractor all monies due under the provisions of these Contract Documents.

- E.6.2 Neither final payment nor any remaining retained percentage shall become due until the Contractor submits to the Owner (1) a certificate evidencing that insurance required by the Contract Documents to remain in force after final payment is currently in effect and will not be canceled or allowed to expire until at least thirty (30) Days' prior written notice has been given to the Owner, (2) a written statement that the Contractor knows of no substantial reason that the insurance will not be renewable to cover the period required by the Contract Documents, (3) consent of surety, if any, to final payment and (4), if required by the Owner, other data establishing payment or satisfaction of obligations, such as receipts, releases and waivers of liens, claims, security interests or encumbrances arising out of the Contract, to the extent and in such form as may be designated by the Owner. If a Subcontractor refuses to furnish a release or waiver required by the Owner, the Contractor may furnish a bond satisfactory to the Owner to indemnify the Owner against such lien. If such lien remains unsatisfied after payments are made, the Contractor shall refund to the Owner all money that the Owner may be compelled to pay in discharging such lien.
- E.6.3 Acceptance of final payment by the Contractor, a Subcontractor or material supplier shall constitute a waiver of claims by that payee except those previously made in writing and identified by that payee as unsettled at the time of final application for payment.
- E.6.4 Contractor agrees to submit its final payment application within ninety (90) Days after Substantial Completion, unless written extension is granted by Owner. Contractor shall not delay final payment application for any reason, including without limitation nonpayment of Subcontractors, suppliers, manufacturers or others not a party to the Contract, or lack of resolution of a dispute with Owner or any other person of matters arising out of or relating to the Contract. If Contractor fails to submit its final payment application within ninety (90) Days after Substantial Completion, and Contractor has not obtained written extension by Owner, all requests or Claims for additional costs or an extension of Contract Time shall be barred.

SECTION F PROJECT SITE CONDITIONS

F.1 USE OF PREMISES

Contractor shall confine equipment, storage of materials and operation of Work to the limits indicated by Contract Documents, Applicable Laws, permits or directions of the Owner. Contractor shall follow the Owner's instructions regarding use of premises, if any.

F.2 PROTECTION OF WORKERS, PROPERTY AND THE PUBLIC

- F.2.1 Contractor shall maintain continuous and adequate protection of all of the Work from damage and shall protect the Owner, workers and property from injury or loss arising in connection with the Contract. Contractor shall remedy acceptably to the Owner any damage, injury, or loss, except such as may be directly due to errors in the Contract Documents or caused by authorized representatives or personnel of the Owner. Contractor shall adequately protect adjacent property as provided by law and the Contract Documents.
- F.2.2 Contractor shall take all necessary precautions for the safety of all personnel on the Project Site or otherwise engaged in the undertaking of the Work and shall comply with the Contract Documents, best practices and all applicable provisions of federal, state and municipal safety laws and building codes to prevent

accidents or injury to persons on, about or adjacent to the premises where the Work is being performed. Contractor shall erect and properly maintain at all times, as required by the conditions and progress of the Work, all necessary safeguards for protection of workers and the public against any hazards created by construction. Contractor shall designate a responsible employee or associate on the Project Site, whose duty shall be the prevention of accidents. The name and position of the person designated shall be reported to the Owner. The Owner has no responsibility for Project Site safety. Project Site safety shall be the responsibility of the Contractor.

- F.2.3 Contractor shall not enter upon private property without first obtaining permission from the property owner or its duly authorized representative. Contractor shall be responsible for the preservation of all public and private property along and adjacent to the Work contemplated under the Contract and shall use every precaution necessary to prevent damage thereto. In the event the Contractor damages any property, the Contractor shall at once notify the property owner and make, or arrange to make, full restitution. Contractor shall, immediately and in writing, report to the Owner, all pertinent facts relating to such property damage and the ultimate disposition of the claim for damage.
- F.2.4 Contractor shall be responsible for protection of adjacent work areas including impacts brought about by activities, equipment, labor, utilities, vehicles and materials on the Project Site.
- F.2.5 Contractor shall at all times direct its activities in such a manner as to minimize adverse effects on the environment. Handling of all materials shall be conducted so no release will occur that may pollute or become hazardous.
- F.2.6 In an emergency affecting the safety of life or limb or of the Work or of adjoining property, the Contractor, without special instruction or authorization from the Owner, shall act reasonably to prevent threatened loss or injury, and shall so act, without appeal, if instructed by the Owner. Any compensation claimed by the Contractor on account of emergency work shall be determined in accordance with section D.
- F.2.7 Contractor shall comply with all Owner safety rules and regulations, if applicable. Prior to commencement of any Work, Contractor and Subcontractors shall be required to complete an Owner Contractor Safety Orientation and submit all Owner required safety plans.
- F.2.8 Contractor shall demonstrate that an employee drug testing program is in place.

F.3 CUTTING AND PATCHING

- F.3.1 If applicable, Contractor shall be responsible for coordinating all cutting, fitting, or patching of the Work to make its several parts come together properly and fit to receive or be received by work of other contractors or Subcontractors shown upon, or reasonably implied by, the Contract Documents.
- F.3.2 If applicable, Contractor shall be responsible for restoring all cut, fitted, or patched surfaces to an original condition; provided, however, that if a different condition is specified in the Contract Documents, then Contractor shall be responsible for restoring such surfaces to the condition specified in the Contract Documents.

F.4 CLEANING UP

From time to time as may be prudent or ordered by the Owner and, in any event, immediately after completion of the Work, the Contractor shall, at its own expense, clean up and remove all refuse and unused materials of any kind resulting from the Work. If Contractor fails to do so within twenty-four (24) hours after notification by the Owner the work may be

done by others and the cost charged to the Contractor and deducted from payment due the Contractor.

F.5 ENVIRONMENTAL CONTAMINATION

F.5.1 Contractor shall be held responsible for and shall indemnify, defend (with counsel of Owner's choice), and hold harmless Owner from and against any costs, expenses, damages, claims, and causes of action, or any of them, resulting from all spills, releases, discharges, leaks and disposal of environmental pollution, including storage, transportation, and handling during the performance of the Work or Contractor's obligations under the Contract which occur as a result of, or are contributed by, the negligence or actions of Contractor or its personnel, agents, or Subcontractors or any failure to perform in accordance with the Contract Documents (except to the extent otherwise void under ORS 30.140). Nothing in this section F.5.1 shall limit Contractor's responsibility for obtaining insurance coverages required under Section G.3 of the Contract, and Contractor shall take no action that would void or impair such coverages.

F.5.1.1 Contractor agrees to promptly dispose of such spills, releases, discharge or leaks to the satisfaction of Owner and regulatory agencies having jurisdiction in a manner that complies with Applicable Laws. Cleanup shall be at no cost to the Owner and shall be performed by properly qualified and, if applicable, licensed personnel.

F.5.1.2 Unless otherwise approved in the Solicitation Document, Contractor shall obtain the Owner's written consent prior to bringing onto the Project Site any (i) environmental pollutants or (ii) hazardous substances or materials, as the same or reasonably similar terms are used in any Applicable Laws. In any event, Contractor shall provide prior written notice to Owner when hazardous materials are brought on to the Project Site. The Contractor, at all times, shall:

- (a) properly handle, use and dispose of all environmental pollutants and hazardous substances or materials on the Project Site, in accordance with all Applicable Laws;
- (b) be responsible for any and all spills, releases, discharges, or leaks of (or from) environmental pollutants or hazardous substances or materials which Contractor has brought onto the Project Site; and
- (c) promptly clean up and remediate, without cost to the Owner, such spills, releases, discharges, or leaks to the Owner's satisfaction and in compliance with all Applicable Laws.

F.5.2 Contractor shall report all reportable quantity releases, as such releases are defined in Applicable Laws. Upon discovery, regardless of quantity, Contractor must verbally report all releases to the Owner in a prompt manner. A written follow-up report shall be submitted to Owner within 48 hours of the telephonic report. Such written report shall contain, as a minimum:

- (a) Description of items released (identity, quantity, manifest numbers, and any and all other documentation required by law).
- (b) Whether amount of items released is EPA/DEQ reportable, and, if so, when reported.
- (c) Exact time and location of release, including a description of the area involved.
- (d) Containment procedures initiated.

(e) Summary of communications about the release between Contractor and State, local or federal officials other than Owner. Any communication to the press will be done by Owner and Contractor will defer to Owner.

(f) Description of cleanup procedures employed or to be employed at the Project Site, including disposal location of spill residue.

(g) Personal injuries, if any, resulting from, or aggravated by, the release.

F.6 ENVIRONMENTAL CLEAN-UP

F.6.1 Unless disposition of environmental pollution is specifically a part of the Contract, or was caused by the Contractor (reference F.5 Environmental Contamination), Contractor shall immediately notify Owner of any hazardous substance(s) which Contractor discovers or encounters during performance of the Work required by the Contract. "Hazardous substance(s)" means any hazardous, toxic and radioactive materials and those substances defined as "hazardous substances," "hazardous materials," "hazardous wastes," "toxic substances," or other similar designations in any federal, state, or local law, regulation, or ordinance, including without limitation asbestos, polychlorinated biphenyl ("PCB"), or petroleum, and any substances, materials or wastes regulated by 40 CFR, Part 261 and defined as hazardous in 40 CFR S 261.3. In addition to notifying Owner of any hazardous substance(s) discovered or encountered, Contractor shall immediately cease working in any particular area of the Project where a hazardous substance(s) has been discovered or encountered if continued work in such area would present a risk or danger to the health or wellbeing of Contractor's or any Subcontractor's work force, property or the environment.

F.6.2 Upon being notified by Contractor of the presence of hazardous substance(s) on the Project Site, not brought on to the Project Site by Contractor, Owner shall arrange for the proper disposition of such hazardous substance(s).

F.7 DEMOLITION

F.7.1 For demolition tasks, if any, the Contractor shall salvage or recycle construction and demolition debris, if feasible and cost-effective.

SECTION G INDEMNITY, BONDING, AND INSURANCE

G.1 RESPONSIBILITY FOR DAMAGES / INDEMNITY

G.1.1 Contractor shall be responsible for all damage to property, injury to persons, and loss, expense, inconvenience, and delay that may be caused by, or result from, the carrying out of the Work to be done under the Contract, or from any act, omission or neglect of the Contractor, its Subcontractors, employees, guests, visitors, invitees and agents.

G.1.2 To the fullest extent permitted by law, Contractor shall indemnify, defend (with counsel approved by Owner) and hold harmless the Owner and its elected officials, officers, directors, agents, and employees (collectively "Indemnitees") from and against all liabilities, damages, losses, claims, expenses, demands and actions of any nature whatsoever which arise out of, result from or are related to: (a) any damage, injury, loss, expense, inconvenience or delay described in this Section G.1; (b) any accident or occurrence which happens or is alleged to have happened in or about the Project Site or any place where the Work is being performed, or in the vicinity of either, at any time prior to the time the Work is fully completed in all respects; (c) any failure of the Contractor to

observe or perform any duty or obligation under the Contract Documents which is to be observed or performed by the Contractor, or any breach of any agreement, representation or warranty of the Contractor contained in the Contract Documents or in any subcontract; (d) the negligent acts or omissions of the Contractor, a Subcontractor or anyone directly or indirectly employed by them or any one of them or anyone for whose acts they may be liable, regardless of whether or not such claim, damage, loss or expense is caused in part by a party indemnified hereunder (except to the extent otherwise void under ORS 30.140); and (e) any lien filed upon the Project or bond claim in connection with the Work. Such obligation shall not be construed to negate, abridge, or reduce other rights or obligations of indemnity which would otherwise exist as to a party or person described in this Section G.1.2.

G.1.3 In claims against any person or entity indemnified under Section G.1.2 by an employee of the Contractor, a Subcontractor, anyone directly or indirectly employed by them or anyone for whose acts they may be liable, the indemnification obligation under Section G.1.2 shall not be limited on amount or type of damages, compensation or benefits payable by or for the Contractor or a Subcontractor under workers' compensation acts, disability benefit acts or other employee benefit acts.

G.2 PERFORMANCE AND PAYMENT SECURITY; PUBLIC WORKS BOND

G.2.1 When the Contract Price is \$50,000 or more, the Contractor shall furnish and maintain in effect at all times during the Contract Period a performance bond in a sum equal to the Contract Price and a separate payment bond also in a sum equal to the Contract Price. Contractor shall furnish such bonds even if the Contract Price is less than the above thresholds if otherwise required by the Contract Documents.

G.2.2 Bond forms furnished by the Owner and notarized by Contractor's surety company authorized to do business in Oregon are the only acceptable forms of performance and payment security, unless otherwise specified in the Contract Documents.

G.2.3 Before execution of the Contract, the Contractor shall file with the Construction Contractors Board, and maintain in full force and effect, the separate public works bond required by Oregon Revised Statutes, Chapter 279C.830 and 279C.836, unless otherwise exempt under those provisions. The Contractor shall also include in every subcontract a provision requiring the Subcontractor to have a public works bond filed with the Construction Contractors Board before starting Work, unless otherwise exempt, and shall verify that the Subcontractor has filed a public works bond before permitting any Subcontractor to start Work.

G.3 INSURANCE

G.3.1 Primary Coverage: Insurance carried by Contractor under the Contract shall be the primary coverage. The coverages indicated are minimums unless otherwise specified in the Contract Documents.

G.3.2 Workers' Compensation: All employers, including Contractor, that employ subject workers who work under the Contract in the State of Oregon shall comply with ORS 656.017 and provide the required Workers' Compensation coverage, unless such employers are exempt under ORS 656.126. This shall include Employer's Liability Insurance with coverage limits of not less than the minimum amount required by statute for each accident. Contractors who perform the Work without the assistance or labor of any employee need not obtain such coverage if the Contractor certifies so in writing. Contractor shall ensure that each of its Subcontractors complies with these requirements. The Contractor shall require proof of such Workers' Compensation coverage by receiving and keeping on file a certificate of insurance from each

Subcontractor or anyone else directly employed by either the Contractor or its Subcontractors.

G.3.3 Builder's Risk Insurance:

G.3.3.1 Builder's Risk: During the term of the Contract, for new construction the Contractor shall obtain and keep in effect Builder's Risk insurance on an all risk forms, including earthquake and flood, for an amount equal to the full amount of the Contract, plus any changes in values due to modifications, Change Orders and loss of materials added. Such Builder's Risk shall include, in addition to earthquake and flood, theft, vandalism, mischief, collapse, transit, debris removal, and architect's fees "soft costs" associated with delay of Project due to insured peril. Any deductible shall not exceed \$50,000 for each loss, except the earthquake and flood deductible which shall not exceed 2 percent of each loss or \$50,000, whichever is greater. The deductible shall be paid by Contractor. The policy will include as loss payees Owner, the Contractor and its Subcontractors as their interests may appear.

G.3.3.2 Builder's Risk Installation Floater: For Work other than new construction, Contractor shall obtain and keep in effect during the term of the Contract, a Builder's Risk Installation Floater for coverage of the Contractor's labor, materials and equipment to be used for completion of the Work performed under the Contract. The minimum amount of coverage to be carried shall be equal to the full amount of the Contract. The policy will include as loss payees Owner, the Contractor and its Subcontractors as their interests may appear. Owner may waive this requirement at its sole and absolute discretion.

G.3.3.3 Such insurance shall be maintained until Owner has occupied the facility.

G.3.3.4 A loss insured under the Builder's Risk insurance shall be adjusted by the Owner and made payable to the Owner as loss payee. The Contractor shall pay Subcontractors their just shares of insurance proceeds received by the Contractor, and by appropriate agreements, written where legally required for validity, shall require Subcontractors to make payments to their Sub-subcontractors in similar manner. The Owner shall have power to adjust and settle a loss with insurers.

G.3.4 General Liability Insurance:

G.3.4.1 Commercial General Liability: Upon execution of a Contract, Contractor shall obtain, and keep in effect at Contractor's expense for the term of the Contract, Commercial General Liability Insurance ("CGL") covering bodily injury and property damage in the amount of not less than \$1,000,000 per claim and \$2,000,000 per occurrence in a form satisfactory to Owner. This insurance shall include personal injury liability, products and completed operations, and contractual liability coverage for the indemnities provided under the Contract (to the extent contractual liability coverage for the indemnity is available in the marketplace), and shall be issued on an occurrence basis written on ISO Form GC 00 01 (12 04 or later) or an equivalent form approved in advance by Owner. The CGL shall provide separation of insured language. The policy or policies obtained by Contractor for purposes of fulfilling the requirements of this section shall be primary insurance with respect to the Owner. Any insurance or self-insurance maintained by the County shall be excess and shall not contribute to it.

G.3.4.2 Automobile Liability: Contractor shall obtain, at Contractor's expense, and keep in effect during the term of the Contract, Automobile Liability Insurance covering owned, and/or hired vehicles, as applicable. The coverage may be written in combination with the Commercial General Liability Insurance. Contractor shall provide proof of insurance of not less than \$1,000,000 per claim and \$2,000,000 per occurrence. Contractor

and its Subcontractors shall be responsible for ensuring that all non-owned vehicles maintain adequate Automobile Liability insurance while on Project Site.

- G.3.4.3 Owner may adjust the insurance amounts required in Section G.3.4.1 and G.3.4.2 based upon institution specific risk assessments through the issuance of Supplemental General Conditions and a Contract.
- G.3.4.4 To the extent that the Contract Documents require the Contractor to provide professional design services, design-build, or certifications related to systems, materials, or equipment, the Contractor shall (1) purchase and maintain professional liability/errors-and-omissions insurance with limits of not less than \$1,000,000 for each claim and \$2,000,000 general annual aggregate and (2) cause those Subcontractors (of any tier) who are providing professional design services including any design-build services to procure and maintain professional liability/errors-and-omissions insurance with limits of not less than \$1,000,000 for each claim and \$2,000,000 general annual aggregate. This policy shall be for the protection of the Owner, its elected officials, officers, agents and employees against liability for damages because of personal injury, bodily injury, death, or damage to property, including loss of use thereof, and damages because of negligent acts, errors and omissions in any way related to the Contract. The Owner, at its option, may require a complete copy of the above policy.
- G.3.4.5 "Tail" Coverage: If any of the required liability insurance is arranged on a "claims made" basis, "tail" coverage will be required at the completion of the Contract for a duration of 36 months or the maximum time period available in the marketplace if less than 36 months. Contractor shall furnish certification of "tail" coverage as described or continuous "claims made" liability coverage for 36 months following Final Completion. Continuous "claims made" coverage will be acceptable in lieu of "tail" coverage, provided its retroactive date is on or before the effective date of the Contract. Owner's receipt of the policy endorsement evidencing such coverage shall be a condition precedent to Owner's obligation to make final payment and to Owner's final acceptance of Work or services and related warranty (if any).
- G.3.4.6 Umbrella Liability (if required by Owner through issuance of Supplemental General Conditions): Contractor shall obtain, at Contractor's expense, and keep in effect during the term of the Contract, Umbrella liability Insurance over and above the general liability, automobile liability and workers' compensation coverage if required by Owner in specified limits at time of requirement.
- G.3.4.7 Pollution Liability may be required by Owner through issuance of Supplemental General Conditions.
- G.3.5 Additional Insured: The general liability insurance coverage, automobile liability, umbrella, and pollution liability if required, shall include the Owner as additional insureds but only with respect to the Contractor's activities to be performed under the Contract. The additional-insured endorsement for CGL insurance must be written on ISO Form CG 20 10 (10 01) and CG 20 37 (10 01), or their equivalent, but shall not use either of the following forms: CG 20 10 (10 93) or CG 20 10 (03 94). Proof of insurance must include a copy of the endorsement showing "Clackamas County, its elected officials, agents, officers, and employees" as scheduled insureds.

If Contractor cannot obtain an insurer to name the Owner as additional insureds, Contractor shall obtain at Contractor's expense, and keep in effect during the term of the Contract, Owners and Contractors Protective Liability Insurance, naming the Owner as additional insureds with not less than a \$2,000,000

limit per occurrence. This policy must be kept in effect for 36 months following Final Completion. As evidence of coverage, Contractor shall furnish the actual policy to Owner prior to execution of the Contract.

- G.3.6 Notice of Cancellation or Change: If the Contractor receives a non-renewal or cancellation notice from an insurance carrier affording coverage required herein, or receives notice that coverage no longer complies with the insurance requirements herein, Contractor agrees to notify Owner by fax within five (5) business days with a copy of the non-renewal or cancellation notice, or written specifics as to which coverage is no longer in compliance. When notified by Owner, the Contractor agrees to stop Work pursuant to the Contract at Contractor's expense, unless all required insurance remain in effect. Any failure to comply with the reporting provisions of this insurance, except for the potential exhaustion of aggregate limits, shall not affect the coverages provided to the Owner and its institutions, divisions, officers, and employees.

Owner shall have the right, but not the obligation, of prohibiting Contractor from entering the Project Site until a new certificate(s) of insurance is provided to Owner evidencing the replacement coverage. The Contractor agrees that Owner reserves the right to withhold payment to Contractor until evidence of reinstated or replacement coverage is provided to Owner.

- G.3.7 Certificate(s) of Insurance/Insurance Carrier Qualification: As evidence of the insurance coverage required by the Contract, the Contractor shall furnish certificate(s) of insurance to the Owner prior to execution of the Contract. The certificate(s) will specify all of the parties who are additional insureds or loss payees for the Contract. A renewal certificate shall be sent to Owner at least 10 days prior to coverage expiration. Insurance coverage required under the Contract shall be obtained from insurance companies or entities acceptable to the Owner and that are eligible to provide such insurance under Oregon law. Eligible insurers include admitted insurers that have been issued a certificate of authority from the Oregon Department of Consumer and Business Services authorizing them to conduct an insurance business and issue policies of insurance in the state of Oregon, and certain non-admitted surplus lines insurers that satisfy the requirements of applicable Oregon law and which are subject to approval by the Owner. The Contractor shall be financially responsible for all deductibles, self-insured retentions and/or self-insurance included hereunder. Any deductible, self-insured retention and/or self-insurance in excess of \$50,000 shall be subject to approval by the Owner in writing and shall be a condition precedent to the effectiveness of any Contract.

SECTION H SCHEDULE OF WORK

H.1 CONTRACT PERIOD

- H.1.1 Time is of the essence. The Contractor shall at all times carry on the Work diligently, without delay and punctually fulfill all requirements herein.
- H.1.2 Notice to Proceed. Unless otherwise directed in the Contract Documents, Contractor shall commence Work on the Project Site within fifteen (15) Days of the Notice to Proceed. Notwithstanding the Notice to Proceed, Contractor shall not be authorized to proceed with the Work until all initial Contract requirements, including the Contract, performance bond and payment bond, and certificates of insurance, have been fully executed and submitted in a form acceptable to Owner.
- H.1.3 Unless otherwise not required in the Construction Documents, Contractor shall participate in a pre-construction conference with the Owner's representative and designated design team. The

purpose of this pre-construction conference is to review the Contractor's proposed Schedule of Values and to review any other Project logistics to be coordinated between the parties.

H.1.4 Unless specifically extended by a Change Order, all Work shall be complete by the date contained in the Contract Documents. The Owner shall have the right to accelerate the completion date of the Work, which may require the use of overtime. Such accelerated Work schedule shall be an acceleration in performance of Work under Section D.1.2(f) and shall be subject to the provisions of Section D.1.

H.1.5 The Owner shall not waive any rights under the Contract by permitting the Contractor to continue or complete in whole or in part the Work after the date described in Section H.1.2 above.

H.2 SCHEDULE

H.2.1 Contractor shall provide, by or before the pre-construction conference, the initial as-planned schedule for review and acceptance by the Owner. The submitted schedule must illustrate Work by Project components, labor trades, and long lead items broken down by building and/or floor where applicable. If Owner shall so elect, Contractor shall provide the schedule in CPM format showing the graphical network of planned activities, including i) a reasonably detailed list of all activities required to complete the Work; ii) the time and duration that each activity will take to completion; and iii) the dependencies between the activities. Schedules lacking adequate detail, or unreasonably detailed, will be rejected. The schedule shall include the following: Notice to Proceed or the date the Work commences, if no Notice to Proceed is issued by Owner, Substantial Completion, and Final Completion. Schedules shall be updated monthly, unless otherwise required by the Contract Documents, and submitted with the monthly application for payment. Acceptance of the Schedule by the Owner does not constitute agreement by the Owner as to the Contractor's sequencing, means, methods, or durations. Any positive difference between the Contractor's scheduled completion and the Contract completion date is float owned by the Owner. Owner reserves the right to negotiate the float if it is deemed to be in Owner's best interest to do so. In no case shall the Contractor make a claim for delays if the Work is completed within the Contract Time but after Contractor's scheduled completion.

H.2.2 All Work shall be completed during normal weekdays (Monday through Friday) between the hours of 7:00 a.m. and 5:00 p.m. unless otherwise specified in the Contract Documents. Unless otherwise specified in the Contract Documents, no Work shall be performed during the following holidays:

- New Year's Day
- Martin Luther King Day
- Memorial Day
- Independence Day
- Labor Day
- Veterans Day
- Thanksgiving Day
- Christmas Day
- President's Day

When a holiday falls on a Sunday, the following Monday shall be recognized as a legal holiday. When a holiday falls on Saturday, the preceding Friday shall be recognized as a legal holiday.

H.3 PARTIAL OCCUPANCY OR USE

The Owner may occupy or use any completed or partially completed portion of the Work at any stage, provided such occupancy or use is consented to by public authorities having

jurisdiction over the Work. Such partial occupancy or use may commence whether or not the portion is substantially complete, provided the Owner and Contractor have reasonably accepted in writing the responsibilities assigned to each of them. Approval by the Contractor to partial occupancy or use shall not be unreasonably withheld. Immediately prior to such partial occupancy or use, the Owner and Contractor shall jointly inspect the area to be occupied or portion of the Work to be used in order to determine and record the condition of the Work. Partial occupancy or use of a portion or portions of the Work shall not constitute acceptance of Work not complying with the requirements of the Contract Documents.

SECTION I CORRECTION OF WORK

I.1 CORRECTION OF WORK BEFORE FINAL PAYMENT

The Contractor warrants to the Owner that materials and equipment furnished under the Contract will be of good quality and new unless otherwise required or permitted by the Contract Documents, that the Work will be free from defects, and that the Work will conform to the requirements of the Contract Documents. Work failing to conform to these requirements shall be deemed defective. Contractor shall promptly remove from the premises and replace all defective materials and equipment as determined by the Owner, whether incorporated in the Work or not. Removal and replacement shall be without loss or expense to the Owner, and Contractor shall bear the cost of repairing all Work destroyed or damaged by such removal or replacement. Contractor shall be allowed a period of no longer than thirty (30) Days after Substantial Completion for completion of defective (Punch List) work. At the end of the thirty-day period, or earlier if requested by the Contractor, Owner shall arrange for inspection of the Work by the Architect/Engineer. Should the work not be complete, and all corrections made, the costs for all subsequent reinspections shall be borne by the Contractor. If Contractor fails to complete the Punch List work within the thirty (30) Day period, Owner may perform such work and Contractor shall reimburse Owner all costs of the same within ten (10) Days after demand without affecting Contractor's obligations.

I.2 WARRANTY WORK

I.2.1 Neither the final certificate of payment nor any provision of the Contract Documents shall relieve the Contractor from responsibility for Defective Work and, unless a longer period is specified, Contractor shall correct all defects that appear in the Work within a period of one year from the date of issuance of the written notice of Substantial Completion by the Owner except for latent defects which will be remedied by the Contractor at any time they become apparent. The Owner shall give Contractor notice of defects with reasonable promptness. Contractor shall perform such warranty work within a reasonable time after Owner's demand and at Contractor's sole expense. If Contractor fails to complete the warranty work within such period as Owner determines reasonable, or at any time in the event of warranty work consisting of emergency repairs, Owner may perform such work and Contractor shall reimburse Owner all costs of the same within ten (10) Days after demand, without affecting Contractor's obligations. The Contractor shall perform the warranty Work by correcting defects within twenty-four (24) hours of notification by Owner, unless otherwise specified in the Contract Documents. Should the Contractor fail to respond within the specified response time, the Owner may, at its option, complete the necessary repairs using another contractor or its agents. If Owner completes the repairs using Owner's agent, Contractor shall pay Owner at the rate of one and one-half (1½) times the standard hourly rate of Owner's agent, plus related overhead and any direct non-salary costs. If Owner completes the repairs using another contractor, Contractor shall pay Owner the amount of Owner's direct costs billed by the other contractor for the work, plus the direct salary costs and related overhead and direct non-salary expenses of Owner's agents who

are required to monitor that contractor's work. Work performed by Owner using Owner's own agents or those of another contractor shall not affect the Contractor's contractual duties under these provisions, including warranty provisions.

- I.2.2 Nothing in this Section I.2 provision shall negate guarantees or warranties for periods longer than one year including without limitation, such guarantees or warranties required by other sections of the Contract Documents for specific installations, materials, processes, equipment or fixtures.
- I.2.3 In addition to Contractor's warranty, manufacturer's warranties shall pass to the Owner and shall not take effect until such portion of the Work covered by the applicable warranty has been accepted in writing by the Owner.
- I.2.4 The one-year period for correction of Work shall be extended with respect to portions of Work performed after Substantial Completion by the period of time between Substantial Completion and the actual performance of the Work, and shall be extended by corrective Work performed by the Contractor pursuant to this Section, as to the Work corrected. The Contractor shall remove from the Project Site portions of the Work which are not in accordance with the requirements of the Contract Documents and are neither corrected by the Contractor nor accepted by the Owner.
- I.2.5 Nothing contained in this Section I.2 shall be construed to establish a period of limitation with respect to other obligations which the Contractor might have under the Contract Documents. Establishment of the period for correction of Work as described in this Section I.2 relates only to the specific obligation of the Contractor to correct the Work, and has no relationship to the time within which the obligation to comply with the Contract Documents may be sought to be enforced, nor to the time within which proceedings may be commenced to establish the Contractor's liability with respect to the Contractor's obligations other than specifically to correct the Work.
- I.2.6 If the Owner prefers to accept Work which is not in accordance with the requirements of the Contract Documents, the Owner may do so instead of requiring its removal and correction, in which case the Contract Price will be reduced as appropriate and equitable as determined by Owner. Such adjustment shall be effected whether or not final payment has been made.

SECTION J

SUSPENSION AND/OR TERMINATION OF THE WORK

J.1 OWNER'S RIGHT TO SUSPEND THE WORK

- J.1.1 The Owner has the authority to suspend portions or all of the Work due to the following causes:
 - (a) Failure of the Contractor to correct unsafe conditions;
 - (b) Failure of the Contractor to carry out any provision of the Contract;
 - (c) Failure of the Contractor to carry out orders;
 - (d) Conditions, in the opinion of the Owner, which are unsuitable for performing the Work;
 - (e) Time required to investigate differing Project Site conditions; or
 - (f) Any reason considered to be in the public interest.
- J.1.2 The Owner shall notify Contractor and the Contractor's Surety in writing of the effective date and time of the suspension, and Owner shall notify Contractor and Contractor's surety in writing to resume Work.

J.2 CONTRACTOR'S RESPONSIBILITIES

- J.2.1 During the period of the suspension, Contractor is responsible to continue maintenance at the Project just as if the Work were in progress. This includes, but is not limited to, protection of completed Work, maintenance of access, protection of stored materials, temporary facilities, and clean-up.
- J.2.2 When the Work is recommenced after the suspension, the Contractor shall replace or renew any Work damaged during the suspension, remove any materials or facilities used as part of temporary maintenance, and complete the Work in every respect as though its prosecution had been continuous and without suspension.

J.3 COMPENSATION FOR SUSPENSION

Depending on the reason for suspension of the Work, the Contractor or the Owner may be due compensation by the other party. If the suspension was required due to acts or omissions of Contractor, the Owner may assess the Contractor actual costs of the suspension in terms of administration, remedial work by the Owner's agents or another contractor to correct the problem associated with the suspension, rent of temporary facilities, and other actual costs related to the suspension, and any liquidated damages arising from the delay. If the suspension was caused by acts or omissions of the Owner, the Contractor may be due compensation which shall be defined using Section D, Changes in Work. If the suspension was required through no fault of the Contractor or the Owner, neither party shall owe the other for the impact.

J.4 OWNER'S RIGHT TO TERMINATE CONTRACT

- J.4.1 The Owner may, without prejudice to any other right or remedy, and after giving Contractor seven (7) Days' written notice and an opportunity to cure, terminate the Contract in whole or in part under the following conditions:
 - (a) If Contractor should, voluntarily or involuntarily, seek protection under the United States Bankruptcy Code and Contractor as debtor-in-possession or the Trustee for the estate fails to assume the Contract within a reasonable time;
 - (b) If Contractor should make a general assignment for the benefit of Contractor's creditors;
 - (c) If a receiver should be appointed on account of Contractor's insolvency;
 - (d) If Contractor should repeatedly refuse or fail to supply an adequate number of skilled workers or proper materials to carry on the Work as required by the Contract Documents, or otherwise fail to perform the Work in a timely manner;
 - (e) If Contractor should repeatedly fail to make prompt payment to Subcontractors or for material or labor, or should disregard laws, ordinances or the instructions of the Owner;
 - (f) If Contractor is otherwise in breach of any part of the Contract; or
 - (g) If Contractor is in violation of Applicable Laws, either in the conduct of its business or in its performance of the Work.

- J.4.2 At any time that any of the above occurs, Owner may exercise all rights and remedies available to Owner at law or in equity, and, in addition, Owner may take possession of the premises and of all materials and appliances and finish the Work by whatever method it may deem expedient. In such case, the Contractor shall not be entitled to receive further payment until the Work is completed. If

the Owner's cost of finishing the Work exceeds the unpaid balance of the Contract Price, Contractor shall pay the difference to the Owner.

J.5 TERMINATION FOR CONVENIENCE, NON-APPROPRIATION OF FUNDS, OR FORCE MAJEURE

- J.5.1 Owner may terminate the Contract in whole or in part whenever Owner determines: (a) that termination of the Contract is in the best interest of Owner or the public; (b) that the Owner failed to receive funding, appropriations, allocations or other expenditure authority as contemplated by Owner's budget and Owner determines, in its sole determination, and its assessment and ranking of the policy objectives explicit or implicit in Owner's budget, Owner may determine it is necessary to and may terminate the Contract.; or (c) in the event of Force Majeure.
- J.5.2 The Owner shall provide the Contractor with seven (7) Days prior written notice of a termination for Owner's or for public convenience. After such notice, the Contractor shall provide the Owner with immediate and peaceful possession of the premises and materials located on and off the premises for which the Contractor received progress payment under Section E. Compensation for Work terminated by the Owner under this provision will be according to Section E. In no circumstance shall Contractor be entitled to lost profits for Work not performed due to termination. If the Contract is terminated for public convenience, neither the Contractor nor its Surety shall be relieved of liability for damages or losses suffered by the Owner as a result of defective, unacceptable or unauthorized Work completed or performed.

J.6 ACTION UPON TERMINATION

- J.6.1 Upon receiving a notice of termination, and except as directed otherwise by the Owner, Contractor shall immediately cease placing further subcontracts or orders for materials, services, or facilities. In addition, Contractor shall terminate all subcontracts or orders to the extent they relate to the Work terminated and, with the prior written approval of the Owner, settle all outstanding liabilities and termination settlement proposals arising from the termination of subcontracts and orders.
- J.6.2 As directed by the Owner, Contractor shall, upon termination, transfer title and deliver to the Owner all Record Documents, information, and other property that, if the Contract had been completed, would have been required to be furnished to the Owner.
- J.6.3 Upon Owner's notice of termination pursuant to either Section J.4 or J.5, if Owner shall so elect, Contractor shall assign to the Owner such subcontracts and orders as Owner shall specify. In the event Owner elects to take assignment of any such subcontract or order, Contractor shall take such action and shall execute such documents as Owner shall reasonably require for the effectiveness of such assignment and Contractor shall ensure that no contractual arrangement between it and its subcontractors or suppliers of any tier or sub-tier shall prevent such assignment.

SECTION K CONTRACT CLOSE OUT

K.1 RECORD DOCUMENTS

As a condition of final payment (refer also to section E.6), Contractor shall comply with the following: Contractor shall provide Record Documents for the entire Project to Owner. Record Documents shall depict the Project as constructed and shall reflect each and every change, modification, and deletion made during the construction. Record Documents are part of the Work and shall be provided prior to the Owner's issuance of final payment. Record Documents include all modifications to the Contract Documents unless otherwise directed.

K.2 OPERATION AND MAINTENANCE MANUALS

As part of the Work, Contractor shall submit two completed operation and maintenance manuals ("O & M Manuals") for review by the Owner prior to submission of any pay request for more than 75% of the Work. Owner's receipt of the O & M Manuals shall be a condition precedent to any payment thereafter due. The O & M Manuals shall contain a complete set of all submittals, all product data as required by the specifications, training information, telephone list and contact information for all consultants, manufacturers, installer and suppliers, manufacturer's printed data, record and shop drawings, schematic diagrams of systems, appropriate equipment indices, warranties and bonds. The Owner shall review and return one O & M Manual for any modifications or adjustments required. Prior to submission of its final pay request, Contractor shall deliver two (2) complete and approved sets of O & M Manuals in paper form and one (1) complete and approved set in electronic form to the Owner and Owner's receipt of the O & M Manuals shall be a condition precedent to Owner's obligation to make final payment.

K.3 COMPLETION NOTICES

- K.3.1 Contractor shall provide Owner written notice of both Substantial and Final Completion. The certificate of Substantial Completion shall state the date of Substantial Completion, the responsibilities of the Owner and Contractor for security, maintenance, heat, utilities, damage to the Work and insurance, and the time within which the Contractor shall finish all items on the Punch List accompanying the Certificate. Both completion notices must be signed and notarized by the Contractor and signed by the Architect/Engineer (if applicable) and Owner to be valid. The Owner shall provide the final signature on the notices. The notices shall take effect on the date they are signed by the Owner.
- K.3.2 Substantial Completion of a facility with operating systems (e.g., mechanical, electrical, HVAC) shall be that degree of completion that has provided a minimum of thirty (30) continuous Days of successful, trouble-free operation, which period shall begin after all performance and acceptance testing has been successfully demonstrated to the Owner. All equipment contained in the Work, plus all other components necessary to enable the Owner to operate the facility in the manner that was intended, shall be complete on the Substantial Completion date. The Contractor may request that a Punch List be prepared by the Owner with submission of the request for the Substantial Completion notice.

K.4 TRAINING

As part of the Work, and prior to submission of the final application for payment, the Contractor shall schedule with the Owner training sessions for all equipment and systems as required by the Contract Documents. Contractor shall schedule training sessions at least two weeks in advance of the date of training to allow Owner to provide its personnel with adequate notice. If assignments arise because of termination under Section J.4, then such assignments shall not relieve Contractor of liability hereunder. The O & M Manual shall be used as a basis for training. In addition to any off-Project Site training required by the Contract Documents, training shall include a formal session conducted at the Project Site after the equipment and/or system is completely installed and operational in its normal operating environment.

K.5 EXTRA MATERIALS

As part of the Work, Contractor shall provide spare parts, extra maintenance materials, and other materials or products in the quantities specified in the Contract Documents prior to final payment. Delivery point for extra materials shall be designated by the Owner.

K.6 ENVIRONMENTAL CLEAN-UP

As part of the Final Completion notice, or as a separate written notice submitted with or before the notice of Final Completion, the Contractor shall notify the Owner that all environmental and pollution clean-up, remediation and closure have been completed in accordance with all Applicable Laws and pursuant to the authority of all agencies having jurisdiction, and Contractor shall provide Owner with any and all documentation related to the same, including but not limited to directives, orders, letters, certificates and permits related to or arising from such environmental pollution. The notice shall reaffirm the indemnification given under Section F.5.1 above. Contractor's completion of its obligations under this Section K.6 and Owner's receipt of documents evidencing such completion shall be a condition precedent to Owner's obligation to make final payment.

K.7 CERTIFICATE OF OCCUPANCY

Owner's receipt of an unconditioned certificate of occupancy from the appropriate state and/or local building officials shall be a condition precedent to Owner's obligation to make final payment, except to the extent failure to obtain an unconditional certificate of occupancy is due to the fault or neglect of Owner.

K.8 OTHER CONTRACTOR RESPONSIBILITIES

The Contractor shall be responsible for returning to the Owner all property of Owner issued to Contractor during construction such as keys, security passes, Project Site admittance badges, and all other pertinent items. Upon notice from Owner, Contractor shall be responsible for notifying the appropriate utility companies to transfer utility charges from the Contractor to the Owner. The utility transfer date shall not be before Substantial Completion and may not be until Final Completion, if the Owner does not take beneficial use of the facility and the Contractor's agents continue with the Work.

The Owner's property is drug free and weapons free areas and the use of tobacco products is only allowed in designated areas. Contractor shall be required to ensure that its employees, Subcontractors and agents shall comply with these requirements.

SECTION L GENERAL PROVISIONS

L.1 NO THIRD PARTY BENEFICIARIES

Owner and Contractor are the only parties to the Contract and are the only parties entitled to enforce its terms. Nothing in the Contract gives, is intended to give, or shall be construed to give or provide any benefit or right, whether directly, indirectly, or otherwise, to third persons unless such third persons are individually identified by name herein and expressly described as intended beneficiaries of the terms of the Contract.

L.2 SEVERABILITY

If any provision of the Contract is declared by a court to be unenforceable, illegal, or in conflict with any law, the validity of the remaining terms and provisions shall not be affected and the rights and obligations of the parties shall be construed and enforced as if the Contract did not contain the particular provision held to be invalid.

L.3 ACCESS TO RECORDS

L.3.1 Contractor shall keep, at all times on the Project Site, one record copy of the complete Contract Documents, including the Plans, Specifications, addenda, and Change Orders (if any) in good order and marked currently to record field changes and selections made during construction, and one record copy of Shop Drawings, Product Data, Samples and similar submittals, and shall at all times give the Owner access thereto.

L.3.2 Contractor shall retain and the Owner and its duly authorized representatives shall have access, for a period not less than ten (10)

years, to all Record Documents, financial and accounting records, and other books, documents, papers and records of Contractor which are pertinent to the Contract, including records pertaining to Overhead and indirect costs, for the purpose of making audit, examination, excerpts and transcripts. If for any reason, any part of the Work or the Contract shall be subject to litigation, Contractor shall retain all such records until all litigation is resolved and Contractor shall continue to provide Owner and/or its agents with full access to such records until such time as all litigation is complete and all periods for appeal have expired and full and final satisfaction of any judgment, order or decree is recorded and Owner receives a record copy of documentation from Contractor.

L.4 WAIVER

Failure of the Owner to enforce any provision of the Contract shall not constitute a waiver or relinquishment by the Owner of the right to such performance in the future nor of the right to enforce any other provision of the Contract.

L.5 SUCCESSORS IN INTEREST

The provisions of the Contract shall be binding upon and shall accrue to the benefit of the parties to the Contract and their respective permitted successors and assigns.

L.6 GOVERNING LAW

The Contract shall be governed by and construed in accordance with the laws of the State of Oregon without giving effect to the conflict of law provisions thereof.

L.7 APPLICABLE LAW

Contractor hereto agrees to comply in all ways with applicable local, state and federal ordinances, statutes, laws and regulations.

L.8 NON-EXCLUSIVE RIGHTS AND REMEDIES

Except as otherwise expressly provided herein, the rights and remedies expressly afforded under the provisions of the Contract shall not be deemed exclusive, and shall be in addition to and cumulative with any and all rights and remedies otherwise available at law or in equity. The exercise by either Party of any one or more of such remedies shall not preclude the exercise by it, at the same or different times, of any other remedies for the same default or breach, or for any other default or breach, by the other Party.

L.9 INTERPRETATION

The titles of the sections of the Contract are inserted for convenience of reference only and shall be disregarded in construing or interpreting any of its provisions.

L.10 DEBT LIMITATION

The Contract is expressly subject to the debt limitation of Oregon counties set forth in Article XI, Section 10, of the Oregon Constitution, and is contingent upon funds being appropriated therefore. Any provisions herein which would conflict with law are deemed inoperative to that extent.

L.11 LITIGATION

Any Claim between Owner and Contractor that arises from or relates to the Contract and that is not resolved through the Claims Review Process in Section D.3 shall be brought and conducted solely and exclusively within the Circuit Court of Clackamas County for the State of Oregon; provided, however, if a Claim must be brought in a federal forum, then it shall be brought and conducted solely and exclusively within the United States District Court for the District of Oregon. In no event shall this section be construed as a waiver by the County of any form of defense or

immunity, whether sovereign immunity, governmental immunity, immunity based on the Eleventh Amendment to the Constitution of the United States or otherwise, from any claim or from the jurisdiction of any court. CONTRACTOR, BY EXECUTION OF THE CONTRACT, HEREBY CONSENTS TO THE IN PERSONAM JURISDICTION OF THE COURTS REFERENCED IN THIS SECTION.

L. 12 SURVIVAL

All warranty, indemnification, and record retention provisions of the Contract, and all of Contractor's other obligations under the Contract that are not fully performed by the time of Final Completion or termination, and all other rights and obligations which by their context are intended to survive, shall survive Final Completion or any termination of the Contract.

L.13 ACCESS TO RECORDS

L.13.1. Contractor shall keep, at all times on the Work site, one record copy of the complete Contract Documents, including the Plans, Specifications, Construction Change Directives and addenda, in good order and marked currently to record field changes and selections made during construction, and one copy of Shop Drawings, Project Data, Samples and similar submittals, and shall at all times give the Owner access thereto.

L.13.2 Contractor shall retain and the Owner and its duly authorized representatives shall have access, for a period not less than ten (10) years, to all Record Documents, financial and accounting records, and other books, documents, papers and records of Contractor which are pertinent to the Contract, including records pertaining to Overhead and indirect costs, for the purpose of making audit, examination, excerpts and transcripts. If for any reason, any part of the Work or this Contract shall be subject to litigation, Contractor shall retain all such records until all litigation is resolved and Contractor shall continue to provide Owner and/or its agents with full access to such records until such time as all litigation is complete and all periods for appeal have expired and full and final satisfaction of any judgment, order or decree is recorded and Owner receives a record copy of documentation from Contractor.

L.14 WAIVER

Failure of the Owner to enforce any provision of this Contract shall not constitute a waiver or relinquishment by the Owner of the right to such performance in the future nor of the right to enforce any other provision of this Contract.

L. 15 NO ATTORNEY FEES.

In the event any arbitration, action or proceeding, including any bankruptcy proceeding, is instituted to enforce any term of this Contract, each party shall be responsible for its own attorneys' fees and expenses.

arising out of the performance of the Contract by the Principal or its subcontractors, and shall in all respects perform said contract according to law, then this obligation is to be void; otherwise, it shall remain in full force and effect for so long as any term of the Contract remains in effect.

Nonpayment of the bond premium will not invalidate this bond nor shall Clackamas County, be obligated for the payment of any premiums.

This bond is given and received under authority of Oregon Revised Statutes Chapter 279C and the Clackamas County Local Contractor Review Board Rules, the provisions of which hereby are incorporated into this bond and made a part hereof.

IN WITNESS WHEREOF, WE HAVE CAUSED THIS INSTRUMENT TO BE EXECUTED AND SEALED BY OUR DULY AUTHORIZED LEGAL REPRESENTATIVES.

Dated this 11th day of June, 2024.

PRINCIPAL: Becmen LLC

By: Joshy Bae
Signature

MANAGING MEMBER
Official Capacity

Attest: _____
Corporation Secretary

SURETY: WESTERN SURETY COMPANY
[Add signatures for each if using multiple bonds]

BY ATTORNEY-IN-FACT:
[Power-of-Attorney must accompany each bond]

TAMARA LYNN REINECKE WONG

T. Reinecke Wong
Name
Signature

151 N. Franklin, 17th Floor

Chicago IL 60606
Address

605-336-0850 605-335-0357
City State Zip

Phone Fax



**CLACKAMAS COUNTY
PUBLIC IMPROVEMENT CONTRACT**

PAYMENT BOND

Bond No.: 67090560
Solicitation: 2024-31
Project Name: Metal Framing, Insulation, and Drywall for Lake Road Health Center
WESTERN SURETY

COMPANY (Surety #1)	Bond Amount No. 1:	\$ <u>288,000.00</u>
(Surety #2)*	Bond Amount No. 2:*	\$ <u> </u>
* <i>If using multiple sureties</i>		Total Penal Sum of Bond: \$ <u>288,000.00</u>

We, Becmen LLC, as Principal, and the above identified Surety(ies), authorized to transact surety business in Oregon, as Surety, hereby jointly and severally bind ourselves, our respective heirs, executors, administrators, successors and assigns firmly by these presents to pay unto Clackamas County, the sum of (Total Penal Sum of Bond) Two Hundred Eighty Eight Thousand and no/100 (\$288,000.00) (Provided, that we the Sureties bind ourselves in such sum "jointly and severally" as well as "severally" only for the purpose of allowing a joint action or actions against any or all of us, and for all other purposes each Surety binds itself, jointly and severally with the Principal, for the payment of such sum only as is set forth opposite the name of such Surety); and

WHEREAS, the Principal has entered into a contract with Clackamas County, along with the plans, specifications, terms and conditions of which are contained in above-referenced Solicitation; and

WHEREAS, the terms and conditions of the contract, together with applicable plans, standard specifications, special provisions, schedule of performance, and schedule of contract prices, are made a part of this Payment Bond by reference, whether or not attached to the contract (all hereafter called "Contract"); and

WHEREAS, the Principal has agreed to perform the Contract in accordance with the terms, conditions, requirements, plans and specifications, and schedule of contract prices which are set forth in the Contract and any attachments, and all authorized modifications of the Contract which increase the amount of the work, or the cost of the Contract, or constitute authorized extensions of time for performance of the Contract, notice of any such modifications hereby being waived by the Surety:

NOW, THEREFORE, THE CONDITION OF THIS BOND IS SUCH that if the Principal shall faithfully and truly observe and comply with the terms, conditions and provisions of the Contract, in all respects, and shall well and truly and fully do and perform all matters and things by it undertaken to be performed under said Contract and any duly authorized modifications that are made, upon the terms set forth therein, and within the time prescribed therein, or as extended therein as provided in the Contract, with or without notice to the Sureties, and shall defend, indemnify, and save harmless Clackamas County and its elected officials, officers, employees and agents, against any claim for direct or indirect damages of every kind and description that shall be suffered or claimed to be suffered in connection with or arising out of the performance of the Contract by the Contractor or its subcontractors, and shall promptly pay all persons supplying labor, materials or both to the Principal or its subcontractors for prosecution of the work provided in the Contract, and shall promptly pay all contributions due the State Industrial Accident Fund and the State Unemployment Compensation Fund from the Principal or its subcontractors in connection with the performance of the Contract; and shall pay over to the Oregon Department of Revenue all sums required to be deducted and retained from the wages of employees of the Principal and its subcontractors pursuant to ORS 316.167, and

shall permit no lien nor claim to be filed or prosecuted against Clackamas County on account of any labor or materials furnished; and shall do all things required of the Principal by the laws of this State, then this obligation shall be void; otherwise, it shall remain in full force and effect for so long as any term of the Contract remains in effect.

Nonpayment of the bond premium will not invalidate this bond nor shall Clackamas County be obligated for the payment of any premiums.

This bond is given and received under authority of Oregon Revised Statutes Chapter 279C and the Clackamas County Local Contractor Review Board Rules, the provisions of which hereby are incorporated into this bond and made a part hereof.

IN WITNESS WHEREOF, WE HAVE CAUSED THIS INSTRUMENT TO BE EXECUTED AND SEALED BY OUR DULY AUTHORIZED LEGAL REPRESENTATIVES:

Dated this 11th day of June, 2024.

PRINCIPAL: Becmen LLC

By: Josif Bec
Signature

Managing Member
Official Capacity

Attest: _____
Corporation Secretary

SURETY: WESTERN SURETY COMPANY
[Add signatures for each if using multiple bonds]

BY ATTORNEY-IN-FACT:
[Power-of-Attorney must accompany each bond]

TAMARA LYNN REINECKE WONG

Tamara Lynn Reinecke Wong
Name
Signature

151 N. Franklin, 17th Floor
Address

Chicago IL 60606
City State Zip

605-336-0850 605-335-0357
Phone Fax

Western Surety Company

POWER OF ATTORNEY - CERTIFIED COPY

Bond No. 67090560

Know All Men By These Presents, that WESTERN SURETY COMPANY, a corporation duly organized and existing under the laws of the State of South Dakota, and having its principal office in Sioux Falls, South Dakota (the "Company"), does by these presents make, constitute and appoint Tamara Lynn Reinecke Wong

its true and lawful attorney(s)-in-fact, with full power and authority hereby conferred, to execute, acknowledge and deliver for and on its behalf as Surety, bonds for:

Principal: Becmen LLC

Obligee: County of Clackamas County

Amount: \$3,000,000.00

and to bind the Company thereby as fully and to the same extent as if such bonds were signed by the Vice President, sealed with the corporate seal of the Company and duly attested by its Secretary, hereby ratifying and confirming all that the said attorney(s)-in-fact may do within the above stated limitations. Said appointment is made under and by authority of the following bylaw of Western Surety Company which remains in full force and effect.

"Section 7. All bonds, policies, undertakings, Powers of Attorney or other obligations of the corporation shall be executed in the corporate name of the Company by the President, Secretary, any Assistant Secretary, Treasurer, or any Vice President or by such other officers as the Board of Directors may authorize. The President, any Vice President, Secretary, any Assistant Secretary, or the Treasurer may appoint Attorneys in Fact or agents who shall have authority to issue bonds, policies, or undertakings in the name of the Company. The corporate seal is not necessary for the validity of any bonds, policies, undertakings. Powers of Attorney or other obligations of the corporation. The signature of any such officer and the corporate seal may be printed by facsimile."

This Power of Attorney may be signed by digital signature and sealed by a digital or otherwise electronic-formatted corporate seal under and by the authority of the following Resolution adopted by the Board of Directors of the Company by unanimous written consent dated the 27th day of April, 2022:

"RESOLVED: That it is in the best interest of the Company to periodically ratify and confirm any corporate documents signed by digital signatures and to ratify and confirm the use of a digital or otherwise electronic-formatted corporate seal, each to be considered the act and deed of the Company."

If Bond No. 67090560 is not issued on or before midnight of November 15th, 2024, all authority conferred in this Power of Attorney shall expire and terminate.

In Witness Whereof, Western Surety Company has caused these presents to be signed by its Vice President, Larry Kasten, and its corporate seal to be affixed this 11th day of June 2024.

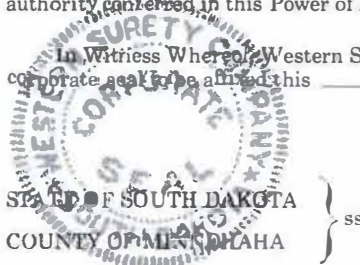

WESTERN SURETY COMPANY

Larry Kasten
Larry Kasten, Vice President

On this 11th day of June, in the year 2024, before me, a notary public, personally appeared Larry Kasten, who being to me duly sworn, acknowledged that he signed the above Power of Attorney as the aforesaid officer of WESTERN SURETY COMPANY and acknowledged said instrument to be the voluntary act and deed of said corporation.

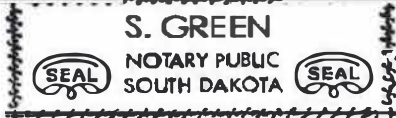

My Commission Expires February 12, 2027

S. Green
Notary Public - South Dakota

I the undersigned officer of Western Surety Company, a stock corporation of the State of South Dakota, do hereby certify that the attached Power of Attorney is in full force and effect and is irrevocable, and furthermore, that Section 7 of the bylaws of the Company as set forth in the Power of Attorney is now in force.

In testimony whereof, I have hereunto set my hand and seal of Western Surety Company this 11th day of June 2024.

WESTERN SURETY COMPANY

Larry Kasten
Larry Kasten, Vice President

To validate bond authenticity, go to www.cnasurety.com > Owner/Obligee Services > Validate Bond Coverage.



CLACKAMAS COUNTY
PUBLIC IMPROVEMENT CONTRACT
PROJECT INFORMATION, PLANS, SPECIFICATIONS AND DRAWINGS

PROJECT: BID# 2024-31 Metal Framing, Insulation, and Drywall for Lake Road Health Center

Background

Clackamas County Facilities Management, acting as a general contractor, is soliciting bids from qualified Contractors to complete various components of a 41,739 square foot remodel of a County owned building. The Lake Road Health Center is a three-story building located at 6605 SE Lake Rd, Milwaukie, Oregon 97222. The building was built in 1992 and sits on 2.37 acres. Clackamas County proposed improvements include office and bathroom build outs within the existing building envelope as indicated in the Contract Documents. Subcontracted work includes the following: Non-structural, interior steel wall framing; STC sound dampening insulation; and drywall. A single contract shall be awarded to the lowest and most responsive bidder for this work.

Project Scope:

The Contractor shall supply all materials and labor to complete their portion of the project in compliance with all local codes and regulations according to specifications and detailed requirements specified below.

Work includes, but is not limited to, the following: Non-structural, interior steel wall framing; Sound Transmission Class (“STC”) noise dampening insulation; and drywall. Work requirements are described in the attached drawings and the following specifications.

DETAILED REQUIREMENTS

1. The Contractor shall be responsible for supplying, fabricating, delivering and installing all required materials and labor to include incidentals to complete the scope of work detailed in the specifications and as directed by the County.
 - a. Primary requirements for this work can be found in, but not limited to this document and Construction Drawings.
 - b. Proposed framing, insulation, and drywall materials must be comparable or better to existing components.
2. The contractor shall furnish the County with an industry standard written warranty for defects in work performed covering parts, equipment, and labor for the work being performed. This warranty shall be furnished in addition to any standard manufacturer’s warranties. The contractor shall also provide related operation manuals if any pertain, and system operational training to designated County staff.
3. Care and diligence must be used to avoid any damages to the existing facility. Any damage incurred through the Subcontractors operations will be the sole responsibility of the Subcontractor. A limited staging area adjacent to the work area can be provided. The staging area, work site and all areas impacted or used by the Subcontractor shall be clean

and clear of construction materials on a daily basis at the end of the work shift. All debris and waste shall be removed from the facility and disposed of properly at the completion of the project. Any materials paid for by the County and not incorporated into the project shall become the property of the County and remain at the project site.

4. The Subcontractor shall work with and make accommodations for any and all required inspections from the presiding jurisdiction and/or special inspections from third party inspectors. The Subcontractor shall be responsible for scheduling all required inspections. The County shall be made aware of any corrections required, and the Subcontractor shall immediately repair or replace any substandard work. Copies of the original inspection sheet(s) shall be provided to the County.
5. The work areas are located on the 1st Floor, 2nd Floor, and 3rd Floor.

Key Dates:

All Basic Bid Work may begin as soon as the Notice to Proceed (“NTP”) is issued

Substantial Completion: August 1, 2024

Final Completion: August 30, 2024

The Scope further includes the following Plans, Specifications and Drawings:

- Lake Rd Health Center Construction Documents- Section 07 21 00-Thermal Insulation (2 Pages)
- Lake Rd Health Center Construction Documents- Section 07 84 00- Fire Stopping (2 pages)
- Lake Rd Health Center Construction Documents- Section 07 84 00- Joint Sealers (3 pages)
- Lake Rd Health Center Construction Documents- Section 09 21 16- Gypsum Board Assemblies (5 pages)
- Division 9- Non – Structural Metal Framing (4 pages)
- Thermal Insulation- (2 pages)
- Non-Load Bearing Wall Framing Systems (11 pages)
- Framing Drawing Set- page S1.11, S1.12, S6.00, S6.01, S6.10, S6.11 (7 Pages)

THERMAL INSULATION

PART 1 GENERAL

1.01 SECTION INCLUDES

- A. Batt insulation interior wall construction.
- B. Batt insulation for filling perimeter window and door shim spaces, and crevices in walls and roof.
- C. Spray foam insulation for gap closure where required.

1.02 REFERENCE STANDARDS

- A. ASTM E136 - Standard Test Method for Behavior of Materials in a Vertical Tube Furnace At 750 Degrees C; 2012.

1.03 SUBMITTALS

- A. Product Data: Provide data on product characteristics, performance criteria, and product limitations.
- B. Manufacturer's Installation Instructions: Include information on special environmental conditions required for installation and installation techniques.
- C. Manufacturer's Certificate: Certify that products meet or exceed specified requirements.

1.04 FIELD CONDITIONS

- A. Do not install insulation adhesives when temperature or weather conditions are detrimental to successful installation.

PART 2 PRODUCTS

2.01 BATT INSULATION MATERIALS

- A. Glass Fiber Batt Insulation: Flexible preformed batt or blanket, complying with ASTM C 655; friction fit.
 - 1. Combustibility: Non-combustible, when tested in accordance with ASTM E136, except for facing, if any.
 - 2. Formaldehyde Content: Zero.
 - 3. Thermal Resistance: R of 3.6 per inch.
 - 4. Facing: Unfaced at acoustical insulation applications.
 - 5. Facing: Aluminum foil, one side for furred exterior wall cavity locations.

2.02 SPRAY FOAM INSULATION

- A. Insulating Foam Sealant:
 - 1. Design Basis: Great Stuff by Dow.
 - a. Use product with appropriate expansion qualities around exterior envelope openings to ensure expansion does not displace opening components in a way that impedes installation of opening components, or operation of installed components.
 - 2. Locations: Between building opening components and wall cavity, voids at interfacing envelope components to provide continuous continuity of building thermal envelope.

2.03 FOAMED-IN-PLACE INSULATION

- A. Foamed-In-Place Insulation:
 - 1. Design Basis: See Section 07 21 19.

2.04 ACCESSORIES

- A. Tape: Bright aluminum self-adhering type, mesh reinforced, 2 inch wide.
- B. Adhesive: Type recommended by insulation manufacturer for application.
- C. Mesh Insulation Netting: 1 x 2 inch mesh netting size.
 - 1. Fasteners: Appropriate for purpose intended and approved for netting applications.

THERMAL INSULATION

PART 3 EXECUTION

3.01 BATT INSTALLATION

- A. Install insulation and vapor retarder in accordance with manufacturer's instructions.
- B. Install in exterior wall and roof spaces without gaps or voids. Do not compress insulation.
- C. Trim insulation neatly to fit spaces. Insulate miscellaneous gaps and voids.
- D. Fit insulation tightly in cavities and tightly to exterior side of mechanical and electrical services within the plane of the insulation.

END OF SECTION

FIRE STOPPING

PART 1 GENERAL

1.01 SECTION INCLUDES

- A. Firestopping systems.
- B. Firestopping of all penetrations, perimeters and interruptions to fire rated assemblies, whether indicated on drawings or not, and other openings indicated.

1.02 REFERENCE STANDARDS

- A. ASTM E814 - Standard Test Method for Fire Tests of Penetration Firestop Systems; 2013a.
- B. ITS (DIR) - Directory of Listed Products; Intertek Testing Services NA, Inc.; current edition.
- C. FM P7825 - Approval Guide; Factory Mutual Research Corporation; current edition.
- D. SCAQMD 1168 - South Coast Air Quality Management District Rule No. 1168; current edition; www.aqmd.gov.
- E. UL (FRD) - Fire Resistance Directory; Underwriters Laboratories Inc.; current edition.

1.03 SUBMITTALS

- A. Schedule of Firestopping: List each type of penetration.
- B. Product Data: Provide data on product characteristics.
- C. Manufacturer's Installation Instructions: Indicate preparation and installation instructions.
- D. Manufacturer's Certificate: Certify that products meet or exceed specified requirements.
- E. Qualification statements for installing mechanics.

1.04 QUALITY ASSURANCE

- A. Fire Testing: Provide firestopping assemblies of designs that provide the specified fire ratings when tested in accordance with methods indicated.
 - 1. Listing in the current-year classification or certification books of UL, FM, or ITS (Warnock Hersey) will be considered as constituting an acceptable test report.
- B. Manufacturer Qualifications: Company specializing in manufacturing the products specified in this section with minimum 10 years documented experience.
 - 1. Provide products from a single manufacturer.
- C. Installer Qualifications: Company specializing in performing the work of this section and:
 - 1. Able to show at least 10 satisfactorily completed projects of comparable size and type.
 - 2. Licensed or approved by authority having jurisdiction.
 - 3. Approved by firestopping manufacturer.
- D. Installing Mechanic's Qualifications: Trained by firestopping manufacturer and able to provide evidence thereof.
- E. Pre-Installation Conference: Include AHJ inspector.

1.05 MOCK-UP

- A. Install one firestopping assembly representative of each fire rating design required on project.
 - 1. Where one design may be used for different penetrating items or in different wall constructions, install one assembly for each different combination.
- B. If accepted, mock-up will represent minimum standard for the Work.
- C. If accepted, mock-up may remain as part of the Work. Remove and replace mock-ups not accepted.

1.06 FIELD CONDITIONS

- A. Comply with firestopping manufacturer's recommendations for temperature and conditions during and after installation. Maintain minimum temperature before, during, and for 3 days after installation of materials.
- B. Do not install work until work area is dry and moisture will not be present for at least 3 days.

FIRESTOPPING

PART 2 PRODUCTS

2.01 FIRESTOPPING - GENERAL REQUIREMENTS

- A. Primers, Sleeves, Forms, Insulation, Packing, Stuffing, and Accessories: Type required for tested assembly design.

2.02 MANUFACTURERS

- A. Provide products that comply with requirements from a single manufacturer, one of the following:
 1. Grace, W. R. & Co. - Conn.
 2. Hilti, Inc.
 3. Johns Manville.
 4. Specified Technologies Inc.
 5. 3M; Fire Protection Products Division.

2.03 FIRESTOPPING SYSTEMS

- A. Firestopping: Any material meeting requirements.
 1. Fire Ratings: Use any system listed by UL or tested in accordance with ASTM E 814 that has F Rating equal to fire rating of penetrated assembly and minimum T Rating Equal to F Rating and that meets all other specified requirements.

2.04 MATERIALS

- A. Firestopping Sealants: Provide only products having lower volatile organic compound (VOC) content than required by South Coast Air Quality Management District Rule No.1168.
- B. Provide paintable surface material where firestopping is exposed to view, excluding maintenance areas.
- C. Primers, Sleeves, Forms, Insulation, Packing, Stuffing, and Accessories: Type required for tested assembly design.

PART 3 EXECUTION

3.01 EXAMINATION

- A. Verify openings are ready to receive the work of this section.

3.02 PREPARATION

- A. Clean substrate surfaces of dirt, dust, grease, oil, loose material, or other matter that could adversely affect bond of firestopping material.
- B. Remove incompatible materials that could adversely affect bond.

3.03 INSTALLATION

- A. Install materials in manner described in fire test report and in accordance with manufacturer's instructions, completely closing openings.
- B. Do not cover installed firestopping until inspected by authority having jurisdiction.
- C. Install labeling required by code.

3.04 PROTECTION

- A. Protect adjacent surfaces from damage by material installation.

END OF SECTION

JOINT SEALERS

PART 1 GENERAL

1.01 SECTION INCLUDES

- A. Sealants and joint backing.
- B. Precompressed foam sealers.
- C. Hollow gaskets.

1.02 REFERENCE STANDARDS

- A. ASTM C 1193 - Standard Guide for Use of Joint Sealants; 2005a.

1.03 ADMINISTRATIVE REQUIREMENTS

- A. Coordinate the work with other sections referencing this section.

1.04 SUBMITTALS

- A. Product Data: Provide data indicating sealant chemical characteristics.
- B. Manufacturer's Installation Instructions: Indicate special procedures.
- C. Preconstruction Field Test Reports: Indicate which sealants and joint preparation methods resulted in optimum adhesion to joint substrates based on preconstruction testing specified in "Quality Assurance" Article.
- D. Compatibility and Adhesion Test Reports: From sealant manufacturer, indicating the following:
 - 1. Materials forming joint substrates and joint-sealant backings have been tested for compatibility and adhesion with joint sealants.
 - 2. Interpretation of test results and written recommendations for primers and substrate preparation needed for adhesion.
- E. Warranties: Special warranties specified in this Section.

1.05 QUALITY ASSURANCE

- A. Applicator Qualifications: Company specializing in performing the work of this section with minimum 10 years of experience or approved by Manufacturer.
- B. Preconstruction Field-Adhesion Testing: Before installing elastomeric sealants, field test their adhesion to Project joint substrates as follows:
 - 1. Locate test joints where indicated on Project or, if not indicated, as directed by Architect.
 - 2. Conduct field tests for each application of elastomeric sealant and joint substrate indicated.
 - 3. Notify Architect seven days in advance of dates and times when test joints will be erected.
 - 4. Arrange for tests to take place with joint-sealant manufacturer's technical representative present.
 - 5. Test Method: Test joint sealants according to Method A, Field-Applied Sealant Joint Hand Pull Tab, in Appendix X1 in ASTM C 1193.
 - 6. Report whether sealant in joint connected to pulled-out portion failed to adhere to joint substrates or tore cohesively. Include data on pull distance used to test each type of product and joint substrate. For sealants that fail adhesively, retest until satisfactory adhesion is obtained.
 - 7. Evaluation of Preconstruction Field-Adhesion-Test Results: Sealants not evidencing adhesive failure from testing, in absence of other indications of noncompliance with requirements, will be considered satisfactory. Do not use sealants that fail to adhere to joint substrates during testing.

1.06 MOCK-UP

- A. Provide mock-up of sealant joints in conjunction with window, wall, and doors.
- B. Construct mock-up with specified sealant types and with other components noted.
- C. Locate where directed.
- D. Mock-up may remain as part of the Work.

JOINT SEALERS

1.07 FIELD CONDITIONS

- A. Maintain temperature and humidity recommended by the sealant manufacturer during and after installation.

1.08 COORDINATION

- A. Coordinate the work with all sections referencing this section.

1.09 WARRANTY

- A. Correct defective work within a 10 year period after Date of Substantial Completion.
- B. Warranty: Include coverage for installed sealants and accessories which fail to achieve airtight seal, watertight seal, and non-bleeding, exhibit loss of adhesion or cohesion, or do not cure.

PART 2 PRODUCTS

2.01 SEALANTS

- A. Provide only products having lower volatile organic compound (VOC) content than required by South Coast Air Quality Management District Rule No.1168.
 - 1. VOC Content: Provide sealants and sealant primers that comply with the following limits for VOC content when calculated according to 40 CFR 59, Subpart D (EPA Method 24):
 - a. Architectural Sealants: 250 g/L.
 - b. Roofing Sealant: 300 g/L.
 - c. Single Ply Membrane Sealer: 450 g/L.
 - d. Other sealants: 420 g/L.
 - e. Primers for Nonporous Substrates: 250 g/L.
 - f. Primers for Porous Substrates: 775 g/L.
- B. Compatibility: Provide joint sealants, backings, and other related materials that are compatible with one another and with joint substrates under conditions of service and application, as demonstrated by sealant manufacturer, based on testing and field experience.
- C. Elastomeric Sealants: Comply with ASTM C 920 and other requirements indicated for each liquid-applied chemically curing sealant specified, including those referencing ASTM C 920 classifications for type, grade, class, and uses related to exposure and joint substrates.
- D. Stain-Test-Response Characteristics: Provide products that have undergone testing according to ASTM C 1248 and have not stained porous joint substrates indicated for Project.
- E. Exterior Building Joint Sealant: Dow Corning 795, for vertical joints including:
 - 1. Panel joints
 - 2. Joints between products
 - 3. Joints in sheet metal fabrications
- F. Exterior Building Joint Sealant, non-bleeding: Dow Corning 756 SMS.
 - 1. Use in contact with stone or ceramic tile to assure no bleeding.
 - 2. Provide non-staining warranty
- G. Exterior Pavement Joint Sealant: Sonneborn SL-2, 2-part urethane
- H. Interior Horizontal Concrete Joint Sealant: Sonneborn Epolith-P, 2-part epoxy
- I. Interior Vertical Joint Sealant: Sonneborn Sonolac, 1-part acrylic
- J. Interior Bath and Toilet Room Sealant: GE Sanitary 1700 or Dow 786, silicone
- K. Interior Acoustical Joint Sealant: Nondrying, nonhardening, nonskinning, nonstaining, gunnable, synthetic rubber sealant formulated for sealing interior concealed joints to reduce transmission of airborne sound, complying with ASTM C919. Protective Treatments, Inc. PTI 808 Acoustical Sealant.
- L. Colors: Selected from full range except where custom color is specified.

2.02 ACCESSORIES

- A. Primer: Non-staining type, recommended by sealant manufacturer to suit application.

JOINT SEALERS

- B. Joint Cleaner: Non-corrosive and non-staining type, recommended by sealant manufacturer; compatible with joint forming materials.
- C. Joint Backing: Round foam rod compatible with sealant; ASTM D 1667, closed cell PVC; oversized 30 to 50 percent larger than joint width.
- D. Bond Breaker: Pressure sensitive tape recommended by sealant manufacturer to suit application.

PART 3 EXECUTION

3.01 EXAMINATION

- A. Verify that substrate surfaces are ready to receive work.
- B. Verify that joint backing and release tapes are compatible with sealant.

3.02 PREPARATION

- A. Remove loose materials and foreign matter that could impair adhesion of sealant.
- B. Clean and prime joints in accordance with manufacturer's instructions.
- C. Perform preparation in accordance with manufacturer's instructions and ASTM C1193.
- D. Protect elements surrounding the work of this section from damage or disfigurement.

3.03 INSTALLATION

- A. Perform work in accordance with sealant manufacturer's requirements for preparation of surfaces and material installation instructions.
- B. Perform installation in accordance with ASTM C1193.
- C. Install bond breaker where joint backing is not used.
- D. Install sealant free of air pockets, foreign embedded matter, ridges, and sags.
- E. Apply sealant within recommended application temperature ranges. Consult manufacturer when sealant cannot be applied within these temperature ranges.
- F. Tool joints concave.

3.04 CLEANING

- A. Clean adjacent soiled surfaces.

3.05 PROTECTION

- A. Protect sealants until cured.

END OF SECTION

GYPSUM BOARD ASSEMBLIES

PART 1 GENERAL

1.01 SECTION INCLUDES

- A. Performance criteria for gypsum board assemblies.
- B. Metal framing for interior partitions, ceilings and soffits.
- C. Metal channel ceiling framing.
- D. Gypsum wallboard.
- E. Joint treatment and accessories.
- F. Textured finish system.

1.02 REFERENCE STANDARDS

- A. ASTM C475/C475M - Standard Specification for Joint Compound and Joint Tape for Finishing Gypsum Board; 2012.
- B. ASTM C665 - Standard Specification for Mineral-Fiber Blanket Thermal Insulation for Light Frame Construction and Manufactured Housing; 2012.
- C. ASTM C754 - Standard Specification for Installation of Steel Framing Members to Receive Screw-Attached Gypsum Panel Products; 2011.
- D. ASTM C840 - Standard Specification for Application and Finishing of Gypsum Board; 2013.
- E. ASTM C954 - Standard Specification for Steel Drill Screws for the Application of Gypsum Panel Products or Metal Plaster Bases to Steel Studs From 0.033 in. (0.84 mm) to 0.112 in. (2.84 mm) in Thickness; 2011.
- F. ASTM C1002 - Standard Specification for Steel Self-Piercing Tapping Screws for the Application of Gypsum Panel Products or Metal Plaster Bases to Wood Studs or Steel Studs; 2007 (Reapproved 2013).
- G. ASTM C1047 - Standard Specification for Accessories for Gypsum Wallboard and Gypsum Veneer Base; 2010a.
- H. ASTM C1178/C1178M - Standard Specification for Coated Glass Mat Water-Resistant Gypsum Backing Panel; 2013.
- I. ASTM C1396/C1396M - Standard Specification for Gypsum Board; 2014.
- J. ASTM D3273 - Standard Test Method for Resistance to Growth of Mold on the Surface of Interior Coatings in an Environmental Chamber; 2012.
- K. ASTM E90 - Standard Test Method for Laboratory Measurement of Airborne Sound Transmission Loss of Building Partitions and Elements; 2009.
- L. ASTM E413 - Classification for Rating Sound Insulation; 2010.
- M. GA-216 - Application and Finishing of Gypsum Board; Gypsum Association; 2013.
- N. GA-600 - Fire Resistance Design Manual; Gypsum Association; 2012.

1.03 SUBMITTALS

- A. Shop Drawings: Indicate special details associated with fireproofing and acoustic seals.
- B. Product Data: Provide data on metal framing, gypsum board, glass mat faced gypsum board, accessories, and joint finishing system.

1.04 QUALITY ASSURANCE

- A. Perform in accordance with ASTM C 754, ASTM C 840. Comply with requirements of GA-600 for fire-rated assemblies. Comply with more stringent recommendations of Northwest Wall and Ceiling Bureau (NWCB).
 - 1. Maintain one copy of standards at project site.
- B. Provide acoustically rated assemblies in compliance with listings for ratings indicated.

GYPSUM BOARD ASSEMBLIES

- C. Installer Qualifications: Company specializing in performing gypsum board application and finishing, with minimum 5 years of documented experience.

PART 2 PRODUCTS

2.01 GYPSUM BOARD ASSEMBLIES

- A. Provide completed assemblies complying with ASTM C840 and GA-216.
- B. Interior Partitions Indicated as Acoustic: Provide completed assemblies with the following characteristics:
1. Acoustic Attenuation: STC of 45-49 calculated in accordance with ASTM E413, based on tests conducted in accordance with ASTM E90.

2.02 METAL FRAMING MATERIALS

- A. Manufacturers - Metal Framing, Connectors, and Accessories: Member of SSMA or GA.
- B. Interior Non-Loadbearing Framing System Components: ASTM C 645; galvanized sheet steel, of size and properties necessary to comply with ASTM C 754 for the spacing indicated, with maximum deflection of wall framing of L/240 at 5 psf, except L/360 at 5 psf for ceramic tile.
1. Studs: "C" shaped with flat or formed webs with knurled faces.
 2. Runners: U shaped, sized to match studs.
 3. Ceiling Channels: C shaped.
- C. Ceiling Hangers: Type and size as specified in ASTM C754 for spacing required.
- D. Partition Head To Structure Connections: Provide track fastened to structure with legs of sufficient length to accommodate deflection, for friction fit of studs cut short and screwed to secondary deflection channel set inside but unattached to top track.

2.03 INTERIOR BOARD MATERIALS

- A. Manufacturers - Gypsum-Based Board:
1. American Gypsum: www.americangypsum.com.
 2. CertainTeed Corporation: www.certainteed.com.
 3. Georgia-Pacific Gypsum: www.gpgypsum.com.
 4. Lafarge North America Inc: www.lafargenorthamerica.com.
 5. National Gypsum Company: www.nationalgypsum.com.
 6. PABCO Gypsum: www.pabco gypsum.com.
 7. Temple-Inland Inc: www.templeinland.com.
 8. USG Corporation: www.usg.com.
- B. Gypsum Wallboard: Paper-faced gypsum panels as defined in ASTM C1396/C1396M; sizes to minimize joints in place; ends square cut.
1. Application: Use for vertical surfaces and ceilings, unless otherwise indicated.
 2. Thickness:
 - a. Vertical Surfaces: 5/8 inch.
 - b. Ceilings: 5/8 inch.
 - c. Multi-Layer Assemblies: Thicknesses as indicated on drawings.
 3. Paper-Faced Products:
 - a. American Gypsum; EagleRoc Regular Gypsum Wallboard and FireBloc Type X Gypsum Wallboard.
 - b. CertainTeed Corporation; ProRoc Brand Gypsum Board.
 - c. CertainTeed Corporation; ProRoc Brand Abuse Resistant Gypsum Board.
 - d. Georgia-Pacific Gypsum; ToughRock.
 - e. Lafarge North America Inc; Regular Drywall and Firecheck Type X and Type C.
 - f. National Gypsum Company; Gold Bond Brand Gypsum Wallboard.
 - g. Pacific Coast Building Products, Inc; PABCO Regular Gypsum Wallboard and PABCO Flame Curb.
 - h. Temple-Inland Inc; Gypsumboard.

GYP SUM BOARD ASSEMBLIES

- i. USG Corporation; Sheetrock Brand Gypsum Panels.
- 4. Glass Mat Faced Products:
 - a. Georgia-Pacific Gypsum; DensArmor Plus.
- C. Backing Board For Wet Areas:
 - 1. Application: Surfaces behind tile, wet areas as defined, and including shower surrounds, and shower ceilings.
 - 2. Mold Resistance: Score of 10, when tested in accordance with ASTM D3273.
 - 3. Glass Mat Faced Board: Coated glass mat water-resistant gypsum backing panel as defined in ASTM C1178/C1178M.
 - a. Products:
 - 1) Georgia-Pacific Gypsum; DensShield Tile Backer.
- D. Backing Board For Non-Wet Areas: Water-resistant gypsum backing board as defined in ASTM C1396/C1396M; sizes to minimum joints in place; ends square cut.
 - 1. Application: Vertical surfaces behind thinset tile, except in wet areas.
 - 2. Edges: Tapered.
- E. Ceiling Board: Special sag-resistant gypsum ceiling board as defined in ASTM C1396/C1396M; sizes to minimize joints in place; ends square cut.
 - 1. Application: Ceilings, unless otherwise indicated.
 - 2. Thickness: 1/2 inch.
 - 3. Edges: Tapered.
- F. Water-Resistant Gypsum Backing Board: ASTM C 1396/C 1396M; ends square cut.
 - 1. Application: Vertical surfaces behind thinset tile, except in wet areas.
 - 2. Core Type: Regular and Type X, as indicated.
 - 3. Thickness: 5/8 inch.
 - 4. Edges: Tapered.

2.04 ACCESSORIES

- A. Acoustic Insulation: ASTM C665; preformed glass fiber, friction fit type, unfaced.
 - 1. Green Guard label, although made without formaldehyde is preferred.
- B. Acoustic Insulation: Use unfaced thermal insulation; see Section 07 21 00.
- C. Acoustic Sealant: As specified in Section 07 90 05.
- D. Finishing Accessories: ASTM C1047, galvanized steel or rolled zinc, unless otherwise indicated.
 - 1. Types: As detailed or required for finished appearance.
 - 2. Special Shapes: In addition to conventional cornerbead and control joints, provide U-bead at exposed panel edges.
- E. Joint Materials: ASTM C475 and as recommended by gypsum board manufacturer for project conditions.
 - 1. Chemical hardening type compound at wet areas.
- F. Textured Finish Materials: Latex-based compound; plain.
- G. PVA Primer: Latex-based a with polyvinyl acetate binder, Low V.O.C., High-hide, Fast drying primer
 - 1. Seals unpainted finished textured drywall. Product promotes a uniform surface for final finish
- H. Screws for Attachment to Steel Members Less Than 0.03 inch In Thickness, to Wood Members, and to Gypsum Board: ASTM C1002; self-piercing tapping type.
- I. Screws for Attachment to Steel Members From 0.033 to 0.112 Inch in Thickness: ASTM C954; steel drill screws for application of gypsum board to loadbearing steel studs.
- J. Screws: ASTM C 1002; self-piercing tapping type, anticorrosive-coated at wet areas.
- K. Screws: ASTM C 954; steel drill screws for application of gypsum board to 40 mil and greater steel studs, anticorrosive-coated.

GYPSUM BOARD ASSEMBLIES

- L. Screws: Use stainless steel at fire treated or preservative treated wood.
- M. Backing and blocking see Section 06 10 00.

PART 3 EXECUTION

3.01 EXAMINATION

- A. Verify that project conditions are appropriate for work of this section to commence.

3.02 FRAMING INSTALLATION

- A. Metal Framing: Install in accordance with ASTM C754 and manufacturer's instructions.
- B. Suspended Ceilings and Soffits: Space framing and furring members as indicated.
 - 1. Level ceiling system to a tolerance of 1/1200.
 - 2. Laterally brace and vertically constrain entire suspension system.
- C. Studs: Space studs at 16 inches on center, unless indicated otherwise.
 - 1. Extend partition framing to structure where indicated and to ceiling in other locations.
 - 2. Partitions Terminating at Ceiling: Attach ceiling runner securely to ceiling track in accordance with manufacturer's instructions.
 - 3. Partitions Terminating at Structure: Attach extended leg top runner to structure, maintain clearance between top of studs and structure, and brace both flanges of studs with continuous bridging.
 - 4. Provide not less than 43 mil thick studs supporting wall cabinets and similar high wall loads. Refer to casework specification for design load.
 - 5. Provide not less than 54 mil thick studs supporting plumbing fixtures, counter tops and similar low wall-hanging loads. In addition to dead load, support 300 pound live load located anywhere on supported item.
- D. Openings: Reinforce openings as required for weight of doors or operable panels, using not less than double 33 mil studs at jambs.
- E. Furring for Fire Ratings: Install as required for fire resistance ratings indicated and to GA-600 requirements.
- F. Blocking: Install blocking for support of plumbing fixtures, toilet partitions, wall cabinets, wood frame openings, toilet accessories, hardware, and other items as indicated. Comply with Section 06 10 54 for wood blocking with kerf for flange return.
 - 1. Metal blocking (where approved): Continuous 6 inch 43 mil track with legs cut at supports.

3.03 BOARD INSTALLATION

- A. Comply with most stringent of NWCB, ASTM C 840, GA-216, and manufacturer's instructions. Install to minimize butt end joints, especially in highly visible locations.
- B. Fire-Rated Construction: Install gypsum board in strict compliance with requirements of assembly listing.
- C. Installation on Metal Framing: Use screws for attachment of all gypsum board.
- D. Air Barrier Seal: Continuously seal joint between gypsum board and top plate of exterior walls. Provide continuous perimeter sealant joint and sealant joint at all penetrations of upper most ceiling. Seal other joints and gaps to assure complete and continuous air seal.
 - 1. Refer to Section 07 27 00 for continuous air and weather barrier system.
 - 2. Refer to building section drawings for additional information.
- E. Attach gypsum board to resilient channels between framing members.
- F. Moisture Protection: Treat cut edges and holes in moisture resistant gypsum board and exterior gypsum soffit board with sealant.

3.04 INSTALLATION OF TRIM AND ACCESSORIES

- A. Control Joints: Place control joints consistent with lines of building spaces and as indicated.
- B. Corner Beads: Install at external corners, using longest practical lengths.

GYPSUM BOARD ASSEMBLIES

- C. Edge Trim: Install at locations where gypsum board abuts dissimilar materials and as indicated.

3.05 JOINT TREATMENT

- A. Finish gypsum board in accordance with levels defined in ASTM C840, as follows:
 - 1. Level 3: Walls to receive medium orange peel textured wall finish.
 - 2. Level 2: In utility areas, behind cabinetry, and on backing board to receive tile finish or at FRP finish.
 - 3. Level 1: Fire rated wall areas above finished ceilings, whether or not accessible in the completed construction.
- B. Finish gypsum board in accordance with ASTM C 840/NWCB Level 3 textured, except where otherwise indicated.
- C. Tape, fill, and sand exposed joints, edges, and corners to produce smooth surface ready to receive finishes.
 - 1. Feather coats of joint compound so that camber is maximum 1/32 inch.

3.06 TEXTURE FINISH

- A. Apply finish texture coating by means of spraying apparatus in accordance with manufacturer's instructions and to match approved sample.

3.07 TOLERANCES

- A. Maximum Variation of Finished Gypsum Board Surface from True Flatness: 1/8 inch in 10 feet in any direction.

END DOCUMENT

DIVISION 9 - NON-STRUCTURAL METAL FRAMING

PART 1 - GENERAL

1.1 RELATED DOCUMENTS

- A. Drawings and general provisions of the Contract, including General and Supplementary Conditions and Division 01 Specification Sections, apply to this Section.

1.2 SUMMARY

- A. Section Includes:
 - 1. Non-load-bearing steel framing systems for interior partitions.

1.3 ACTION SUBMITTALS

- A. Product Data: For each type of product.

1.4 INFORMATIONAL SUBMITTALS

- A. Product Certificates: For each type of code-compliance certification for studs and tracks.
- B. Evaluation Reports: For post-installed anchors and power-actuated fasteners, from ICC-ES or other qualified testing agency acceptable to authorities having jurisdiction.

1.5 QUALITY ASSURANCE

- A. Code-Compliance Certification of Studs and Tracks: Provide documentation that framing members are certified according to the product-certification program of the Certified Steel Stud Association, the Steel Framing Industry Association, or the Steel Stud Manufacturers Association.

PART 2 - PRODUCTS

2.1 FRAMING SYSTEMS

- A. Framing Members, General: Comply with ASTM C 754 for conditions indicated.

1. Steel Sheet Components: Comply with ASTM C 645 requirements for steel unless otherwise indicated.
 2. Protective Coating: Coating with equivalent corrosion resistance of ASTM A 653/A 653M, G40, hot-dip galvanized unless otherwise indicated.
- B. Studs and Tracks: ASTM C 645.
1. Steel Studs and Tracks:
 - a. Manufacturers: Subject to compliance with requirements, provide products by one of the following:
 - 1) CEMCO; California Expanded Metal Products Co.
 - 2) ClarkDietrich.
 - 3) Custom Stud.
 - 4) Jaimes Industries.
 - 5) MarinoWARE.
 - 6) MBA Building Supplies.
 - 7) MRI Steel Framing, LLC.
 - 8) Phillips Manufacturing Co.
 - 9) SCAFCO Steel Stud Company.
 - 10) Steel Construction Systems.
 - 11) Telling Industries.
 - 12) The Steel Network, Inc.
 - b. Minimum Base-Steel Thickness: 0.0179 inch (0.455 mm), unless noted otherwise.
 - c. Depth: 3-5/8 inches (92 mm), unless noted otherwise.
- C. Flat Strap and Backing Plate: Steel sheet for blocking and bracing in length and width indicated.
1. Manufacturers: Subject to compliance with requirements, provide products by one of the following:
 - a. ClarkDietrich.
 - b. MarinoWARE.
 - c. MRI Steel Framing, LLC.
 - d. SCAFCO Steel Stud Company.
 - e. Steel Construction Systems.
 2. Minimum Base-Steel Thickness: 0.0329 inch.
- D. Cold-Rolled Channel Bridging: Steel, 0.0538-inch minimum base-steel thickness, with minimum 1/2-inch- wide flanges.
1. Manufacturers: Subject to compliance with requirements, provide products by one of the following:

- a. ClarkDietrich.
 - b. MarinoWARE.
 - c. MRI Steel Framing, LLC.
 - d. SCAFCO Steel Stud Company.
 - e. Steel Construction Systems.
2. Depth: 1-1/2 inches.
 3. Clip Angle: Not less than 1-1/2 by 1-1/2 inches, 0.068-inch- thick, galvanized steel.

2.2 AUXILIARY MATERIALS

- A. General: Provide auxiliary materials that comply with referenced installation standards.
 1. Fasteners for Steel Framing: Of type, material, size, corrosion resistance, holding power, and other properties required to fasten steel members to substrates.
- B. Isolation Strip at Exterior Walls: Provide one of the following:
 1. Asphalt-Saturated Organic Felt: ASTM D 226/D 226M, Type I (No. 15 asphalt felt), nonperforated.
 2. Foam Gasket: Adhesive-backed, closed-cell vinyl foam strips that allow fastener penetration without foam displacement, 1/8-inch thick, in width to suit steel stud size.

PART 3 - EXECUTION

3.1 EXAMINATION

- A. Examine areas and substrates, with Installer present, and including welded hollow-metal frames, cast-in anchors, and structural framing, for compliance with requirements and other conditions affecting performance of the Work.
- B. Proceed with installation only after unsatisfactory conditions have been corrected.

3.2 INSTALLATION, GENERAL

- A. Installation Standard: ASTM C 754.
 1. Gypsum Board Assemblies: Also comply with requirements in ASTM C 840 that apply to framing installation.
- B. Install framing and accessories plumb, square, and true to line, with connections securely fastened.

- C. Install supplementary framing, and blocking to support fixtures, equipment services, heavy trim, grab bars, toilet accessories, furnishings, or similar construction.
- D. Install bracing at terminations in assemblies.
- E. Do not bridge building control and expansion joints with non-load-bearing steel framing members. Frame both sides of joints independently.

3.3 INSTALLING FRAMED ASSEMBLIES

- A. Install framing system components according to spacings indicated, but not greater than spacings required by referenced installation standards for assembly types.
 - 1. Single-Layer Application: 24 inches o.c. unless otherwise indicated.
- B. Where studs are installed directly against exterior masonry walls or dissimilar metals at exterior walls, install isolation strip between studs and exterior wall.
- C. Install studs so flanges within framing system point in same direction.
- D. Install tracks at floors and overhead supports. Extend framing full height to structural supports or substrates above suspended ceilings except where partitions are indicated to terminate at suspended ceilings. Continue framing around ducts that penetrate partitions above ceiling.
- E. Installation Tolerance: Install each framing member so fastening surfaces vary not more than 1/8 inch from the plane formed by faces of adjacent framing.

THERMAL INSULATION

1.02 REFERENCE STANDARDS

- A. ASTM E136 - Standard Test Method for Behavior of Materials in a Vertical Tube Furnace At 750 Degrees C; 2012.

1.03 SUBMITTALS

- A. Product Data: Provide data on product characteristics, performance criteria, and product limitations.
- B. Manufacturer's Installation Instructions: Include information on special environmental conditions required for installation and installation techniques.
- C. Manufacturer's Certificate: Certify that products meet or exceed specified requirements.

1.04 FIELD CONDITIONS

- A. Do not install insulation adhesives when temperature or weather conditions are detrimental to successful installation.

PART 2 PRODUCTS

2.01 BATT INSULATION MATERIALS

- A. Glass Fiber Batt Insulation: Flexible preformed batt or blanket, complying with ASTM C 655; friction fit.
 - 1. Combustibility: Non-combustible, when tested in accordance with ASTM E136, except for facing, if any.
 - 2. Formaldehyde Content: Zero.
 - 3. Thermal Resistance: R of 3.6 per inch.
 - 4. Facing: Unfaced. at acoustical insulation applications.
 - 5. Facing: Aluminum foil, one side for furred exterior wall cavity locations.

2.02 SPRAY FOAM INSULATION

- A. Insulating Foam Sealant:
 - 1. Design Basis: Great Stuff by Dow.
 - a. Use product with appropriate expansion qualities around exterior envelope openings to ensure expansion does not displace opening components in a way that impedes installation of opening components, or operation of installed components.
 - 2. Locations: Between building opening components and wall cavity, voids at interfacing envelope components to provide continuous continuity of building thermal envelope.

2.03 FOAMED-IN-PLACE INSULATION

- A. Foamed-In-Place Insulation:
 - 1. Design Basis: See Section 07 21 19.

2.04 ACCESSORIES

- A. Tape: Bright aluminum self-adhering type, mesh reinforced, 2 inch wide.
- B. Adhesive: Type recommended by insulation manufacturer for application.
- C. Mesh Insulation Netting: 1 x 2 inch mesh netting size.
 - 1. Fasteners: Appropriate for purpose intended and approved for netting applications.

PART 3 EXECUTION 3.01
BATT INSTALLATION

THERMAL INSULATION

- A. Install insulation and vapor retarder in accordance with manufacturer's instructions.
- B. Install in exterior wall and roof spaces without gaps or voids. Do not compress insulation.
- C. Trim insulation neatly to fit spaces. Insulate miscellaneous gaps and voids.
- D. Fit insulation tightly in cavities and tightly to exterior side of mechanical and electrical services within the plane of the insulation.

END OF SECTION

NON-LOAD BEARING WALL FRAMING SYSTEMS

PART 1 - GENERAL

1.01 RELATED DOCUMENTS

- A. Drawings and General Provisions of Contract, including General Conditions and other Division 1 Specification Sections, shall apply to this Section.

1.02 REFERENCE STANDARDS

- A. ASTM A653 - Steel Sheet, Zinc-Coated (Galvanized) by the Hot-Dip Process, Structural (Physical) Quality.
- B. ASTM A1003 - Standard Specification for Steel Sheet, Carbon, Metallic- and Nonmetallic-Coated for Cold-Formed Framing Members.
- C. ASTM C645 - Standard Specification for Nonstructural Steel Framing Members.
- D. "Gypsum Construction Handbook" as published by United States Gypsum Company or "SFIA's Technical Guide for Cold-Formed Steel Framing Products" or a comparable manual as published by other acceptable manufacturer.

1.03 SUBMITTALS

- A. Materials Lists: Complete list of materials proposed to be furnished and installed, stating manufacturer's name and catalog number for each item.
- B. Product Data: For each product type.
- C. Manufacturer's Recommendations: Current recommended method of installation for each item. Recommendations shall be the basis for acceptance or rejection of actual installation methods used.

1.04 PRODUCT DELIVERY, STORAGE AND HANDLING

- A. Protection: Use means necessary to protect metal products from rusting and damage before, during and after installation and to protect the installed work and materials of other sections.
- B. Replacement: In event of damage, immediately make repairs and replacements necessary.
- C. Protect cold-formed metal framing from corrosion, deformation, and other damage during delivery, storage, and handling as required by AISI's "Code of Standard Practice".

NON-LOAD BEARING WALL FRAMING SYSTEMS

1.05 REQUIREMENTS OF REGULATORY AGENCIES

- A. Where fire-resistance classification is specified for walls or partitions with steel stud framing, provide steel studs and accessories of the type, which have been tested and listed for construction indicated.

PART 2 - PRODUCTS

2.01 ACCEPTABLE MANUFACTURERS

- A. ClarkDietrich Building Systems (basis of specification), West Chester, OH (www.clarkdietrich.com).
- B. Directly comparable products of the following manufacturers:
 - 1. MBA Building Supplies, Inc. Frackville, PA 17931 (www.mbastuds.com)
 - 2. [Southeastern](http://www.sestud.com) Stud & Components, Inc., Montgomery, AL (www.sestud.com)
- C. Other manufacturers, pre-bid approved in accordance with Section 01630, shall be acceptable.

2.02 MATERIALS

- A. General: Items specified are products of ClarkDietrich Building Systems. All studs shall be fabricated from steel having 33KSI minimum yield strength or better.
- B. Protective Coating: Comply with ASTM C 645; roll-formed from hot-dipped galvanized steel; complying with ASTM A 1003/A 1003M and ASTM A 653/A 653M G40 (Z120) or having a coating that provides equivalent corrosion resistance. A40 galvanized products are not acceptable.
- C. Metal Studs: ClarkDietrich ProSTUD 20 (20 gauge) with 1-1/4" flange; thickness as indicated on Drawings; 16" o. c. unless denoted otherwise on Drawings.
- D. Ceiling and Floor Runner: ClarkDietrich ProTRAK to match studs with 1-1/4" flange.
- E. Furring Channels: ClarkDietrich metal furring channel, 25 gauge; 7/8" x 2-23/32".
- F. Metal Angle Runners: 24 gauge.
- G. Cold Rolled Channels: ClarkDietrich cold rolled channels, 16 gauge; 3/4" and/or 1-1/2" as required.

NON-LOAD BEARING WALL FRAMING SYSTEMS

- H. All studs and accessories to be galvanized.
- I. Suspended Ceiling Grillage for Gypsum Board Ceilings:
 - 1. 8 gauge hanger wires at 48" o. c.
 - 2. 1-1/2" channels at 48" o. c.
 - 3. Metal furring channels at 16" o. c. anchored to 1-1/2" channels.
 - 4. Shall be in compliance with recommendations of USG's "Gypsum Construction Handbook."
- J. Backing Plate: Proprietary fire-resistance-treated blocking and bracing in width indicated.
 - 1. Product: Subject to compliance with requirements, provide ClarkDietrich Building Systems; Danback Fire-Treated Wood Backing Plate [D16F] [D24F], or a comparable product.
- K. Deflection Track: Steel sheet top runner manufactured to prevent cracking of finishes applied to interior partition framing resulting from deflection of structure above; in thickness not less than indicated for studs and in width to accommodate depth of studs.
 - 1. Product: Subject to compliance with design requirements provide ClarkDietrich Building Systems; [BlazeFrame DSL] [MaxTrak] [SLP-TRK] Slotted Deflection Track, or a comparable product.

2.03 FASTENERS

- A. Runner fasteners, power-driven type, to withstand 193 pounds single shear and 200 pounds bearing force when driven through structural head or base and without exceeding allowable design stress in runner, fastener or structural support.
- B. Screws: Pan self-drilling, self-tapping of size recommended by manufacturer for type of construction involved. See "Selector Guide for USG Screws" as printed in USG "Gypsum Construction Handbook."

2.04 AUXILIARY MATERIALS

- A. Isolation Strips at exterior walls: Provide one of the following:
 - 1. Asphalt-Saturated Organic Felt; ASTM D 226, Type I (No. 15 asphalt felt) nonperforated.

NON-LOAD BEARING WALL FRAMING SYSTEMS

2. Foam Gasket: Adhesive-backed, closed-cell vinyl foam strips that allow fastener penetration without foam displacement, 1/8" (3.2 mm) thick, in width to suit steel stud size.

PART 3 - EXECUTION

3.01 INSPECTION

- A. Prior to work, carefully inspect installed work and verify work is complete to point where installation may commence.
- B. Verify that metal studs may be installed in accordance with original design and manufacturer's recommendations.
- C. In event of discrepancies, immediately notify Owner's Representative and Architect. Do not proceed with installation until discrepancies have been fully resolved.

3.02 PREPARATION

- A. Accurately lay out partitions and wall lines from dimensions given.

3.03 INSTALLATION

- A. Install metal studs and accessory items in accordance with manufacturer's instructions, anchoring member's securely in position.
- B. Align partitions and wall assemblies to a tolerance of 1/8 inch in 8 feet, maximum variation from plumb or level in exposed line or surface.
- C. Securely fasten floor and ceiling runners 24 inches o. c. with suitable fasteners or to suspended ceiling at 16 inches o. c.
- D. Installation, Standard Metal Studs: ASTM C 754.
 1. Position vertically in the runners, spaced 16 inches o. c.
 2. Anchor studs located adjacent to door frames, partition intersections and corners to runner flanges by positive screw engagement with panhead screws through each stud flange and runner flange.
 3. Splice, when necessary, by nesting two studs with a minimum lap of 8 inches and attaching flanges together with two screws in each flange.
 4. Locate studs not more than 2 inches from doorframe jambs, abutting partitions, partition corners and other construction.

NON-LOAD BEARING WALL FRAMING SYSTEMS

5. Securely anchor to jamb and head anchor clips of each doorframe by bolt or screw attachment.
 6. Over metal door frames install a cut-to-length section of runner with flanges slit and web bent to allow flanges to overlap adjacent vertical studs and securely screw-attach to adjacent studs.
 7. Position a cut-to-length stud extending from doorframe header to ceiling runner at the vertical joint over the doorframe.
 8. When partitions abut an exterior wall, place an additional stud no greater than 6 in. from abutment.
 9. Extend and brace partitions to structure above ceiling as required and indicated on drawings.
 10. Install additional studs, blocking and/or headers to framing as necessary to provide for secure rigid attachment for doors, cabinets, fixtures and accessories.
 11. Reinforce partitions to support grab bars adequately for resisting 300 pounds shear. Install additional studs and/or blocking as necessary.
 12. Install continuous isolation strips at all exterior wall and metal framing junctures to fully isolate metal from contact with exterior wall construction.
- E. Isolation of Partitions from Structure: Where partitions abut ceiling or deck construction or vertical structural elements, provide slip or cushion-type joint between partition and structure as recommended by stud manufacturer to prevent the transfer of structural loads or movements to partitions.
- F. Extend partition framing full height to structural supports or framing above suspended ceilings, unless partitions are indicated to terminate at suspended ceilings.

END OF SECTION

GYPSUM WALLBOARD

PART 1 - GENERAL

1.01 RELATED DOCUMENTS

- A. Drawings and General Provisions of Contract, including General Conditions and other Division 1 Specification Sections, apply to the Work of this Section.

1.02 RELATED WORK

- A. Section 09110: Non-Load Bearing Wall Framing System.
- B. Refer to Section 09251 for abuse-resistant gypsum wall board.
- C. Refer to Section 09252 for High impact gypsum wall board.

1.03 REFERENCE STANDARDS

- A. ASTM C475 - Joint Treatment Materials for Gypsum Wallboard Construction.
- B. ASTM C 1396 - Standard Specification for Gypsum Board.
- C. ASTM E84 - Surface Burning Characteristics of Building Materials.
- D. ASTM E90 - Laboratory Measurement of Airborne-Sound Transmission Loss of Building Partitions.
- E. ASTM E119 - Fire Test of Building Construction and Materials.
- F. FS HH-1-521 - Insulation Blankets, Thermal (Mineral Fiber, for Ambient Temperatures).

1.04 CONSTRUCTION STANDARDS

- A. "Gypsum Construction Handbook" as published by United States Gypsum Co. or handbook of other approved manufacturer's; maintain one copy on job site.
- B. ASTM C840 - Application and Finishing of Gypsum Wallboard.

1.05 SUBMITTALS

- A. Submit the following:

GYPSUM WALLBOARD

1. Fire test reports where fire-rated gypsum wallboard assemblies are indicated on the Drawings.
2. Fire hazard classification of gypsum wallboard.
3. Certified test reports of other acceptable testing agencies that perform testing in accordance with ASTM E119, E84, and E90 are acceptable.
4. Manufacturer's specifications and printed installation instructions for each type of installation.
5. Provide GREENGUARD Certification as a low emitting material that meets CHPS requirements.
6. Provide Data for the weighted average recycled-content value both in postconsumer and secondary.

1.06 DELIVERY, STORAGE, AND HANDLING

- A. Coordinate delivery with installation to minimum storage periods at project site. Deliver in manufacturer's unopened bundles or packages, fully identified with manufacturer's name, brand, type and grade.
- B. Protect from weather, soiling and damage, using handling equipment and storage techniques recommended by the manufacturer.
- C. Store wallboard, trim and other accessories in a dry location, protected from weather and physical damage.

PART 2 - PRODUCTS

2.01 ACCEPTABLE MANUFACTURERS

- A. U.S. Gypsum Co. (Basis of Specification), Chicago, IL (www.usg.com).
- B. Products of the following manufacturers that meet or exceed the Specifications shall be acceptable:
 1. Temple-Inland Forest Products Corporation, Diboll, TX (www.templeinland.com).
 2. Gold Bond Building Products, National Gypsum Company, Charlotte, NC (www.nationalgypsum.com).
 3. Georgia Pacific, Corp., Atlanta, GA (www.gp.com).

GYPSUM WALLBOARD

4. Lafarge North America, Inc., Herndon, VA
(www.lafargenorthamerica.com).
5. CertainTeed, Valley Forge, PA (www.certainteed.com).
6. ClarkDietrich Building Systems, West Chester, OH
(www.clarkdietrich.com).

2.02 MATERIAL (Products of U. S. Gypsum Co. are specified below, except as noted)

A. Gypsum Board:

1. Regular Board: USG "Sheetrock" - 5/8" unless otherwise denoted on Drawings: Complies with ASTM C1396 and Fed. Spec. SS-L-30D, Type III, Grade "R", Class 1.
2. Fire Rated Board: USG Sheetrock Firecode "C" - 5/8" unless otherwise indicated on Drawings, at all fire rated construction: Complies with ASTM C1396 and Fed. Spec. SS-L-30D, Type III, Grade "X", Class 1.
3. Exterior Gypsum Ceiling Board: USG "Sheetrock" 5/8" thick with water repellent face paper surface; complies with ASTM C1396.
4. Gypsum Sheathing: "Gyp-Lap" sheathing, 5/8" thick with moisture resistant core and water repellent paper surfaces on face and back; complies with ASTM C1396.
5. Moisture-Resistant Board: Water resistant core; facing paper and back paper chemically treated to resist moisture penetration. Facing paper shall be light green color for identification. Complies with ASTM C1396.

B. Fasteners:

1. Screws: Self-drilling, self-tapping, bugle head, for use with power driver; minimum of Type S, 1 inch for single layer applications; 1-5/8 inch for two layer applications, in compliance with the recommendations of USG "Gypsum Construction Handbook."

C. Joint Treatment Materials:

1. Joint Tape: "Perf-A-Tape" perforated reinforcing tape.
2. Joint Compound: USG; ASTM C475, Ready-Mixed All Purpose Joint Compound.

D. Metal trim: (products of ClarkDietrich Building Systems)

1. ClarkDietrich 103 Deluxe Corner Bead.

GYPSUM WALLBOARD

2. ClarkDietrich 093 Zinc Control Joint.
 3. ClarkDietrich U-Trim M20A.
- E. Gasket:
1. Sponge neoprene strips as recommended by wallboard manufacturer, 75 maximum flame spread, ASTM E84.

PART 3 - EXECUTION

3.01 INSPECTION

- A. Check framing for accurate spacing and alignment to product surfaces within specified tolerances.
- B. Verify that spacing of installed framing does not exceed maximum allowable for thickness of drywall to be used.
- C. Verify that frames are set for thickness of drywall indicated.
- D. Do not proceed with installation of drywall until deficiencies are corrected and surfaces to receive drywall are acceptable.
 1. Repair protrusions of framing, twisted framing members, or unaligned members before installation of drywall is started.

3.02 INSTALLATION

- A. Install panels to a tolerance of 1/8 inch in 8 feet, maximum variation from plumb, or level in exposed line or surface, and with vertical joints on bearing.
- B. Use panels of maximum size practical lengths to minimize end butt joints. Where unavoidable, locate end butt joints as far from center of walls or ceilings as possible and stagger in alternate courses.
- C. Install gypsum drywall panel with face side out. Do not install imperfect, damaged, damp or wet panels. Butt panels together for a light contact at edges or ends with not more than 1/16 in. open space between panels. Do not force into place.
- D. Locate edges or end joints over supports except in horizontal applications or where intermediate supports or gypsum board backblocking is provided behind end joints. Position panels so that tapered edge joints abut and mill-cut or field-cut end joints abut. Do not place tapered edges against cut edges or ends. Stagger vertical joints over different studs on opposite sides of partition/walls.

GYPSUM WALLBOARD

- E. Provide additional framing and blocking as required to support gypsum drywall at openings and cutoffs.
- F. Accurately measure and precut gypsum drywall units prior to installation. Make cuts from face side by scoring and snapping away from face side or by sawing. Completely cut paper on back face; do not break paper by tearing. Maintain close tolerances for accurate fit at joints between sheets and at framed openings and to allow for covering of edges of cutouts with plates and escutcheons. Cut edges smooth as required for neat and accurate fit.
- G. Power-drive screws with electric screwdriver. Set screw so that head provides a slight depression below surface of drywall without tearing face of paper.

3.03 METAL TRIM AND CORNER BEADS

- A. Carefully inspect Drawings and verify location of metal trim required.
- B. Install trim in accordance with the manufacturer's recommendations.

3.04 TAPING AND FINISHING

- A. Environmental conditions:
 - 1. Control heating and ventilating during finishing operations to ensure the maintenance of 55 degrees F. minimum temperature.
- B. First coat:
 - 1. Spread compound evenly over joints, using suitable tools designed for the purpose.
 - 2. Fill joint recesses and metal trim.
 - 3. Center the reinforcing tape on joint and press into fresh compound, wiping down with sufficient pressure to remove excess compound but leaving sufficient compound under the tape for proper bond.
 - 4. Feather edges and leave surface free from blisters and tape wrinkles.
 - 5. Apply compound to fastener recesses, leaving flush with adjacent surfaces.
 - 6. Fold reinforcing tape along centerline and apply to interior angles, following the same procedure as for joints.
- C. Second coat:
 - 1. Lightly sand dry compound with fine sandpaper to remove irregularities.

GYP SUM WALLBOARD

2. Apply a second coat of compound to joints, feathering approximately three inches beyond edges of tape.
 3. Apply second coat to fastener recesses; allow to dry.
- D. Third coat:
1. Lightly sand dry compound with fine sandpaper to remove all irregularities.
 2. Apply final skim coat, feathering out approximately two inches beyond second coat.
 3. Third coat fastener recesses and metal trim and interior angles; allow to dry.
- E. "Smooth" finish:
1. Carefully sand coat to uniformly smooth surface free from irregularities visible to unaided eye at distance of five feet.

3.05 CLEAN UP

- A. Do not allow accumulation of scraps and debris arising from work of this Section. Maintain the premises in a neat and orderly condition. In the event of spilling or splashing compound onto other surfaces, immediately remove spilled or splashed material and traces or residue.
- B. Remove all excess materials from the project area after completion of all work, and dispose of all materials legally. Do not leave any materials on the premises as "attic stock."

END OF SECTION

- KEYED NOTES**
1. REFER TO SHEET 310.00 FOR TYPICAL WALL DETAILS.
 2. REFER TO SHEET 310.00 FOR TYPICAL CORNER WALL DETAILS.
 3. ALL CROSS MEMBERS SHALL BE CAPABLE OF CARRYING THE DESIGN LOAD WITHOUT EXCEEDING THE ALLOWED DEFLECTION.
 4. ALL SPAN WIRING SHALL BE SECURED TO THE MAIN RUNNER AND BE WITHIN 2" OF THE MAIN RUNNER.
 5. ALL SPAN WIRING SHALL BE SPACED FROM ALL HORIZONTAL PIPING OR DUCT WORK THAT IS MORE THAN 18" FROM THE MAIN RUNNER.
 6. HANGER AND PRIMER WIRING ARE TO BE CLAMPED TO THE MAIN RUNNER.
 7. HANGER WIRING SHALL NOT ATTACH TO OR BE CONNECTED TO INTERFERING EQUIPMENT. SEE SPECIFIC NOTES FOR THE SEVERAL TYPES OF EQUIPMENT.
 8. ALL STRUCTURE ABOVE THE MAIN RUNNER SHALL BE CAPABLE OF CARRYING THE DESIGN LOAD WITHOUT EXCEEDING THE ALLOWED DEFLECTION.
 9. ALL STRUCTURE ABOVE THE MAIN RUNNER SHALL BE CAPABLE OF CARRYING THE DESIGN LOAD WITHOUT EXCEEDING THE ALLOWED DEFLECTION.
 10. ALL STRUCTURE ABOVE THE MAIN RUNNER SHALL BE CAPABLE OF CARRYING THE DESIGN LOAD WITHOUT EXCEEDING THE ALLOWED DEFLECTION.
 11. ALL STRUCTURE ABOVE THE MAIN RUNNER SHALL BE CAPABLE OF CARRYING THE DESIGN LOAD WITHOUT EXCEEDING THE ALLOWED DEFLECTION.
 12. THE STRUT SHALL BE VERTICAL AND SHALL NOT HAVE MORE THAN 1/4" OUT OF PLUMB.
 13. ALL STRUCTURE ABOVE THE MAIN RUNNER SHALL BE CAPABLE OF CARRYING THE DESIGN LOAD WITHOUT EXCEEDING THE ALLOWED DEFLECTION.
 14. REFER TO SHEET 310.00 FOR TYPICAL WALL DETAILS.
 15. REFER TO SHEET 310.00 FOR TYPICAL CORNER WALL DETAILS.
 16. REFER TO SHEET 310.00 FOR TYPICAL WALL DETAILS.
 17. REFER TO SHEET 310.00 FOR TYPICAL CORNER WALL DETAILS.
 18. REFER TO SHEET 310.00 FOR TYPICAL WALL DETAILS.
 19. REFER TO SHEET 310.00 FOR TYPICAL CORNER WALL DETAILS.
 20. REFER TO SHEET 310.00 FOR TYPICAL WALL DETAILS.
 21. REFER TO SHEET 310.00 FOR TYPICAL CORNER WALL DETAILS.
 22. REFER TO SHEET 310.00 FOR TYPICAL WALL DETAILS.
 23. REFER TO SHEET 310.00 FOR TYPICAL CORNER WALL DETAILS.
 24. REFER TO SHEET 310.00 FOR TYPICAL WALL DETAILS.
 25. REFER TO SHEET 310.00 FOR TYPICAL CORNER WALL DETAILS.
 26. REFER TO SHEET 310.00 FOR TYPICAL WALL DETAILS.
 27. REFER TO SHEET 310.00 FOR TYPICAL CORNER WALL DETAILS.
 28. REFER TO SHEET 310.00 FOR TYPICAL WALL DETAILS.
 29. REFER TO SHEET 310.00 FOR TYPICAL CORNER WALL DETAILS.
 30. REFER TO SHEET 310.00 FOR TYPICAL WALL DETAILS.
 31. REFER TO SHEET 310.00 FOR TYPICAL CORNER WALL DETAILS.
 32. REFER TO SHEET 310.00 FOR TYPICAL WALL DETAILS.
 33. REFER TO SHEET 310.00 FOR TYPICAL CORNER WALL DETAILS.
 34. REFER TO SHEET 310.00 FOR TYPICAL WALL DETAILS.
 35. REFER TO SHEET 310.00 FOR TYPICAL CORNER WALL DETAILS.
 36. REFER TO SHEET 310.00 FOR TYPICAL WALL DETAILS.
 37. REFER TO SHEET 310.00 FOR TYPICAL CORNER WALL DETAILS.
 38. REFER TO SHEET 310.00 FOR TYPICAL WALL DETAILS.
 39. REFER TO SHEET 310.00 FOR TYPICAL CORNER WALL DETAILS.
 40. REFER TO SHEET 310.00 FOR TYPICAL WALL DETAILS.
 41. REFER TO SHEET 310.00 FOR TYPICAL CORNER WALL DETAILS.
 42. REFER TO SHEET 310.00 FOR TYPICAL WALL DETAILS.
 43. REFER TO SHEET 310.00 FOR TYPICAL CORNER WALL DETAILS.
 44. REFER TO SHEET 310.00 FOR TYPICAL WALL DETAILS.
 45. REFER TO SHEET 310.00 FOR TYPICAL CORNER WALL DETAILS.
 46. REFER TO SHEET 310.00 FOR TYPICAL WALL DETAILS.
 47. REFER TO SHEET 310.00 FOR TYPICAL CORNER WALL DETAILS.
 48. REFER TO SHEET 310.00 FOR TYPICAL WALL DETAILS.
 49. REFER TO SHEET 310.00 FOR TYPICAL CORNER WALL DETAILS.
 50. REFER TO SHEET 310.00 FOR TYPICAL WALL DETAILS.
 51. REFER TO SHEET 310.00 FOR TYPICAL CORNER WALL DETAILS.
 52. REFER TO SHEET 310.00 FOR TYPICAL WALL DETAILS.
 53. REFER TO SHEET 310.00 FOR TYPICAL CORNER WALL DETAILS.
 54. REFER TO SHEET 310.00 FOR TYPICAL WALL DETAILS.
 55. REFER TO SHEET 310.00 FOR TYPICAL CORNER WALL DETAILS.
 56. REFER TO SHEET 310.00 FOR TYPICAL WALL DETAILS.
 57. REFER TO SHEET 310.00 FOR TYPICAL CORNER WALL DETAILS.
 58. REFER TO SHEET 310.00 FOR TYPICAL WALL DETAILS.
 59. REFER TO SHEET 310.00 FOR TYPICAL CORNER WALL DETAILS.
 60. REFER TO SHEET 310.00 FOR TYPICAL WALL DETAILS.
 61. REFER TO SHEET 310.00 FOR TYPICAL CORNER WALL DETAILS.
 62. REFER TO SHEET 310.00 FOR TYPICAL WALL DETAILS.
 63. REFER TO SHEET 310.00 FOR TYPICAL CORNER WALL DETAILS.
 64. REFER TO SHEET 310.00 FOR TYPICAL WALL DETAILS.
 65. REFER TO SHEET 310.00 FOR TYPICAL CORNER WALL DETAILS.
 66. REFER TO SHEET 310.00 FOR TYPICAL WALL DETAILS.
 67. REFER TO SHEET 310.00 FOR TYPICAL CORNER WALL DETAILS.
 68. REFER TO SHEET 310.00 FOR TYPICAL WALL DETAILS.
 69. REFER TO SHEET 310.00 FOR TYPICAL CORNER WALL DETAILS.
 70. REFER TO SHEET 310.00 FOR TYPICAL WALL DETAILS.
 71. REFER TO SHEET 310.00 FOR TYPICAL CORNER WALL DETAILS.
 72. REFER TO SHEET 310.00 FOR TYPICAL WALL DETAILS.
 73. REFER TO SHEET 310.00 FOR TYPICAL CORNER WALL DETAILS.
 74. REFER TO SHEET 310.00 FOR TYPICAL WALL DETAILS.
 75. REFER TO SHEET 310.00 FOR TYPICAL CORNER WALL DETAILS.
 76. REFER TO SHEET 310.00 FOR TYPICAL WALL DETAILS.
 77. REFER TO SHEET 310.00 FOR TYPICAL CORNER WALL DETAILS.
 78. REFER TO SHEET 310.00 FOR TYPICAL WALL DETAILS.
 79. REFER TO SHEET 310.00 FOR TYPICAL CORNER WALL DETAILS.
 80. REFER TO SHEET 310.00 FOR TYPICAL WALL DETAILS.
 81. REFER TO SHEET 310.00 FOR TYPICAL CORNER WALL DETAILS.
 82. REFER TO SHEET 310.00 FOR TYPICAL WALL DETAILS.
 83. REFER TO SHEET 310.00 FOR TYPICAL CORNER WALL DETAILS.
 84. REFER TO SHEET 310.00 FOR TYPICAL WALL DETAILS.
 85. REFER TO SHEET 310.00 FOR TYPICAL CORNER WALL DETAILS.
 86. REFER TO SHEET 310.00 FOR TYPICAL WALL DETAILS.
 87. REFER TO SHEET 310.00 FOR TYPICAL CORNER WALL DETAILS.
 88. REFER TO SHEET 310.00 FOR TYPICAL WALL DETAILS.
 89. REFER TO SHEET 310.00 FOR TYPICAL CORNER WALL DETAILS.
 90. REFER TO SHEET 310.00 FOR TYPICAL WALL DETAILS.
 91. REFER TO SHEET 310.00 FOR TYPICAL CORNER WALL DETAILS.
 92. REFER TO SHEET 310.00 FOR TYPICAL WALL DETAILS.
 93. REFER TO SHEET 310.00 FOR TYPICAL CORNER WALL DETAILS.
 94. REFER TO SHEET 310.00 FOR TYPICAL WALL DETAILS.
 95. REFER TO SHEET 310.00 FOR TYPICAL CORNER WALL DETAILS.
 96. REFER TO SHEET 310.00 FOR TYPICAL WALL DETAILS.
 97. REFER TO SHEET 310.00 FOR TYPICAL CORNER WALL DETAILS.
 98. REFER TO SHEET 310.00 FOR TYPICAL WALL DETAILS.
 99. REFER TO SHEET 310.00 FOR TYPICAL CORNER WALL DETAILS.
 100. REFER TO SHEET 310.00 FOR TYPICAL WALL DETAILS.

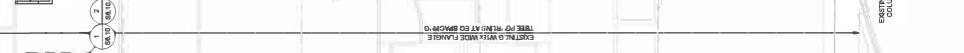
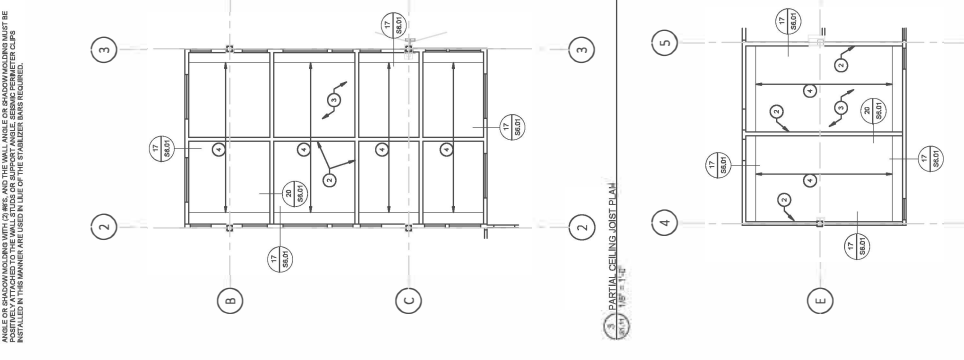

- KEYED NOTES**
1. UNLESS OTHERWISE NOTED, ALL MATERIALS SHALL BE USED IN ACCORDANCE WITH THE 2024 IBC AND 2024 IRC.
 2. ALL DIMENSIONS SHALL BE TO FACE UNLESS OTHERWISE NOTED.
 3. UNLESS OTHERWISE NOTED, ALL WALLS SHALL BE CONCRETE BLOCK WITH EXTERIOR FINISH AND INTERIOR FINISH.
 4. UNLESS OTHERWISE NOTED, ALL ROOFING SHALL BE ASPH/FLT SHINGLES WITH 1/2" Gypsum Board on top.
 5. UNLESS OTHERWISE NOTED, ALL ROOFING SHALL BE 1/2" Gypsum Board on top.
 6. UNLESS OTHERWISE NOTED, ALL ROOFING SHALL BE 1/2" Gypsum Board on top.
 7. UNLESS OTHERWISE NOTED, ALL ROOFING SHALL BE 1/2" Gypsum Board on top.
 8. UNLESS OTHERWISE NOTED, ALL ROOFING SHALL BE 1/2" Gypsum Board on top.
 9. UNLESS OTHERWISE NOTED, ALL ROOFING SHALL BE 1/2" Gypsum Board on top.
 10. UNLESS OTHERWISE NOTED, ALL ROOFING SHALL BE 1/2" Gypsum Board on top.
 11. UNLESS OTHERWISE NOTED, ALL ROOFING SHALL BE 1/2" Gypsum Board on top.
 12. UNLESS OTHERWISE NOTED, ALL ROOFING SHALL BE 1/2" Gypsum Board on top.
 13. UNLESS OTHERWISE NOTED, ALL ROOFING SHALL BE 1/2" Gypsum Board on top.
 14. UNLESS OTHERWISE NOTED, ALL ROOFING SHALL BE 1/2" Gypsum Board on top.
 15. UNLESS OTHERWISE NOTED, ALL ROOFING SHALL BE 1/2" Gypsum Board on top.
 16. UNLESS OTHERWISE NOTED, ALL ROOFING SHALL BE 1/2" Gypsum Board on top.
 17. UNLESS OTHERWISE NOTED, ALL ROOFING SHALL BE 1/2" Gypsum Board on top.
 18. UNLESS OTHERWISE NOTED, ALL ROOFING SHALL BE 1/2" Gypsum Board on top.
 19. UNLESS OTHERWISE NOTED, ALL ROOFING SHALL BE 1/2" Gypsum Board on top.
 20. UNLESS OTHERWISE NOTED, ALL ROOFING SHALL BE 1/2" Gypsum Board on top.
 21. UNLESS OTHERWISE NOTED, ALL ROOFING SHALL BE 1/2" Gypsum Board on top.
 22. UNLESS OTHERWISE NOTED, ALL ROOFING SHALL BE 1/2" Gypsum Board on top.
 23. UNLESS OTHERWISE NOTED, ALL ROOFING SHALL BE 1/2" Gypsum Board on top.
 24. UNLESS OTHERWISE NOTED, ALL ROOFING SHALL BE 1/2" Gypsum Board on top.
 25. UNLESS OTHERWISE NOTED, ALL ROOFING SHALL BE 1/2" Gypsum Board on top.
 26. UNLESS OTHERWISE NOTED, ALL ROOFING SHALL BE 1/2" Gypsum Board on top.
 27. UNLESS OTHERWISE NOTED, ALL ROOFING SHALL BE 1/2" Gypsum Board on top.
 28. UNLESS OTHERWISE NOTED, ALL ROOFING SHALL BE 1/2" Gypsum Board on top.
 29. UNLESS OTHERWISE NOTED, ALL ROOFING SHALL BE 1/2" Gypsum Board on top.
 30. UNLESS OTHERWISE NOTED, ALL ROOFING SHALL BE 1/2" Gypsum Board on top.
 31. UNLESS OTHERWISE NOTED, ALL ROOFING SHALL BE 1/2" Gypsum Board on top.
 32. UNLESS OTHERWISE NOTED, ALL ROOFING SHALL BE 1/2" Gypsum Board on top.
 33. UNLESS OTHERWISE NOTED, ALL ROOFING SHALL BE 1/2" Gypsum Board on top.
 34. UNLESS OTHERWISE NOTED, ALL ROOFING SHALL BE 1/2" Gypsum Board on top.
 35. UNLESS OTHERWISE NOTED, ALL ROOFING SHALL BE 1/2" Gypsum Board on top.
 36. UNLESS OTHERWISE NOTED, ALL ROOFING SHALL BE 1/2" Gypsum Board on top.
 37. UNLESS OTHERWISE NOTED, ALL ROOFING SHALL BE 1/2" Gypsum Board on top.
 38. UNLESS OTHERWISE NOTED, ALL ROOFING SHALL BE 1/2" Gypsum Board on top.
 39. UNLESS OTHERWISE NOTED, ALL ROOFING SHALL BE 1/2" Gypsum Board on top.
 40. UNLESS OTHERWISE NOTED, ALL ROOFING SHALL BE 1/2" Gypsum Board on top.
 41. UNLESS OTHERWISE NOTED, ALL ROOFING SHALL BE 1/2" Gypsum Board on top.
 42. UNLESS OTHERWISE NOTED, ALL ROOFING SHALL BE 1/2" Gypsum Board on top.
 43. UNLESS OTHERWISE NOTED, ALL ROOFING SHALL BE 1/2" Gypsum Board on top.
 44. UNLESS OTHERWISE NOTED, ALL ROOFING SHALL BE 1/2" Gypsum Board on top.
 45. UNLESS OTHERWISE NOTED, ALL ROOFING SHALL BE 1/2" Gypsum Board on top.
 46. UNLESS OTHERWISE NOTED, ALL ROOFING SHALL BE 1/2" Gypsum Board on top.
 47. UNLESS OTHERWISE NOTED, ALL ROOFING SHALL BE 1/2" Gypsum Board on top.
 48. UNLESS OTHERWISE NOTED, ALL ROOFING SHALL BE 1/2" Gypsum Board on top.
 49. UNLESS OTHERWISE NOTED, ALL ROOFING SHALL BE 1/2" Gypsum Board on top.
 50. UNLESS OTHERWISE NOTED, ALL ROOFING SHALL BE 1/2" Gypsum Board on top.
 51. UNLESS OTHERWISE NOTED, ALL ROOFING SHALL BE 1/2" Gypsum Board on top.
 52. UNLESS OTHERWISE NOTED, ALL ROOFING SHALL BE 1/2" Gypsum Board on top.
 53. UNLESS OTHERWISE NOTED, ALL ROOFING SHALL BE 1/2" Gypsum Board on top.
 54. UNLESS OTHERWISE NOTED, ALL ROOFING SHALL BE 1/2" Gypsum Board on top.
 55. UNLESS OTHERWISE NOTED, ALL ROOFING SHALL BE 1/2" Gypsum Board on top.
 56. UNLESS OTHERWISE NOTED, ALL ROOFING SHALL BE 1/2" Gypsum Board on top.
 57. UNLESS OTHERWISE NOTED, ALL ROOFING SHALL BE 1/2" Gypsum Board on top.
 58. UNLESS OTHERWISE NOTED, ALL ROOFING SHALL BE 1/2" Gypsum Board on top.
 59. UNLESS OTHERWISE NOTED, ALL ROOFING SHALL BE 1/2" Gypsum Board on top.
 60. UNLESS OTHERWISE NOTED, ALL ROOFING SHALL BE 1/2" Gypsum Board on top.
 61. UNLESS OTHERWISE NOTED, ALL ROOFING SHALL BE 1/2" Gypsum Board on top.
 62. UNLESS OTHERWISE NOTED, ALL ROOFING SHALL BE 1/2" Gypsum Board on top.
 63. UNLESS OTHERWISE NOTED, ALL ROOFING SHALL BE 1/2" Gypsum Board on top.
 64. UNLESS OTHERWISE NOTED, ALL ROOFING SHALL BE 1/2" Gypsum Board on top.
 65. UNLESS OTHERWISE NOTED, ALL ROOFING SHALL BE 1/2" Gypsum Board on top.
 66. UNLESS OTHERWISE NOTED, ALL ROOFING SHALL BE 1/2" Gypsum Board on top.
 67. UNLESS OTHERWISE NOTED, ALL ROOFING SHALL BE 1/2" Gypsum Board on top.
 68. UNLESS OTHERWISE NOTED, ALL ROOFING SHALL BE 1/2" Gypsum Board on top.
 69. UNLESS OTHERWISE NOTED, ALL ROOFING SHALL BE 1/2" Gypsum Board on top.
 70. UNLESS OTHERWISE NOTED, ALL ROOFING SHALL BE 1/2" Gypsum Board on top.
 71. UNLESS OTHERWISE NOTED, ALL ROOFING SHALL BE 1/2" Gypsum Board on top.
 72. UNLESS OTHERWISE NOTED, ALL ROOFING SHALL BE 1/2" Gypsum Board on top.
 73. UNLESS OTHERWISE NOTED, ALL ROOFING SHALL BE 1/2" Gypsum Board on top.
 74. UNLESS OTHERWISE NOTED, ALL ROOFING SHALL BE 1/2" Gypsum Board on top.
 75. UNLESS OTHERWISE NOTED, ALL ROOFING SHALL BE 1/2" Gypsum Board on top.
 76. UNLESS OTHERWISE NOTED, ALL ROOFING SHALL BE 1/2" Gypsum Board on top.
 77. UNLESS OTHERWISE NOTED, ALL ROOFING SHALL BE 1/2" Gypsum Board on top.
 78. UNLESS OTHERWISE NOTED, ALL ROOFING SHALL BE 1/2" Gypsum Board on top.
 79. UNLESS OTHERWISE NOTED, ALL ROOFING SHALL BE 1/2" Gypsum Board on top.
 80. UNLESS OTHERWISE NOTED, ALL ROOFING SHALL BE 1/2" Gypsum Board on top.
 81. UNLESS OTHERWISE NOTED, ALL ROOFING SHALL BE 1/2" Gypsum Board on top.
 82. UNLESS OTHERWISE NOTED, ALL ROOFING SHALL BE 1/2" Gypsum Board on top.
 83. UNLESS OTHERWISE NOTED, ALL ROOFING SHALL BE 1/2" Gypsum Board on top.
 84. UNLESS OTHERWISE NOTED, ALL ROOFING SHALL BE 1/2" Gypsum Board on top.
 85. UNLESS OTHERWISE NOTED, ALL ROOFING SHALL BE 1/2" Gypsum Board on top.
 86. UNLESS OTHERWISE NOTED, ALL ROOFING SHALL BE 1/2" Gypsum Board on top.
 87. UNLESS OTHERWISE NOTED, ALL ROOFING SHALL BE 1/2" Gypsum Board on top.
 88. UNLESS OTHERWISE NOTED, ALL ROOFING SHALL BE 1/2" Gypsum Board on top.
 89. UNLESS OTHERWISE NOTED, ALL ROOFING SHALL BE 1/2" Gypsum Board on top.
 90. UNLESS OTHERWISE NOTED, ALL ROOFING SHALL BE 1/2" Gypsum Board on top.
 91. UNLESS OTHERWISE NOTED, ALL ROOFING SHALL BE 1/2" Gypsum Board on top.
 92. UNLESS OTHERWISE NOTED, ALL ROOFING SHALL BE 1/2" Gypsum Board on top.
 93. UNLESS OTHERWISE NOTED, ALL ROOFING SHALL BE 1/2" Gypsum Board on top.
 94. UNLESS OTHERWISE NOTED, ALL ROOFING SHALL BE 1/2" Gypsum Board on top.
 95. UNLESS OTHERWISE NOTED, ALL ROOFING SHALL BE 1/2" Gypsum Board on top.
 96. UNLESS OTHERWISE NOTED, ALL ROOFING SHALL BE 1/2" Gypsum Board on top.
 97. UNLESS OTHERWISE NOTED, ALL ROOFING SHALL BE 1/2" Gypsum Board on top.
 98. UNLESS OTHERWISE NOTED, ALL ROOFING SHALL BE 1/2" Gypsum Board on top.
 99. UNLESS OTHERWISE NOTED, ALL ROOFING SHALL BE 1/2" Gypsum Board on top.
 100. UNLESS OTHERWISE NOTED, ALL ROOFING SHALL BE 1/2" Gypsum Board on top.

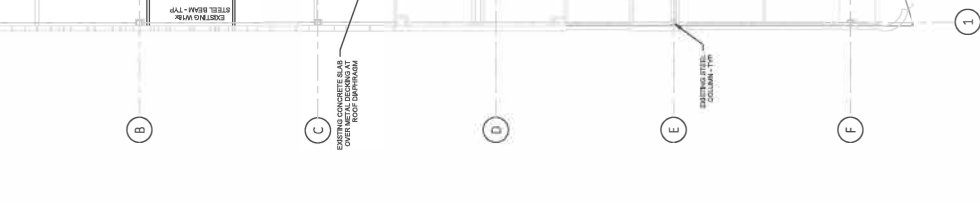
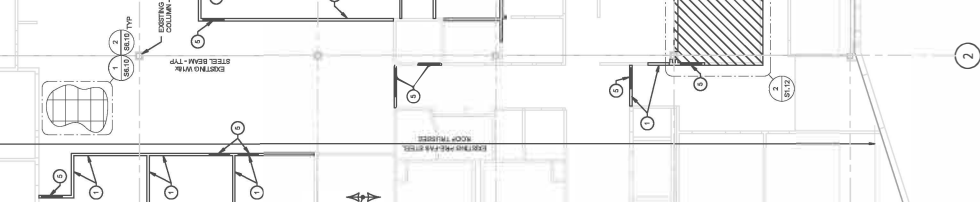
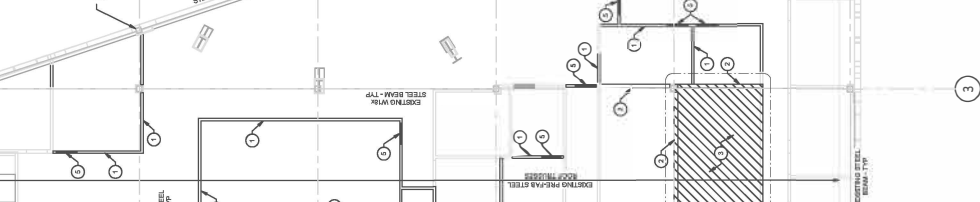
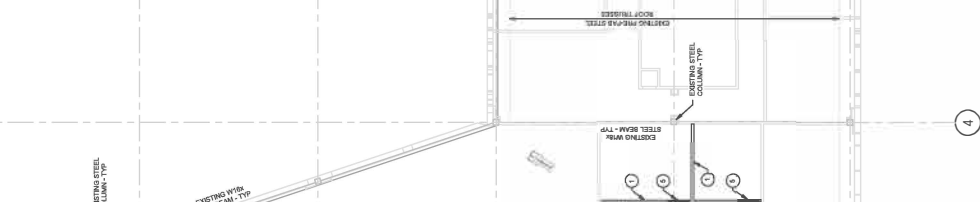

EXISTING ROOF FRAMING PLAN

EXISTING ROOF FRAMING PLAN

EXISTING ROOF FRAMING PLAN

EXISTING ROOF FRAMING PLAN

EXISTING ROOF FRAMING PLAN

EXISTING ROOF FRAMING PLAN

EXISTING ROOF FRAMING PLAN

EXISTING ROOF FRAMING PLAN

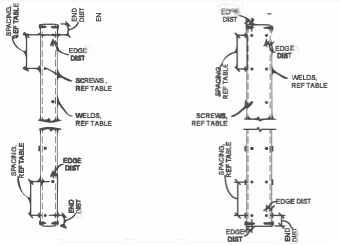

BUILT-UP MEMBER	FASTENER SIZE	FASTENER SPACING	FASTENER END DIST	FASTENER EDGE DIST	ROWS OF FASTENERS
(2) 4" STUDS	#10 SCREWS	8"	2.0"	1" 1.5"	1 - STAGGER
(4) 4" STUDS	#10 SCREWS + 1" LONG WELDS	8"	2.0"	1" 1.5"	1 - STAGGER
(2) 8" STUDS	#10 SCREWS	8"	2.0"	1" 1.5"	2
(4) 8" STUDS	#10 SCREWS + 1" LONG WELDS	8"	2.0"	1" 1.5"	2

NOTES:
 1. PLYWOOD SHEATHING OR GYP BOARD FASTENERS SHALL BE STAGGERED TO EACH STUD IN BUILT-UP MEMBER.
 2. SCREWS SHALL BE STAGGERED EACH SIDE OF BUILT-UP MEMBER.

4 BUILT-UP OFS POSTS
 1" = 1'-0"

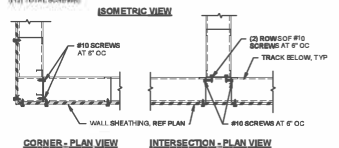
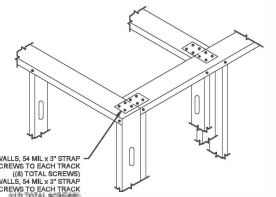

5 WALL FRAMING AT CORNERS AND INTERSECTIONS
 1" = 1'-0"

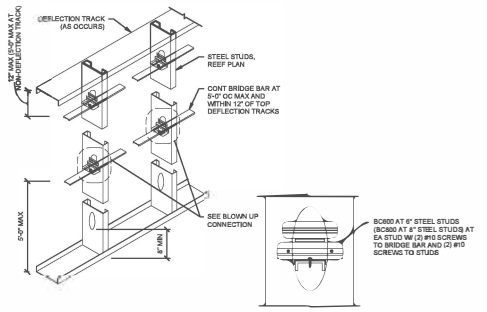

1 STEEL STUD WALL BRIDGING
 1" = 1'-0"

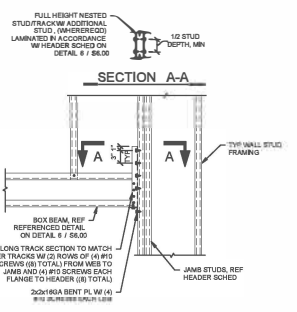

8 HEADER TO JAMB STUD
 1" = 1'-0"

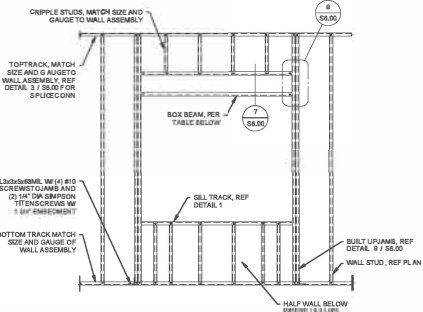

OPENING	5 1/2" WIDE BOXED	3 5/8" WIDE BOXED	JAMB STUD	FASTENERS	SEIL
0 TO 8'-0"	(2) 8005162-33 (2) 3021190-33 REF 7 / 58.00	(3) 8005162-33 (2) 3021190-33 REF 7 / 58.00	(2) 3021190-33 (USE (2) 3025162-43 STUDS AT 4" FROM WALLS	(2) #10 SCREWS TO EACH JAMB STUD (8) TOTAL SCREWS AT EACH END OF HEADER	5907125-43
8'-1" TO 10'-0"	(2) 8005162-43 (2) 3021190-43 REF 7 / 58.00	(2) 8005162-43 (2) 3021190-43 REF 7 / 58.00	(2) 3021190-43 (USE (2) 3025162-43 STUDS AT 4" FROM WALLS	(3) #10 SCREWS TO EACH JAMB STUD (12) TOTAL SCREWS AT EACH END OF HEADER	5907125-43
10'-1" TO 15'-0"	(2) 10005162-43 (2) 3021190-43 REF 7 / 58.00	(2) 10005162-43 (2) 3021190-43 REF 7 / 58.00	(2) 3021190-43 (USE (2) 3025200-54 STUDS AT 4" FROM WALLS	(4) #10 SCREWS TO EACH JAMB STUD (16) TOTAL SCREWS AT EACH END OF HEADER	5907150-64

NOTES:
 1. REFER TO STUD WALL SCHEDULE FOR STUD SIZES, SPACING AND GAUGES.
 2. REFERENCED DETAIL OR TYPICAL CONNECTIONS.

8 STEEL FRAMING AT WALL OPENING
 1" = 1'-0"

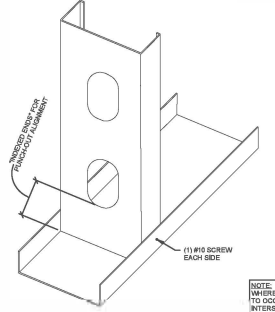

2 STUD TO TRACK ATTACHMENT
 1" = 1'-0"

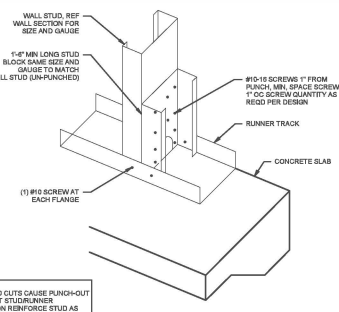

3 TOP TRACK SPLICE
 1" = 1'-0"

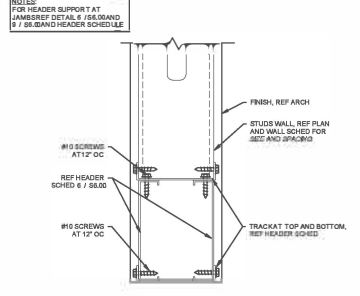

7 BOX HEADER DETAIL
 1" = 1'-0"

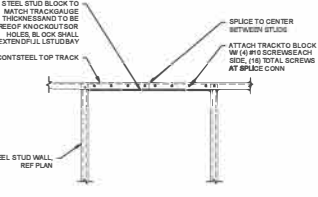

4 ALLOWABLE HOLES THRU STEEL TOP AND BOTTOM TRACK
 1" = 1'-0"



CLACKAMAS COUNTY BEHAVIORAL HEALTH CLIENT:
 CLACKAMAS COUNTY

PROJECT ADDRESS:
 6605 SE Lake Rd, Milwaukie, OR 97222

APPROVED	DATE	BY
NEWAY OCCUPANTS	11-25-2014	APRWAY

PROJECT NO.	2221-102
DATE:	11-25-2014
CLIENT:	CL
DESIGNER:	YC
© PINACLE ARCHITECTURE, INC. 2017 ORIGINAL SHEET NO. 207-047	

NON-STRUCTURAL WALL DETAILS

\$6.00

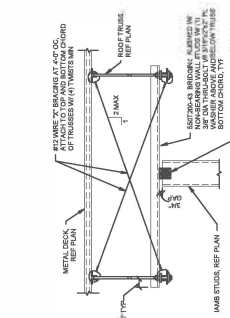

10. JAMB STUD CONNECTION AT TOP
1/4" = 1'-0"

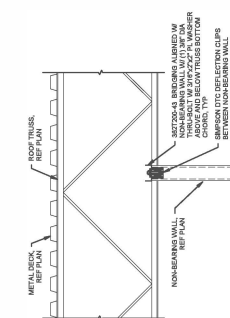

15. NON-BEARING WALL CONNECTION AT TOP
1/4" = 1'-0"

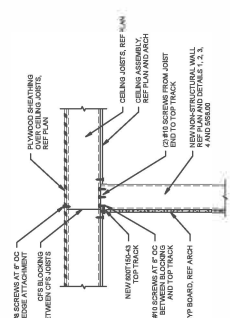

17. NEW CEILING JOIST CONNECTION TO NEW 2\"/>

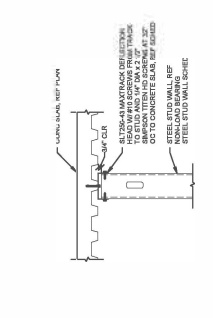

11. NON-BEARING WALL CONNECTION AT TOP TO CONCRETE SLAB
1/4" = 1'-0"

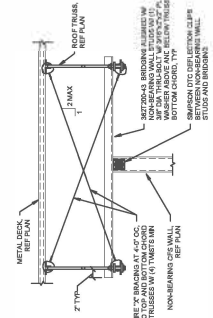

16. NON-BEARING WALL CONNECTION AT TOP
1/4" = 1'-0"

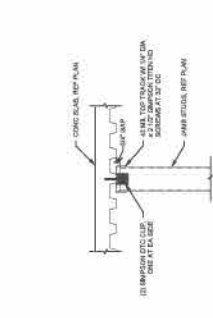

12. JAMB STUD CONNECTION AT TOP TO CONCRETE SLAB
1/4" = 1'-0"

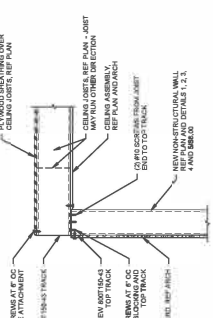

18. NEW CEILING JOIST CONNECTION TO NEW 2\"/>

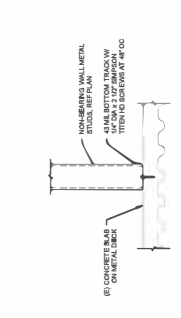

13. NON-BEARING WALL CONNECTION AT BOTTOM TO CONCRETE SLAB
1/4" = 1'-0"

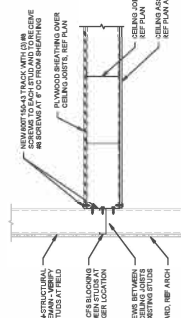

14. WINDOW SILL TO JAMB STUD
1/4" = 1'-0"



15. NON-BEARING WALL CONNECTION AT TOP
1/4" = 1'-0"

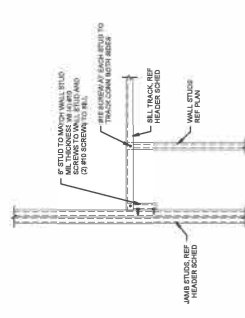

13. NON-BEARING WALL CONNECTION AT BOTTOM TO CONCRETE SLAB
1/4" = 1'-0"

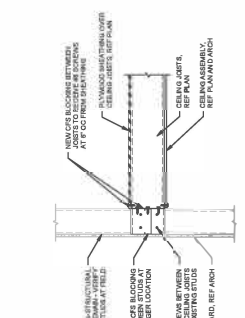

14. WINDOW SILL TO JAMB STUD
1/4" = 1'-0"

NOTES:

1. VERIFY FINISHES AND SHOW FOR CLARITY. REF. ARCH.
2. VERIFY FINISHES AND SHOW FOR CLARITY. REF. ARCH.
3. VERIFY FINISHES AND SHOW FOR CLARITY. REF. ARCH.
4. VERIFY FINISHES AND SHOW FOR CLARITY. REF. ARCH.

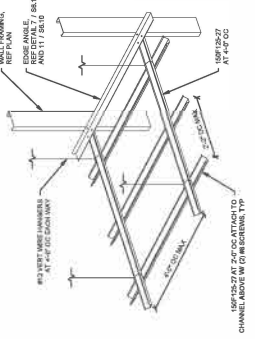

1. SUSPENDED SOFFIT FRAMING TYP.
1/4\"/>

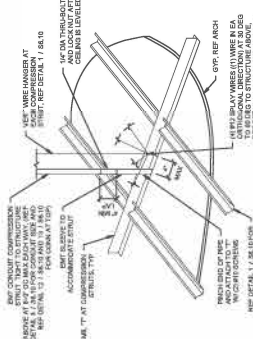

2. SUSPENDED SOFFIT LATERAL BRACING TYP.
1/4\"/>

EMT CONDUIT COMPRESSION

MAX LENGTH	EMT PIPE STRUT
3'-0"	1/2" DIA EMT CONDUIT
6'-0"	1" DIA EMT CONDUIT
8'-0"	2" DIA EMT CONDUIT

NOTES:

1. EMT CONDUIT TO BE MANUFACTURED BY [Manufacturer].
2. EMT CONDUIT TO BE SCHEDULE 40.
3. EMT CONDUIT TO BE SCHEDULE 40.
4. EMT CONDUIT TO BE SCHEDULE 40.

3. COMPRESSION PIPE STRUT SCHEDULE
1/4\"/>

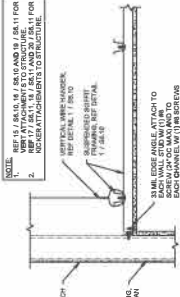

4. SUSPENDED SOFFIT EDGE CONDITION
1/4\"/>

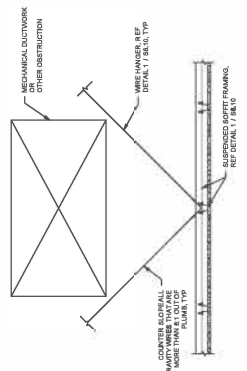

5. SUSPENDED SOFFIT VERTICAL WIRE HANGER OBSTRUCTION
1/4\"/>

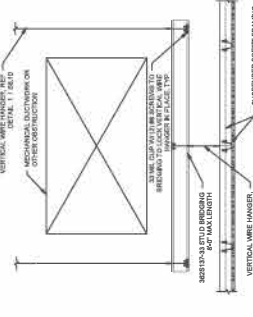

6. SUSPENDED SOFFIT VERTICAL WIRE HANGER OBSTRUCTION
1/4\"/>

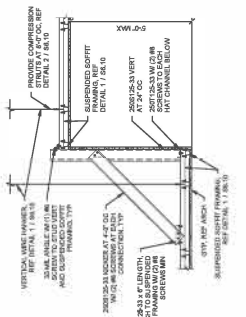

7. SUSPENDED SOFFIT FRAMING STEP TYP.
1/4\"/>

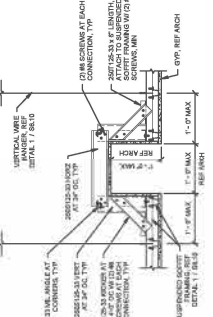

8. SUSPENDED SOFFIT FRAMING AT COVE LIGHT
1/4\"/>

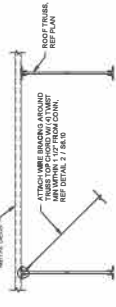

9. SUSPENDED SOFFIT WIRE BRACING TO STRUCTURE
1/4\"/>

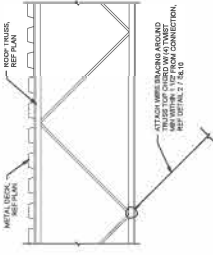

10. SUSPENDED SOFFIT WIRE BRACING TO STRUCTURE
1/4\"/>

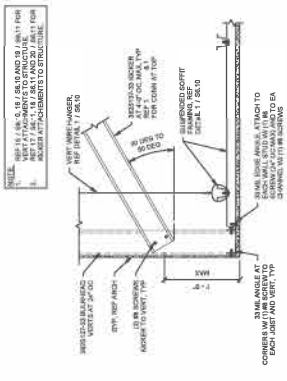

11. SUSPENDED SOFFIT BULKHEAD
1/4\"/>

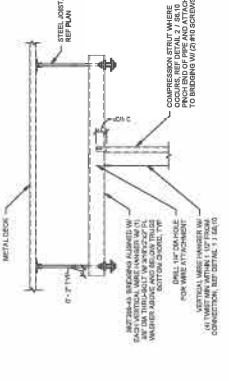

12. SUSPENDED SOFFIT VERTICAL WIRE TO STRUCTURE
1/4\"/>

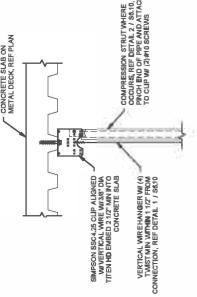

13. SUSPENDED SOFFIT VERTICAL WIRE TO STRUCTURE
1/4\"/>

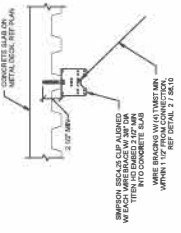

14. SUSPENDED SOFFIT WIRE BRACING TO STRUCTURE
1/4\"/>

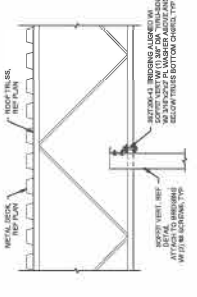

15. SUSPENDED SOFFIT BULKHEAD VERT TO STRUCTURE
1/4\"/>

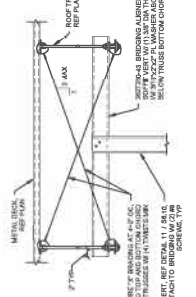

16. SUSPENDED SOFFIT BULKHEAD VERT TO STRUCTURE
1/4\"/>

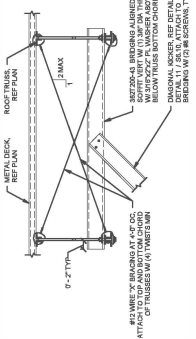

17 SOFFIT KICKER TO STRUCTURE
SCALE: 1/4" = 1'-0"

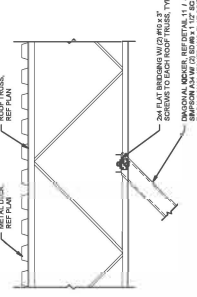

18 SOFFIT KICKER TO STRUCTURE
SCALE: 1/4" = 1'-0"

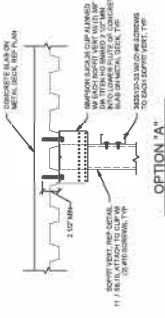

19 SUSPENDED SOFFIT BULKHEAD VERT TO STRUCTURE
SCALE: 1/4" = 1'-0"

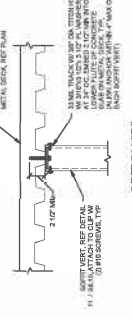

20 SUSPENDED SOFFIT BULKHEAD VERT TO STRUCTURE
SCALE: 1/4" = 1'-0"

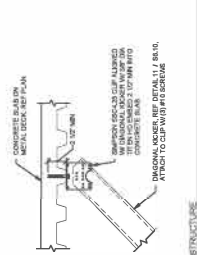

21 SOFFIT KICKER TO STRUCTURE
SCALE: 1/4" = 1'-0"